

# DDR2 SDRAM

## Device Operation & Timing Diagram

## Contents

1. Functional Description
  - 1.1 Simplified State Diagram
  - 1.2 Basic Function & Operation of DDR2 SDRAM
    - 1.2.1 Power up and Initialization
    - 1.2.2 Programming the Mode and Extended Mode Registers
      - 1.2.2.1 DDR2 SDRAM Mode Register (MR)
      - 1.2.2.2 DDR2 SDRAM Extended Mode Register
      - 1.2.2.3 Off-Chip Driver(OCD) Impedance Adjustment
      - 1.2.2.4 ODT(On Die Termination)
    - 1.3 Bank Activate Command
    - 1.4 Read and Write Command
      - 1.4.1 Posted  $\overline{\text{CAS}}$
      - 1.4.2 Burst Mode Operation
      - 1.4.3 Burst Read Command
      - 1.4.4 Burst Write Operation
      - 1.4.5 Write Data Mask
    - 1.5 Precharge Operation
    - 1.6 Auto Precharge Operation
    - 1.7 Refresh Commands
      - 1.7.1 Auto Refresh Command
      - 1.7.2 Self Refresh Command
    - 1.8 Power Down
    - 1.9 Asynchronous CKE LOW Event
    - 1.10 No Operation Command
    - 1.11 Deselect Command
  2. Truth Tables
    - 2.1 Command Truth Table
    - 2.2 Clock Enable(CKE) Truth Table for Synchronous Transistors
    - 2.3 Data Mask Truth Table
  3. Maximum DC Ratings
    - 3.1 Absolute Maximum DC Ratings
    - 3.2 Operating Temperature Condition
  4. AC & DC Operating Conditions
    - 4.1 DC Operation Conditions
      - 4.1.1 Recommended DC Operating Conditions(SSTL\_1.8)
      - 4.1.2 ODT DC Electrical Characteristics
    - 4.2 DC & AC Logic Input Levels
      - 4.2.1 Input DC Logic Level
      - 4.2.2 Input AC Logic Level
      - 4.2.3 AC Input Test Conditions
      - 4.2.4 Differential Input AC Logic Level
      - 4.2.5 Differential AC output parameters
      - 4.2.6 Overshoot / Undershoot Specification
    - 4.3 Output Buffer Levels
      - 4.3.1 Output AC Test Conditions
      - 4.3.2 Output DC Current Drive
      - 4.3.3 OCD default characteristics
    - 4.4 Default Output V-I Characteristics
      - 4.4.1 Full Strength Default Pulldown Driver Characteristics

## 1. Functional Description

### 1.1 Simplified State Diagram

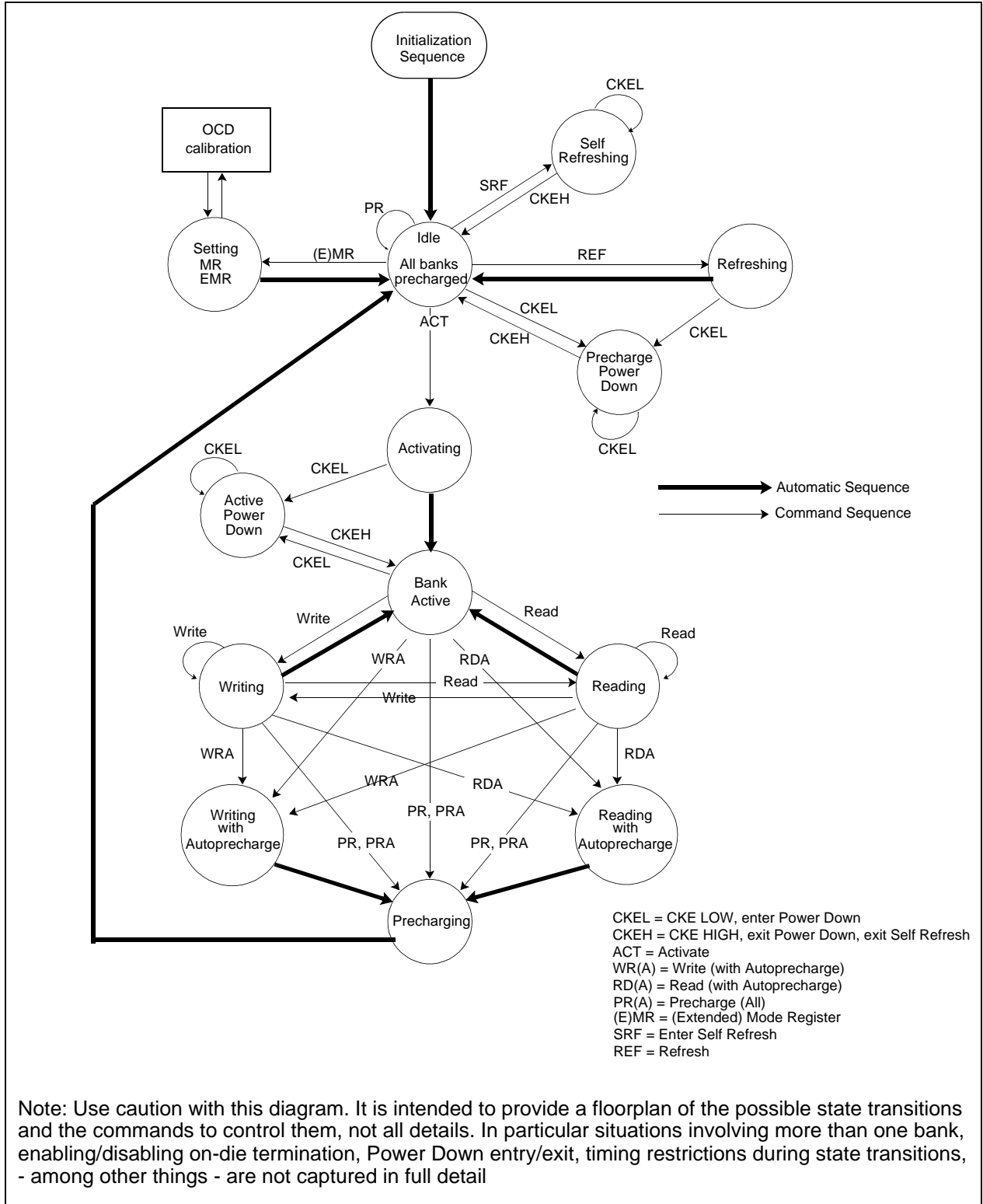


Figure 1. DDR2 SDRAM simplified state diagram

## 1.2 Basic Function & Operation of DDR2 SDRAM

Read and write accesses to the DDR2 SDRAM are burst oriented; accesses start at a selected location and continue for a burst length of four or eight in a programmed sequence. Accesses begin with the registration of an Active command, which is then followed by a Read or Write command. The address bits registered coincident with the active command are used to select the bank and row to be accessed (BA0-BA2 select the bank; A0-A15 select the row). The address bits registered coincident with the Read or Write command are used to select the starting column location for the burst access and to determine if the auto precharge command is to be issued.

Prior to normal operation, the DDR2 SDRAM must be initialized. The following sections provide detailed information covering device initialization, register definition, command descriptions and device operation.

### 1.2.1 Power up and Initialization

DDR2 SDRAMs must be powered up and initialized in a predefined manner. Operational procedures other than those specified may result in undefined operation.

#### Power-up and Initialization Sequence

The following sequence is required for POWER UP and Initialization.

1. Apply power and attempt to maintain  $CKE < 0.2 \cdot VDDQ$  and  $ODT^{*1}$  at a LOW state (all other inputs may be undefined.)
  - VDD, VDDL and VDDQ are driven from a single power converter output, AND
  - VTT is limited to 0.95 V max, AND
  - Vref tracks  $VDDQ/2$ .

or

  - Apply VDD before or at the same time as VDDL.
  - Apply VDDL before or at the same time as VDDQ.
  - Apply VDDQ before or at the same time as VTT & Vref.

at least one of these two sets of conditions must be met.
2. Start clock and maintain stable condition.
3. For the minimum of 200 us after stable power and clock(CK,  $\overline{CK}$ ), then apply NOP or deselect & take CKE HIGH.
4. Wait minimum of 400ns then issue precharge all command. NOP or deselect applied during 400ns period.
5. Issue EMRS command to EMR(2). (To issue EMRS command to EMR(2), provide "LOW" to BA0 and BA2, "HIGH" to BA1.)<sup>\*2</sup>
6. Issue EMRS command to EMR(3). (To issue EMRS command to EMR(3), provide "LOW" to BA2, "HIGH" to BA0 and BA1.)<sup>\*2</sup>
7. Issue EMR to enable DLL. (To issue "DLL Enable" command, provide "LOW" to A0, "HIGH" to BA0 and "LOW" to BA1-2 and A13~A15. And A9=A8=A7=LOW must be sued when issuing this command)
8. Issue a Mode Register set command for "DLL reset".  
(To issue DLL reset command, provide "HIGH" to A8 and "LOW" to BA0-2, and A13~15.)
9. Issue precharge all command.
10. Issue 2 or more auto-refresh commands.
11. Issue a mode register command with LOW to A8 to initialize device operation. (i.e. to program operating parameters without resetting the DLL.)
12. At least 200 clocks after step 8, execute OCD Calibration ( Off Chip Driver impedance adjustment ).

If OCD calibration is not used, EMR OCD Default command (A9=A8=A7=1) followed by EMR OCD Calibration Mode Exit command (A9=A8=A7=0) must be issued with other operating parameters of EMR.

13. The DDR2 SDRAM is now ready for normal operation.

- \*1) To guarantee ODT off, VREF must be valid and a LOW level must be applied to the ODT pin.
- \*2) Sequence 5 and 6 may be performed between 8 and 9.

## Initialization Sequence after Power Up

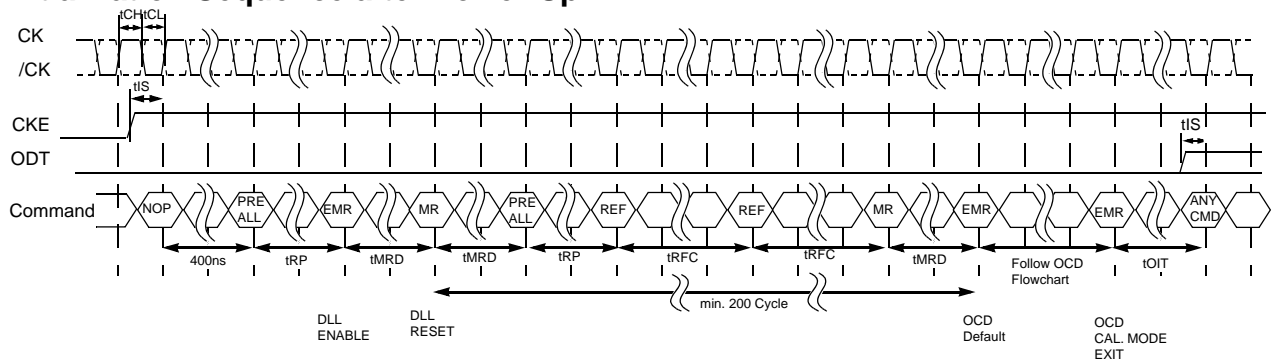


Figure 2. Initialization sequence after power-up

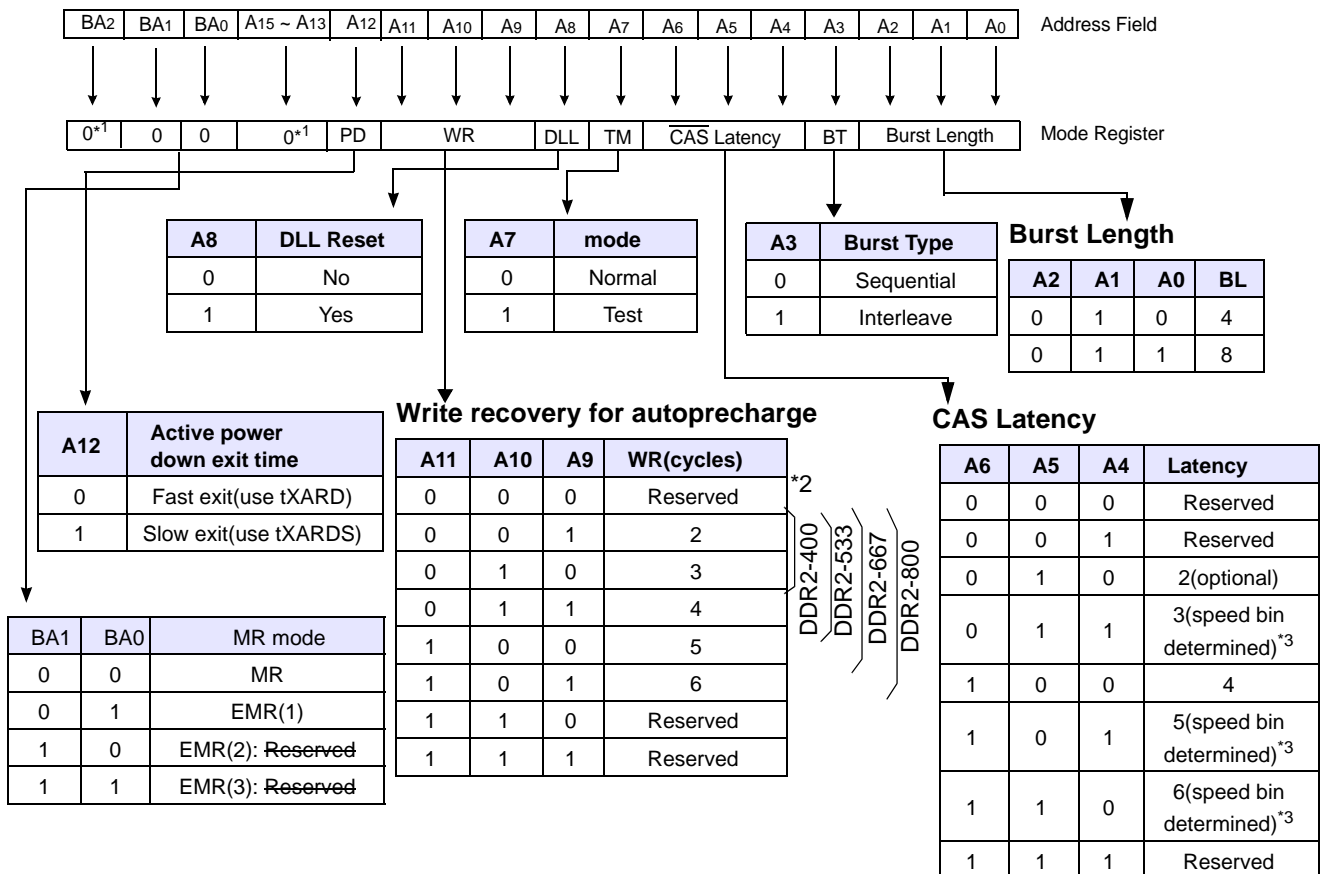
## 1.2.2 Programming the Mode and Extended Mode Registers

For application flexibility, burst length, burst type,  $\overline{\text{CAS}}$  latency, DLL reset function, write recovery time(WR) are user defined variables and must be programmed with a Mode Register Set(MRS) command. Additionally, DLL disable function, driver impedance, additive CAS latency, ODT(On Die Termination), single-ended strobe, and OCD(off chip driver impedance adjustment) are also user defined variables and must be programmed with an Extended Mode Register Set (EMRS) command. Contents of the Mode Register(MR) or Extended Mode Registers(EMR(#)) can be altered by re-executing the MRS and EMRS Commands. Even if the user chooses to modify only a subset of the MR or EMR(#) variables, all variables within the addressed register must be redefined when the MRS or EMRS commands are issued.

MR, EMR and Reset DLL do not affect array contents, which means reinitialization including those can be executed any time after power-up without affecting array contents.

## 1.2.2.1 DDR2 SDRAM Mode Register (MR)

The mode register stores the data for controlling the various operating modes of DDR2 SDRAM. It controls CAS latency, burst length, burst sequence, test mode, DLL reset, WR and various vendor specific options to make DDR2 SDRAM useful for various applications. The default value of the mode register is not defined, therefore the mode register must be programmed during initialization for proper operation. The mode register is written by asserting LOW on CS, RAS, CAS, WE, BA0 and BA1, while controlling the state of address pins A0 ~ A15. The DDR2 SDRAM should be in all bank precharge with CKE already HIGH prior to writing into the mode register. The mode register set command cycle time (tMRD) is required to complete the write operation to the mode register. The mode register contents can be changed using the same command and clock cycle requirements during normal operation as long as all banks are in the precharge state. The mode register is divided into various fields depending on functionality. Burst length is defined by A0 ~ A2 with options of 4 and 8 bit burst lengths. The burst length decodes are compatible with DDR SDRAM. Burst address sequence type is defined by A3, CAS latency is defined by A4 ~ A6. The DDR2 doesn't support half clock latency mode. A7 is used for test mode. A8 is used for DLL reset. A7 must be set to LOW for normal MR operation. Write recovery time WR is defined by A9 ~ A11. Refer to the table for specific codes.



\*1 : BA2 and A13~A15 are reserved for future use and must be programmed to 0 when setting the mode register.  
 \*2: For DDR2-400/533. WR(write recovery for autoprecharge) min is determined by tCK max and WR max is determined by tCK min. WR in clock cycles is calculated by dividing WR (in ns) by tCK (in ns) and rounding up to the next integer (WR[cycles] = WR[ns]/tCK[ns]). For DDR2-667/800. WR min is determined by tCK(avg) max and WR max is determined by tCK(avg) min. (WR[cycles] = WR[ns]/tCK(avg)[ns]) The mode register must be programmed to this value. This is also used with tRP to determine tDAL.  
 \*3 : Speed bin determined. Not required on all speed bins.

Figure 3. DDR2 SDRAM mode register set (MRS)

### 1.2.2.2 DDR2 SDRAM Extended Mode Register

#### EMR(1)

The extended mode register(1) stores the data for enabling or disabling the DLL, output driver strength, additive latency, ODT,  $\overline{\text{DQS}}$  disable, OCD program, RDQS enable. The default value of the extended mode register(1) is not defined, therefore the extended mode register(1) must be programmed during initialization for proper operation. The extended mode register(1) is written by asserting LOW on  $\overline{\text{CS}}$ ,  $\overline{\text{RAS}}$ ,  $\overline{\text{CAS}}$ ,  $\overline{\text{WE}}$ , HIGH on BA0 and LOW on BA1, while controlling the states of address pins A0 ~ A15. The DDR2 SDRAM should be in all bank precharge with CKE already HIGH prior to writing into the extended mode register(1). The mode register set command cycle time (tMRD) must be satisfied to complete the write operation to the extended mode register(1). Mode register contents can be changed using the same command and clock cycle requirements during normal operation as long as all banks are in the precharge state. A0 is used for DLL enable or disable. A1 is used for enabling a half strength output driver. A3~A5 determines the additive latency, A7~A9 are used for OCD control, A10 is used for  $\overline{\text{DQS}}$  disable and A11 is used for RDQS enable. A2 and A6 are used for ODT setting.

#### DLL Enable/Disable

The DLL must be enabled for normal operation. DLL enable is required during power up initialization, and upon returning to normal operation after having the DLL disabled. The DLL is automatically disabled when entering self refresh operation and is automatically re-enabled upon exit of self refresh operation. Any time the DLL is enabled (and subsequently reset), 200 clock cycles must occur before a Read command can be issued to allow time for the internal clock to be synchronized with the external clock. Failing to wait for synchronization to occur may result in a violation of the tAC or tDQSCK parameters.

## EMR(1) Programming:

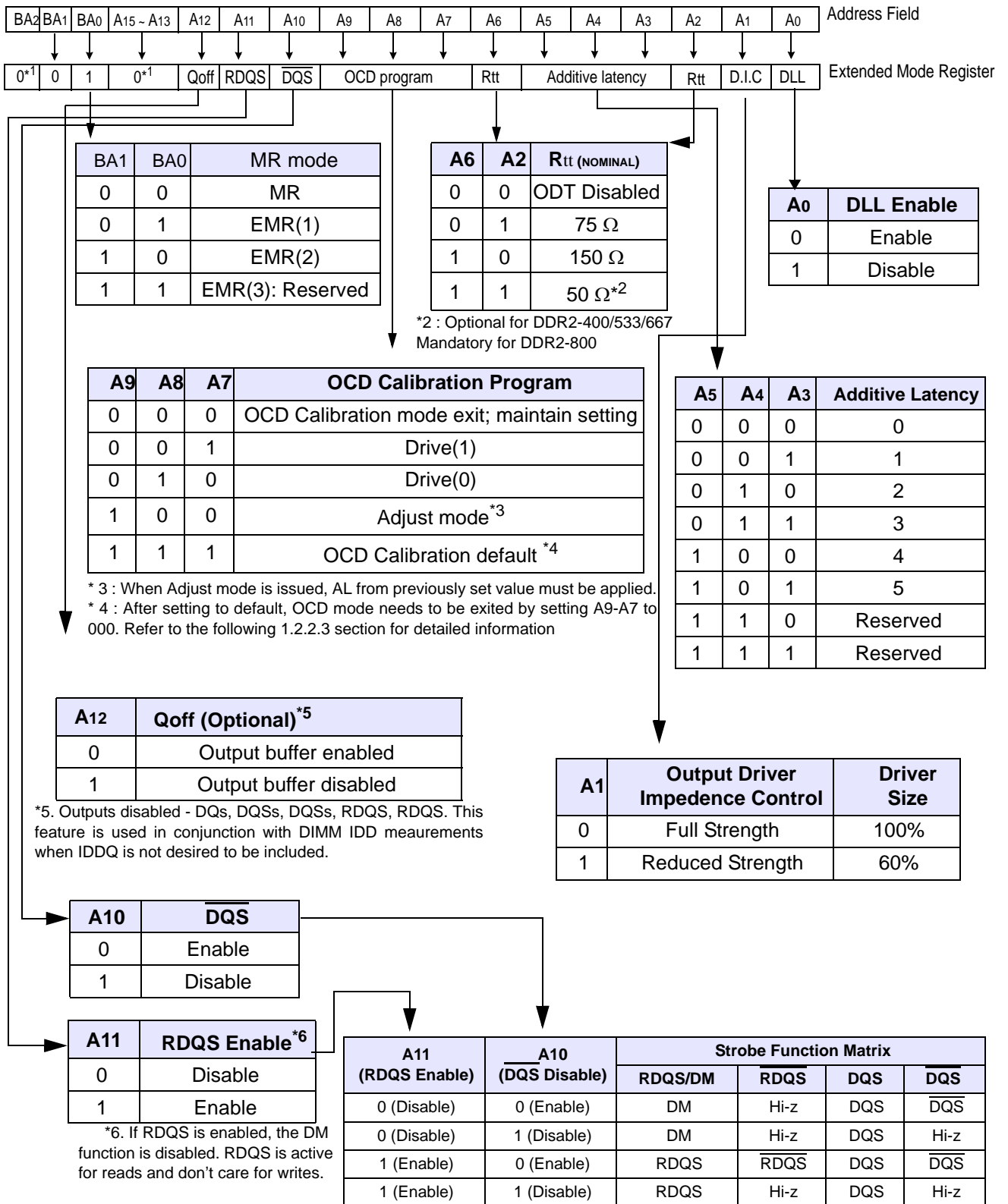
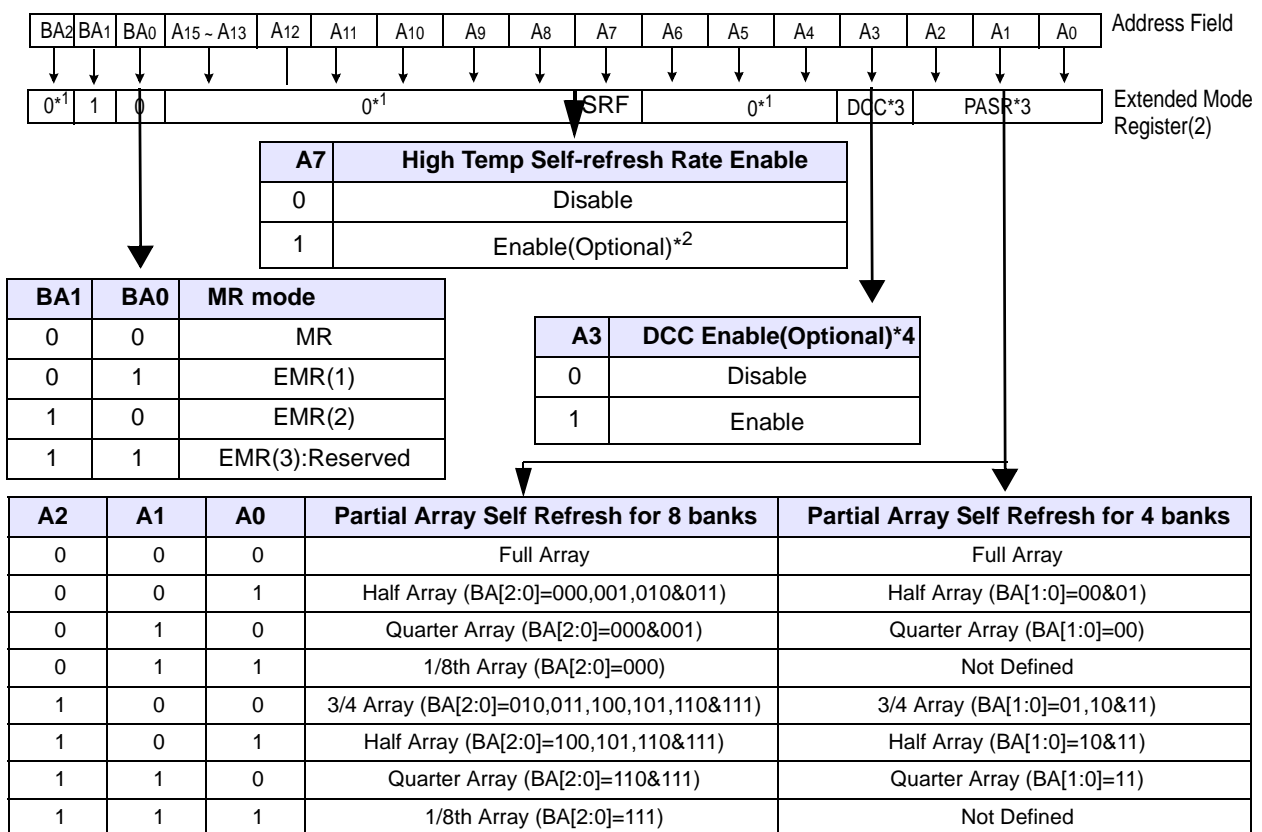


Figure 4. EMR(1) programming

## EMR(2)

The extended mode register(2) controls refresh related features. The default value of the extended mode register(2) is not defined, therefore the extended mode register(2) must be programmed during initialization for proper operation. The extended mode register(2) is written by asserting LOW on /CS,/RAS,/CAS,/WE, HIGH on BA1 and LOW on BA0, while controlling the states of address pins A0~A15. The DDR2 SDRAM should be in all bank precharge with CKE already HIGH prior to writing into the extended mode register(2). The mode register set command cycle time(tMRD) must be satisfied to complete the write operation to the extended mode register(2). Mode register contents can be changed using the same command and clock cycle requirements during normal operation as long as all banks are in the precharge state.

### EMR(2) Programming:



\*1 : The rest bits in EMR(2) are reserved for future use and all bits except A7, BA0 and BA1 must be programmed to 0 when setting the mode register during initialization.

\*2 : Currently the periodic Self-Refresh interval is hard coded within the DRAM to a specific value. EMR(2) bit A7 is a migration plan to support higher Self-Refresh entry. However, since this Self-Refresh control function is an option and to be phased-in by manufacturer individually, checking on the DRAM parts for function availability is necessary. For more details, please refer to "Operating Temperature Condition" section at "Chapter 5. AC & DC operation conditions".

\*3 Optional in DDR2 SDRAM. If PASR (Partial Array Self Refresh) is enabled, data located in areas of the array beyond the specified address range will be lost if self refresh is entered. Data integrity will be maintained if tREF conditions are met and no Self Refresh command is issued. If the PASR feature is not supported, EMR(2)[A0-A2] must be set to 000 when programming EMR(2).

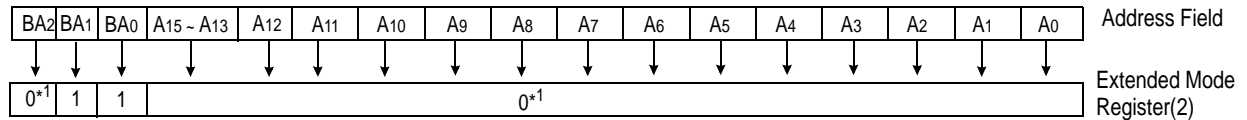
\*4 Optional in DDR2 SDRAM. JEDEC standard DDR2 SDRAM may or may not have DCC (Duty Cycle Corrector) implemented, and in some of the DRAMs implementing DCC, user may be given the controllability of DCC thru EMR(2)[A3] bit. JEDEC standard DDR2 SDRAM users can look at manufacturer's data sheet to check if the DRAM part supports DCC controllability. If Optional DCC Controllability is supported, user may enable or disable the DCC by programming EMR(2)[A3] accordingly. If the controllability feature is not supported, EMR(2)[A3] must be set to 0 when programming EMR(2).

**Figure 5. EMR(2) programming**

## EMR(3)

No function is defined in extended mode register(3). The default value of the extended mode register(3) is not defined, therefore the extended mode register(3) must be programmed during initialization for proper operation.

EMR(3) Programming:



\*1 :All bits in EMR(3) except BA0 and BA1 are reserved for future use and must be programmed to 0 when setting the mode register during initialization.

**Figure 6. EMR(3) programming**

## 1.2.2.3 Off-Chip Driver (OCD) Impedance Adjustment

DDR2 SDRAM supports driver calibration feature and the flow chart below is an example of sequence. Every calibration mode command should be followed by "OCD calibration mode exit" before any other command being issued. All MR should be programmed before entering OCD impedance adjustment and ODT (On Die Termination) should be carefully controlled depending on system environment.

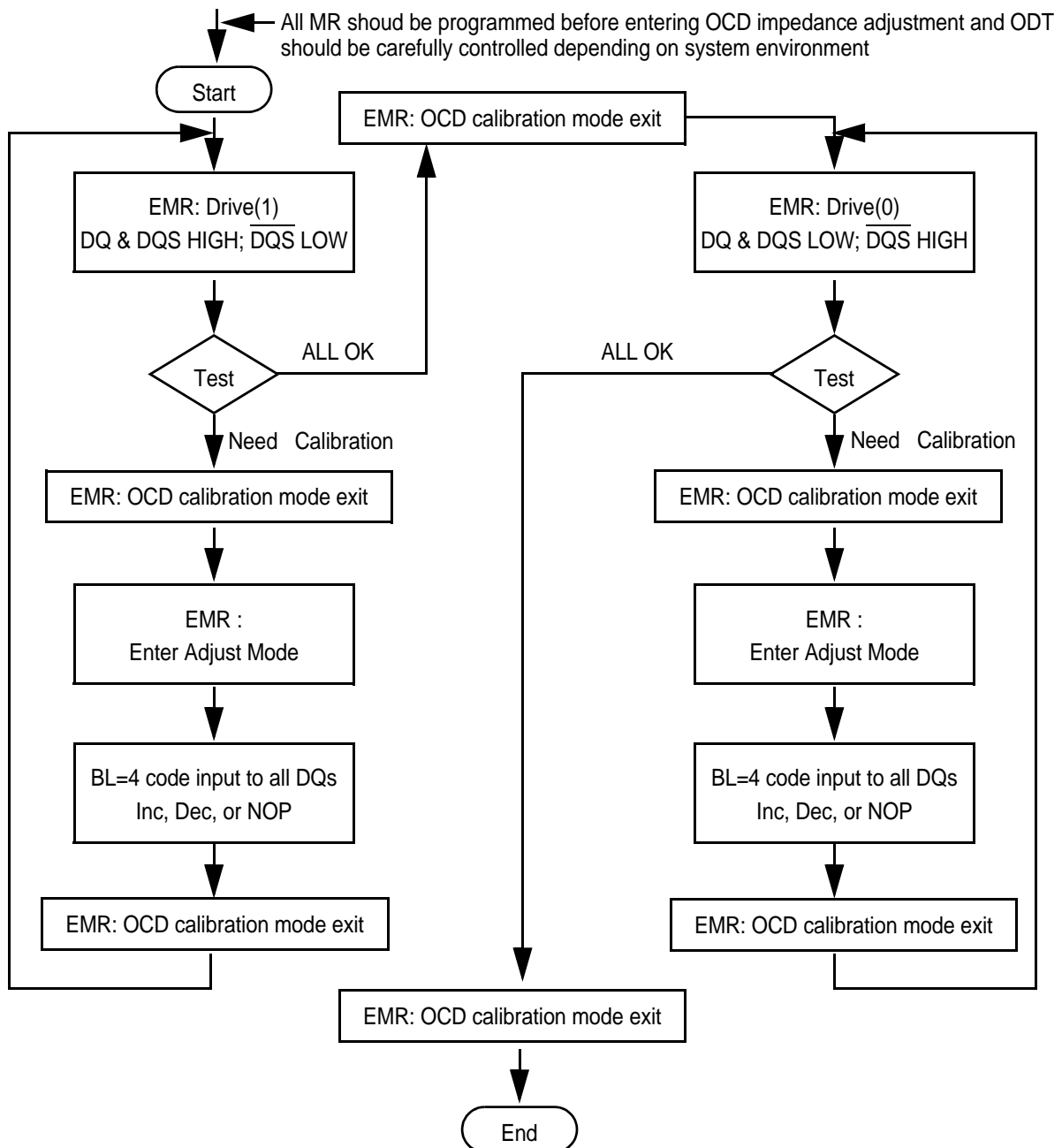


Figure 7. OCD Impedance adjustment

## Extended Mode Register for OCD impedance adjustment

OCD impedance adjustment can be done using the following EMR mode. In drive mode all outputs are driven out by DDR2 SDRAM and drive of RDQS is dependent on EMR bit enabling RDQS operation. In Drive(1) mode, all DQ, DQS (and RDQS) signals are driven HIGH and all  $\overline{DQS}$  signals are driven LOW. In drive(0) mode, all DQ, DQS (and RDQS) signals are driven LOW and all  $\overline{DQS}$  signals are driven HIGH. In adjust mode, BL = 4 of operation code data must be used. In case of OCD calibration default, output driver characteristics have a nominal impedance value of 18  $\Omega$  during nominal temperature and voltage conditions. Output driver characteristics for OCD calibration default are specified in Table x. OCD applies only to normal full strength output drive setting defined by EMR(1) and if half strength is set, OCD default output driver characteristics are not applicable. When OCD calibration adjust mode is used, OCD default output driver characteristics are not applicable. After OCD calibration is completed or driver strength is set to default, subsequent EMR commands not intended to adjust OCD characteristics must specify A9-A7 as '000' in order to maintain the default or calibrated value.

A9	A8	A7	Operation
0	0	0	OCD calibration mode exit
0	0	1	Drive(1) DQ, DQS, (RDQS) HIGH and $\overline{DQS}$ LOW
0	1	0	Drive(0) DQ, DQS, (RDQS) LOW and $\overline{DQS}$ HIGH
1	0	0	Adjust mode
1	1	1	OCD calibration default

**Table 1. OCD drive mode program  
OCD impedance adjust**

To adjust output driver impedance, controllers must issue the ADJUST EMR command along with a 4bit burst code to DDR2 SDRAM as in table X. For this operation, Burst Length has to be set to BL = 4 via MR command before activating OCD and controllers must drive this burst code to all DQs at the same time. DT0 in table X means all DQ bits at bit time 0, DT1 at bit time 1, and so forth. The driver output impedance is adjusted for all DDR2 SDRAM DQs simultaneously and after OCD calibration, all DQs of a given DDR2 SDRAM will be adjusted to the same driver strength setting. The maximum step count for adjustment is 16 and when the limit is reached, further increment or decrement code has no effect. The default setting may be any step within the 16 step range. When Adjust mode command is issued, AL from previously set value must be applied

4bit burst code inputs to all DQs				Operation	
DT0	DT1	DT2	DT3	Pull-up driver strength	Pull-down driver strength
0	0	0	0	NOP (No operation)	NOP (No operation)
0	0	0	1	Increase by 1 step	NOP
0	0	1	0	Decrease by 1 step	NOP
0	1	0	0	NOP	Increase by 1 step
1	0	0	0	NOP	Decrease by 1 step
0	1	0	1	Increase by 1 step	Increase by 1 step
0	1	1	0	Decrease by 1 step	Increase by 1 step
1	0	0	1	Increase by 1 step	Decrease by 1 step
1	0	1	0	Decrease by 1 step	Decrease by 1 step
Other Combinations				Reserved	

**Table 2 : OCD adjust mode program**

For proper operation of adjust mode,  $WL = RL - 1 = AL + CL - 1$  clocks and  $tDS/tDH$  should be met as the following timing diagram. For input data pattern for adjustment,  $DT0 - DT3$  is a fixed order and "not affected by MR addressing mode (ie. sequential or interleave).

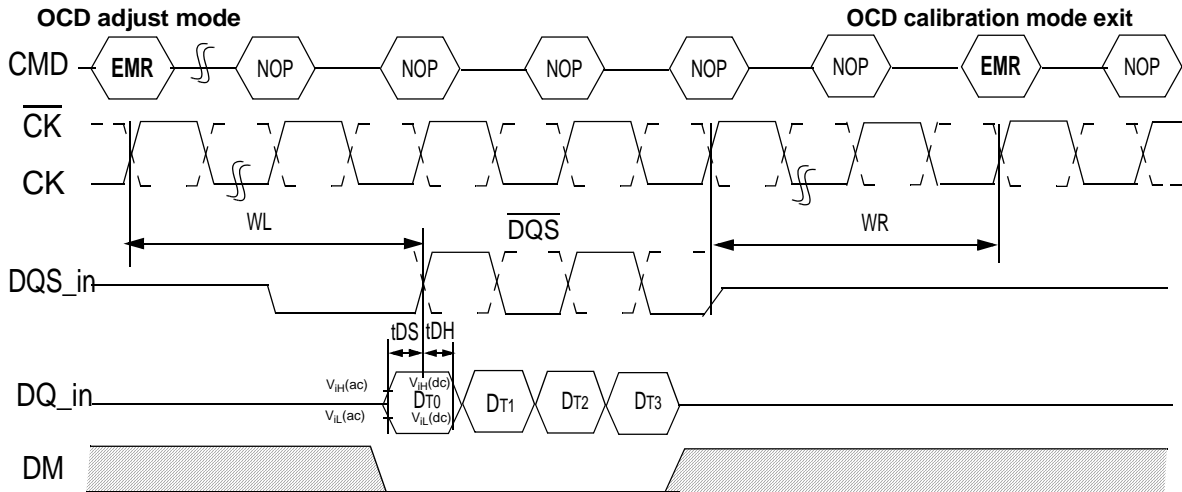


Figure 8. OCD adjust mode

## Drive Mode

Drive mode, both Drive(1) and Drive(0), is used for controllers to measure DDR2 SDRAM Driver impedance. In this mode, all outputs are driven out  $tOIT$  after "enter drive mode" command and all output drivers are turned-off  $tOIT$  after "OCD calibration mode exit" command as the following timing diagram

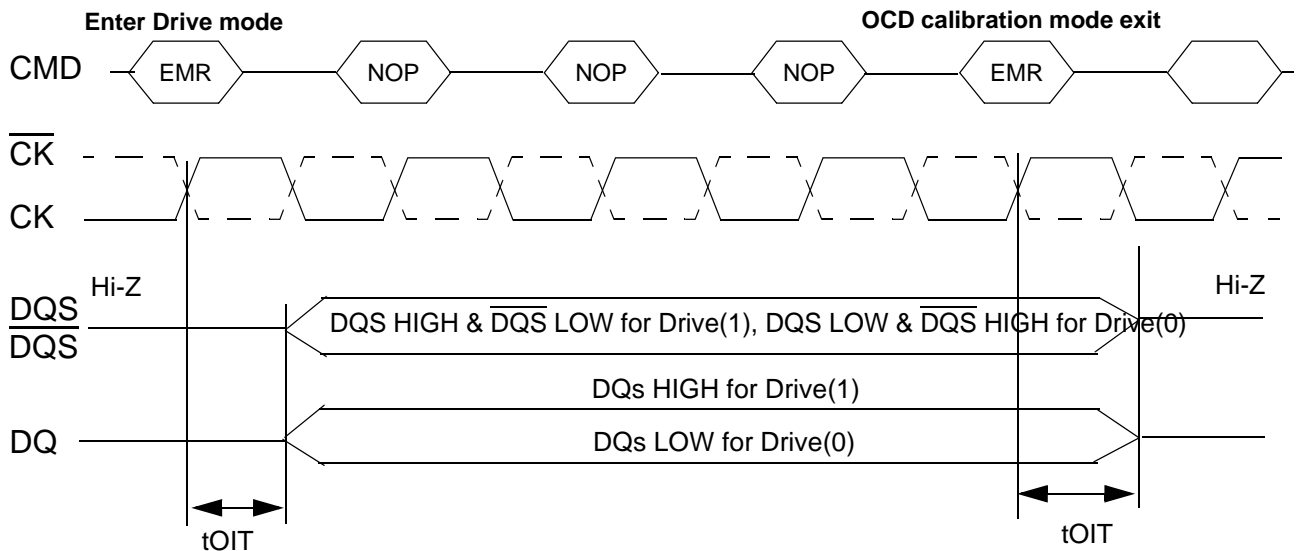


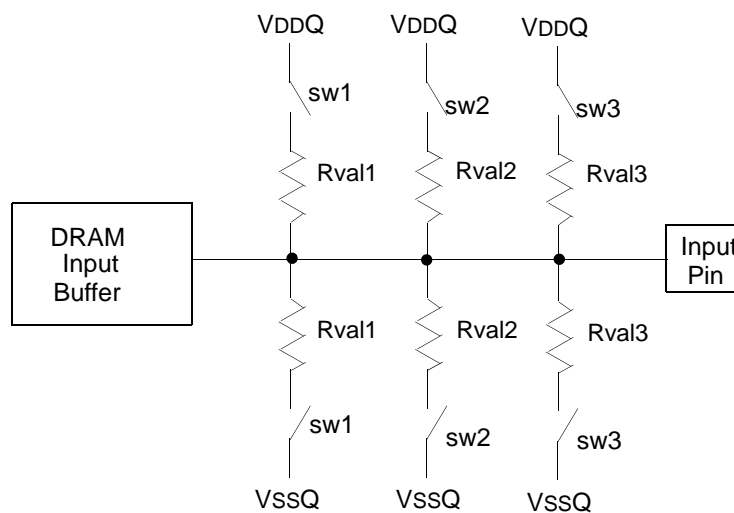
Figure 9. OCD drive mode

## 1.2.2.4 ODT (On Die Termination)

On Die Termination (ODT) is a feature that allows a DRAM to turn on/off termination resistance for each DQ, DQS/DQS, RDQS/RDQS, and DM signal for x4x8 configurations via the ODT control pin. For x16 configuration ODT is applied to each DQ, UDQS/UDQS, LDQS/LDQS, UDM, and LDM signal via the ODT control pin. The ODT feature is designed to improve signal integrity of the memory channel by allowing the DRAM controller to independently turn on/off termination resistance for any or all DRAM devices.

The ODT function is supported for ACTIVE and STANDBY modes. ODT is turned off and not supported in SELF REFRESH mode.

### FUNCTIONAL REPRESENTATION OF ODT



Switch (sw1 , sw2 , sw3) is enabled by ODT pin.  
 Selection among sw1, sw2 and sw3 is determined by "Rtt (nominal)" in EMR  
 Termination included on all DQs, DM, DQS, DQS, RDQS, and RDQS pins.

**Figure 10. Functional representation of ODT**

## ODT timing for active/standby mode

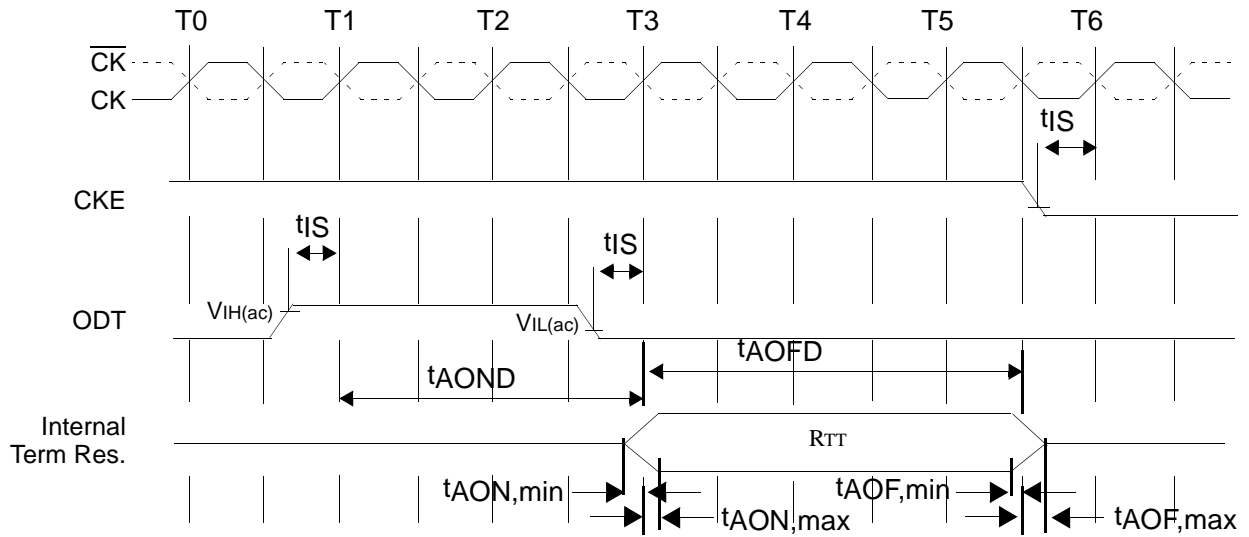


Figure 11. ODT timing for active/standby mode

## ODT timing for powerdown mode

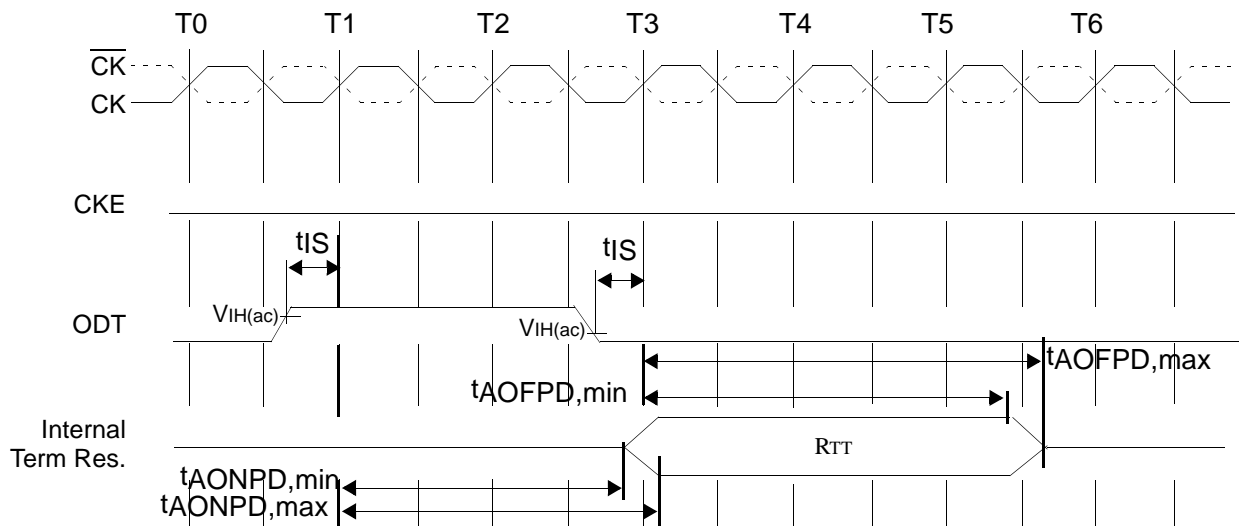


Figure 12. ODT timing for powerdown mode

## ODT timing mode switch at entering power down mode

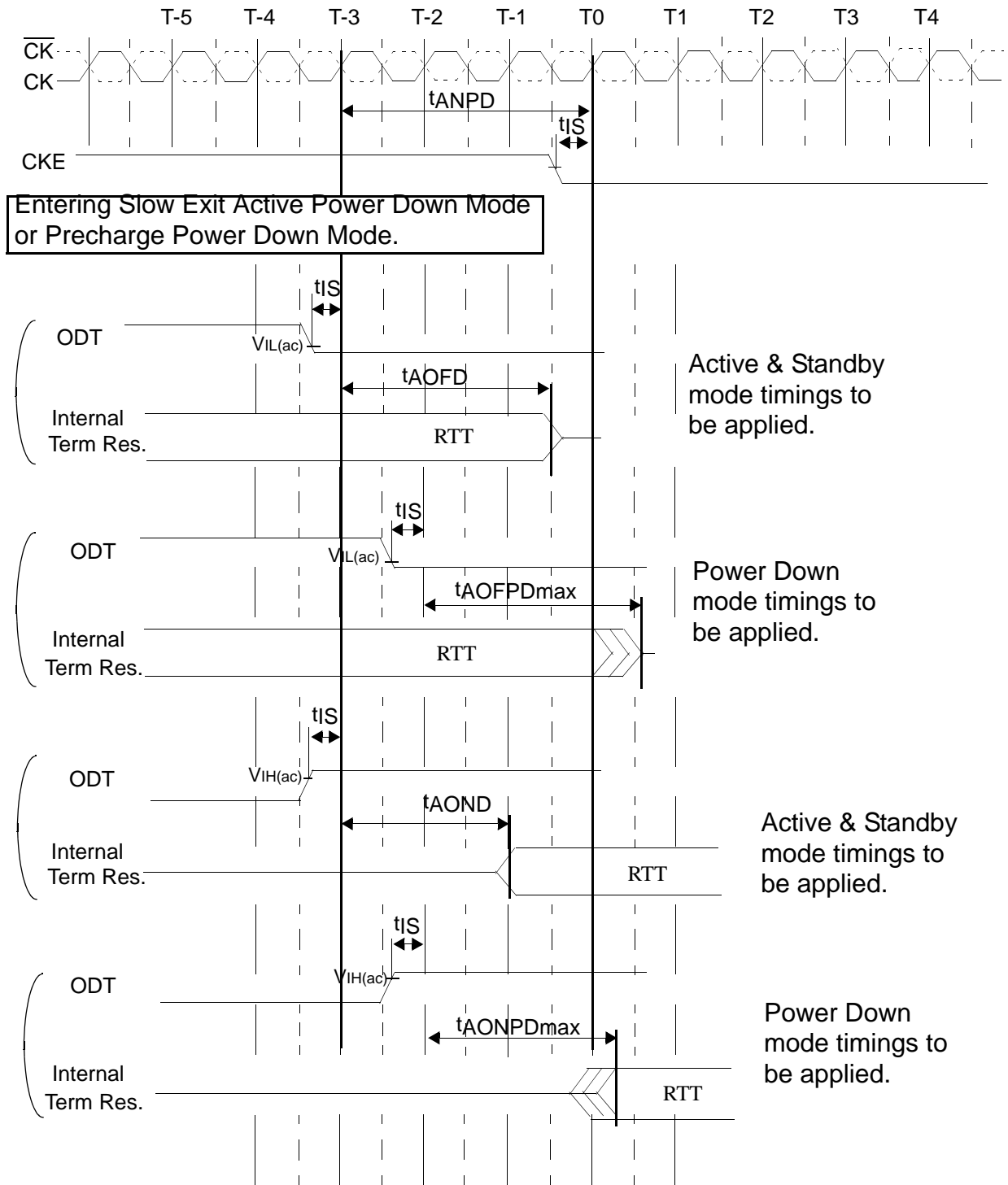


Figure 13. ODT timing mode switch at entering power-down mode

## ODT timing mode switch at exiting power down mode

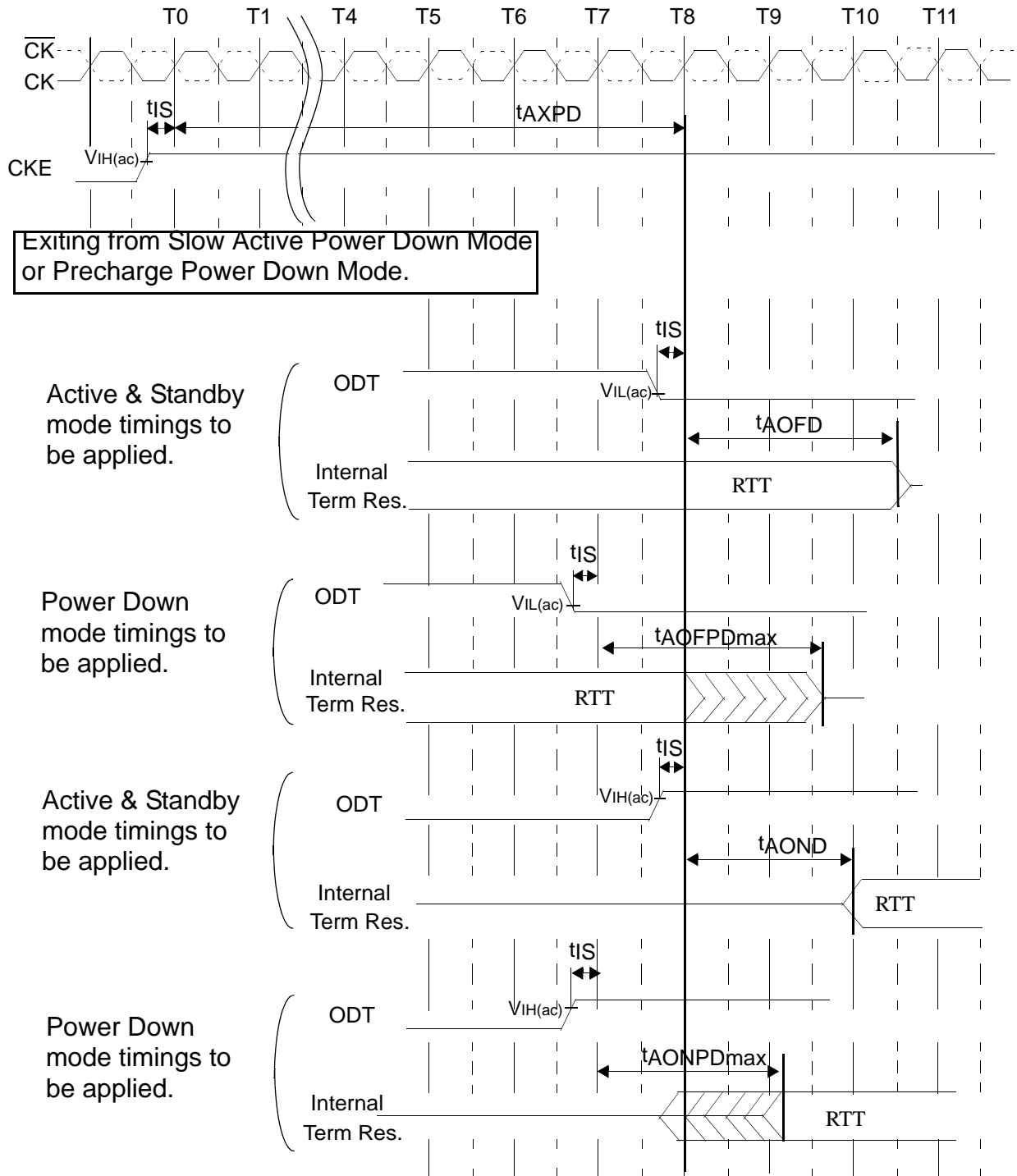


Figure 14. ODT timing mode switch at exiting power-down mode

## 1.3 Bank Activate Command

The Bank Activate command is issued by holding  $\overline{\text{CAS}}$  and  $\overline{\text{WE}}$  HIGH with  $\overline{\text{CS}}$  and  $\overline{\text{RAS}}$  LOW at the rising edge of the clock. The bank addresses BA0 ~ BA2 are used to select the desired bank. The row address A0 through A15 is used to determine which row to activate in the selected bank. The Bank Activate command must be applied before any Read or Write operation can be executed. Immediately after the bank active command, the DDR2 SDRAM can accept a read or write command on the following clock cycle. If a R/W command is issued to a bank that has not satisfied the  $t_{\text{RCDmin}}$  specification, then additive latency must be programmed into the device to delay when the R/W command is internally issued to the device. The additive latency value must be chosen to assure  $t_{\text{RCDmin}}$  is satisfied. Additive latencies of 0, 1, 2, 3 and 4 are supported. Once a bank has been activated it must be precharged before another Bank Activate command can be applied to the same bank. The bank active and precharge times are defined as  $t_{\text{RAS}}$  and  $t_{\text{RP}}$ , respectively. The minimum time interval between successive Bank Activate commands to the same bank is determined by the RAS cycle time of the device ( $t_{\text{RC}}$ ). The minimum time interval between Bank Activate commands is  $t_{\text{RRD}}$ .

In order to ensure that 8 bank devices do not exceed the instantaneous current supplying capability of 4 bank devices, certain restrictions on operation of the 8 bank devices must be observed. There are two rules. One for restricting the number of sequential ACT commands that can be issued and another for allowing more time for RAS precharge for a Precharge All command. The rules are as follows:

\* 8 bank device Sequential Bank Activation Restriction: No more than 4 banks may be activated in a rolling  $t_{\text{FAW}}$  window. Converting to clocks is done by dividing  $t_{\text{FAW}}[\text{ns}]$  by  $t_{\text{CK}}[\text{ns}]$  or  $t_{\text{CK}}(\text{avg})[\text{ns}]$ , depending on the speed bin, and rounding up to next integer value. As an example of the rolling window, if  $(t_{\text{FAW}}/t_{\text{CK}})$  or  $(t_{\text{FAW}}/t_{\text{CK}}(\text{avg}))$  rounds up to 10 clocks, and an activate command is issued in clock N, no more than three further activate commands may be issued at or between clock N+1 through N+9.

\* 8 bank device Precharge All Allowance :  $t_{\text{RP}}$  for a Precharge All command for an 8 Bank device will equal to  $t_{\text{RP}}+1*t_{\text{CK}}$  or  $t_{\text{RP}} + 1*n_{\text{CK}}$ , depending on the speed bin, where  $t_{\text{RP}}=t_{\text{RP}}/t_{\text{CK}}(\text{avg})$  rounded up to the next interger, where  $t_{\text{RP}}$  is the value for a single bank pre-charge.

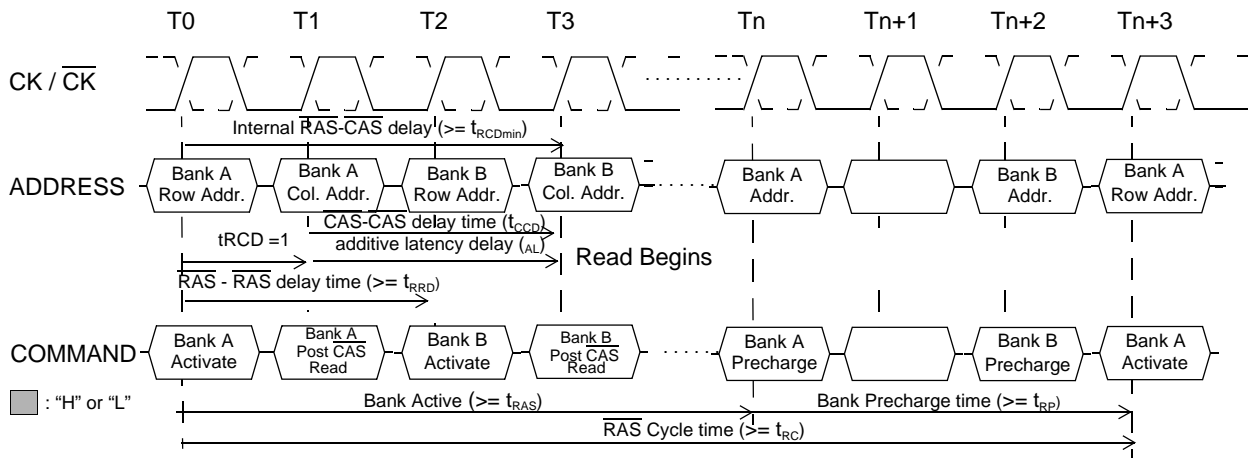


Figure 15. Bank active command cycle:  $t_{\text{RCD}}=3$ ,  $AL=2$ ,  $t_{\text{RP}}=3$ ,  $t_{\text{RRD}}=2$ ,  $t_{\text{CCD}}=2$

## 1.4 Read and Write Access Modes

After a bank has been activated, a read or write cycle can be executed. This is accomplished by setting  $\overline{\text{RAS}}$  HIGH,  $\overline{\text{CS}}$  and  $\overline{\text{CAS}}$  LOW at the clock's rising edge.  $\overline{\text{WE}}$  must also be defined at this time to determine whether the access cycle is a read operation ( $\overline{\text{WE}}$  HIGH) or a write operation ( $\overline{\text{WE}}$  LOW).

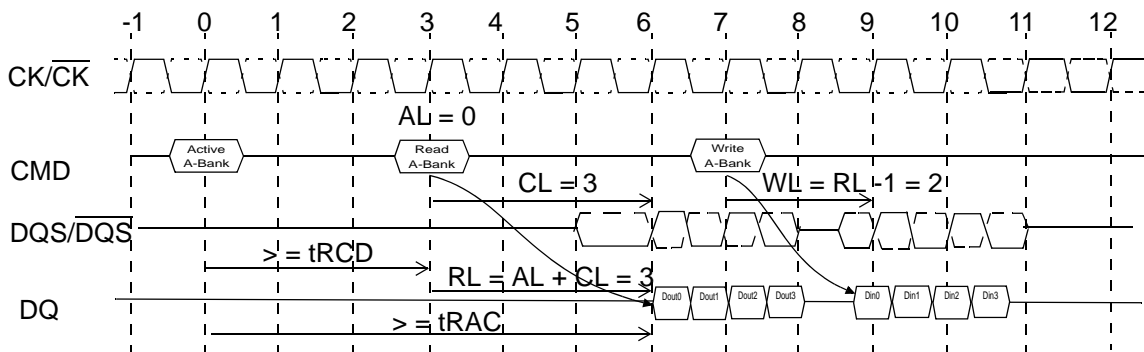
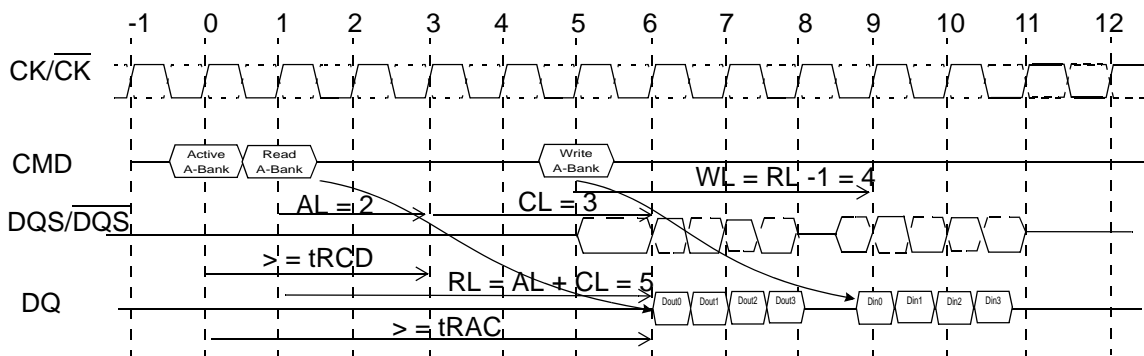
The DDR2 SDRAM provides a fast column access operation. A single Read or Write Command will initiate a serial read or write operation on successive clock cycles. The boundary of the burst cycle is strictly restricted to specific segments of the page length. For example, the 32Mbit x 4 I/O x 4 Bank chip has a page length of 2048 bits (defined by CA0-CA9, CA11). The page length of 2048 is divided into 512 or 256 uniquely addressable boundary segments depending on burst length, 512 for 4 bit burst, 256 for 8 bit burst respectively. A 4-bit or 8 bit burst operation will occur entirely within one of the 512 or 256 groups beginning with the column address supplied to the device during the Read or Write Command (CA0-CA9, CA11). The second, third and fourth access will also occur within this group segment, however, the burst order is a function of the starting address, and the burst sequence.

A new burst access must not interrupt the previous 4 bit burst operation in case of BL = 4 setting. However, in case of BL = 8 setting, two cases of interrupt by a new burst access are allowed, one reads interrupted by a read, the other writes interrupted by a write with 4 bit burst boundary respectively. The minimum  $\overline{\text{CAS}}$  to  $\overline{\text{CAS}}$  delay is defined by tCCD, and is a minimum of 2 clocks for read or write cycles.

## 1.4.1 Posted CAS

Posted CAS operation is supported to make command and data bus efficient for sustainable bandwidths in DDR2 SDRAM. In this operation, the DDR2 SDRAM allows a CAS read or write command to be issued immediately after the RAS bank activate command (or any time during the RAS-CAS-delay time, tRCD, period). The command is held for the time of the Additive Latency (AL) before it is issued inside the device. The Read Latency (RL) is controlled by the sum of AL and the CAS latency (CL). Therefore if a user chooses to issue a R/W command before the tRCDmin, then AL (greater than 0) must be written into the EMR(1). The Write Latency (WL) is always defined as RL - 1 (read latency - 1) where read latency is defined as the sum of additive latency plus CAS latency (RL=AL+CL). Read or Write operations using AL allow seamless bursts (refer to seamless operation timing diagram examples in Read burst and Write burst section)

### Examples of posted CAS operation



## 1.4.2 Burst Mode Operation

Burst mode operation is used to provide a constant flow of data to memory locations (write cycle), or from memory locations (read cycle). The parameters that define how the burst mode will operate are burst sequence and burst length. DDR2 SDRAM supports 4 bit burst and 8 bit burst modes only. For 8 bit burst mode, full interleave address ordering is supported, however, sequential address ordering is nibble based for ease of implementation. The burst type, either sequential or interleaved, is programmable and defined by the address bit 3 (A3) of the MR, which is similar to the DDR SDRAM operation. Seamless burst read or write operations are supported. Unlike DDR devices, interruption of a burst read or write cycle during BL = 4 mode operation is prohibited. However in case of BL = 8 mode, interruption of a burst read or write operation is limited to two cases, reads interrupted by a read, or writes interrupted by a write. Therefore the Burst Stop command is not supported on DDR2 SDRAM devices.

### Burst Length and Sequence

Burst Length	Starting Address (A2 A1 A0)	Sequential Addressing (decimal)	Interleave Addressing (decimal)
4	0 0 0	0, 1, 2, 3	0, 1, 2, 3
	0 0 1	1, 2, 3, 0	1, 0, 3, 2
	0 1 0	2, 3, 0, 1	2, 3, 0, 1
	0 1 1	3, 0, 1, 2	3, 2, 1, 0
8	0 0 0	0, 1, 2, 3, 4, 5, 6, 7	0, 1, 2, 3, 4, 5, 6, 7
	0 0 1	1, 2, 3, 0, 5, 6, 7, 4	1, 0, 3, 2, 5, 4, 7, 6
	0 1 0	2, 3, 0, 1, 6, 7, 4, 5	2, 3, 0, 1, 6, 7, 4, 5
	0 1 1	3, 0, 1, 2, 7, 4, 5, 6	3, 2, 1, 0, 7, 6, 5, 4
	1 0 0	4, 5, 6, 7, 0, 1, 2, 3	4, 5, 6, 7, 0, 1, 2, 3
	1 0 1	5, 6, 7, 4, 1, 2, 3, 0	5, 4, 7, 6, 1, 0, 3, 2
	1 1 0	6, 7, 4, 5, 2, 3, 0, 1	6, 7, 4, 5, 2, 3, 0, 1
	1 1 1	7, 4, 5, 6, 3, 0, 1, 2	7, 6, 5, 4, 3, 2, 1, 0

Note: Page length is a function of I/O organization and column addressing

**Table 3. Burst length and sequence**

## 1.4.3 Burst Read Command

The Burst Read command is initiated by having  $\overline{CS}$  and  $\overline{CAS}$  LOW while holding  $\overline{RAS}$  and  $\overline{WE}$  HIGH at the rising edge of the clock. The address inputs determine the starting column address for the burst. The delay from the start of the command to when the data from the first cell appears on the outputs is equal to the value of the read latency (RL). The data strobe output (DQS) is driven LOW 1 clock cycle before valid data (DQ) is driven onto the data bus. The first bit of the burst is synchronized with the rising edge of the data strobe (DQS). Each subsequent data-out appears on the DQ pin in phase with the DQS signal in a source synchronous manner. The RL is equal to an additive latency (AL) plus CAS latency (CL). The CL is defined by the Mode Register (MR), similar to the existing SDR and DDR SDRAMs. The AL is defined by the Extended Mode Register (1)(EMR(1)).

DDR2 SDRAM pin timings are specified for either single ended mode or differential mode depending on the setting of the EMR(1) "Enable DQS" mode bit; timing advantages of differential mode are realized in system design. The method by which the DDR2 SDRAM pin timings are measured is mode dependent. In single ended mode, timing relationships are measured relative to the rising or falling edges of DQS crossing at VREF. In differential mode, these timing relationships are measured relative to the crosspoint of DQS and its complement,  $\overline{DQS}$ . This distinction in timing methods is guaranteed by design and characterization. Note that when differential data strobe mode is disabled via the EMR, the complementary pin,  $\overline{DQS}$ , must be tied externally to VSS through a 20  $\Omega$  to 10 K $\Omega$  resistor to insure proper operation.

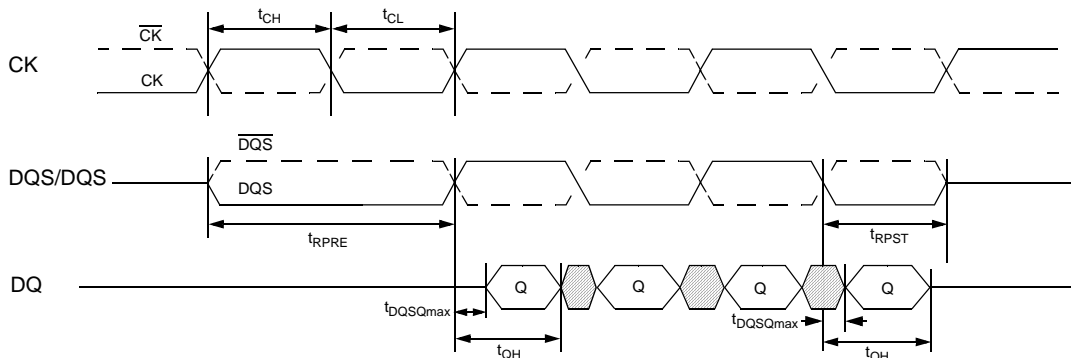


Figure 18. Data output (read) timing

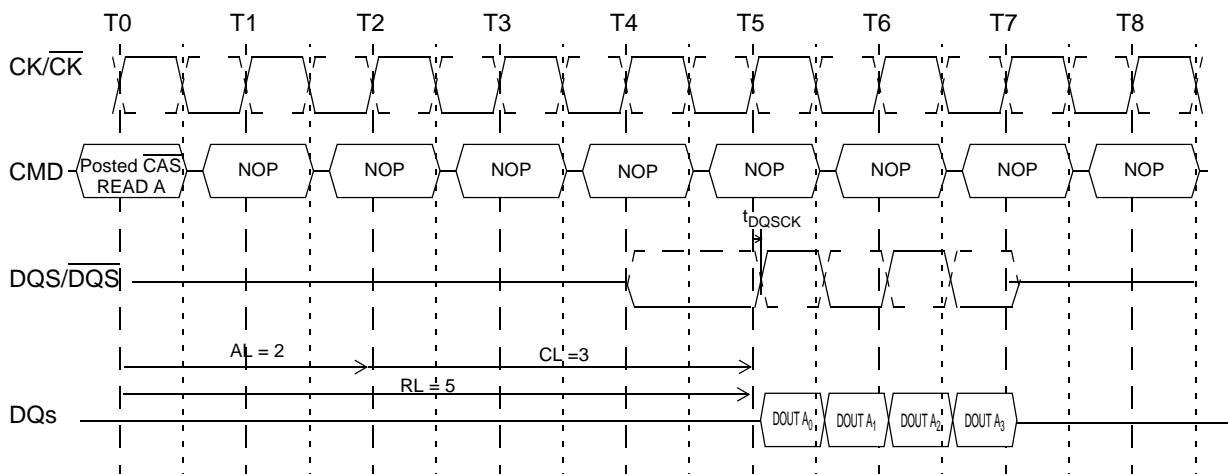
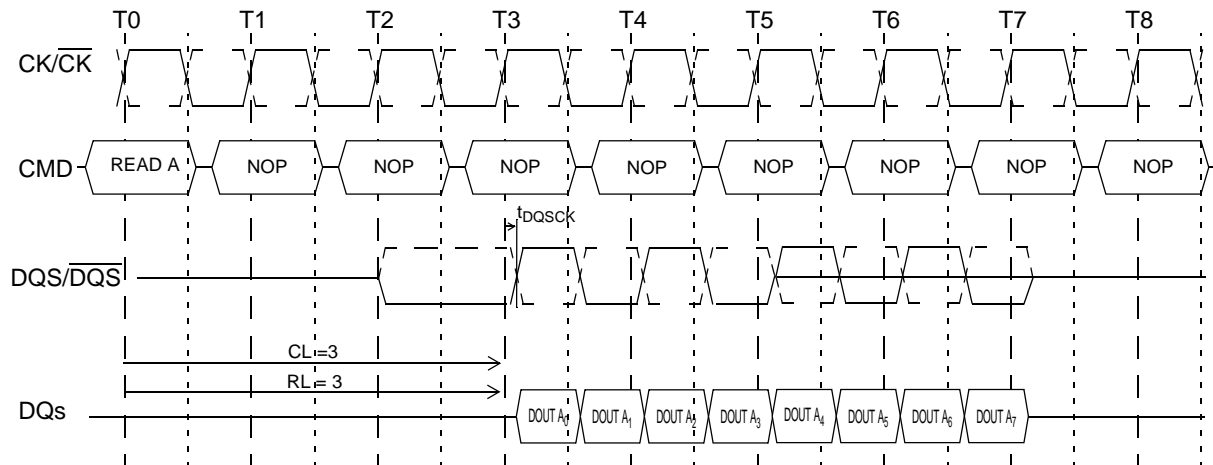
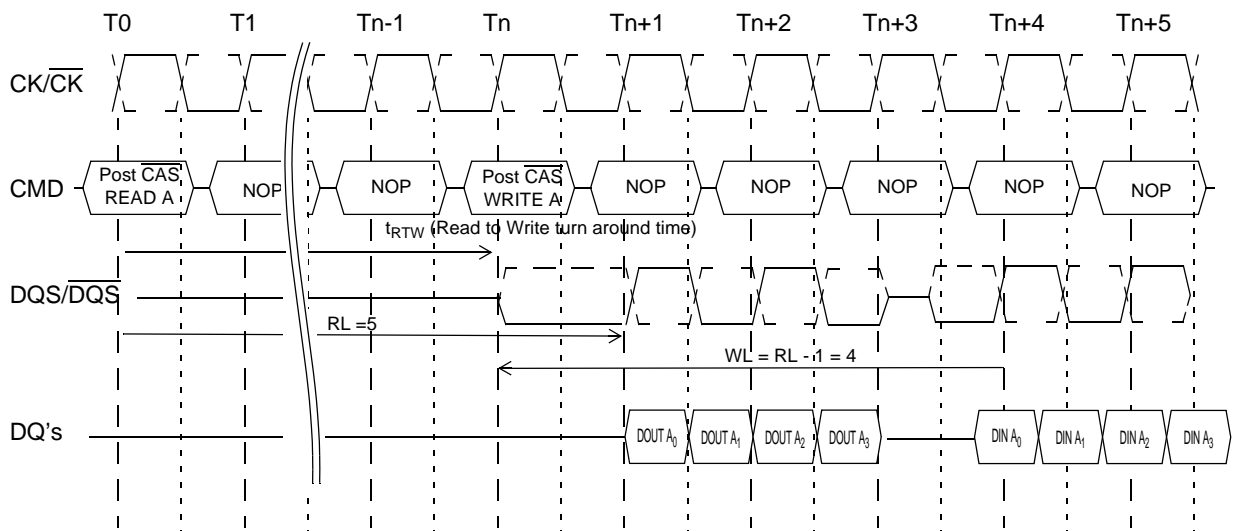


Figure 19. Burst read operation: RL =5 (AL=2, CL=3, BL=4)

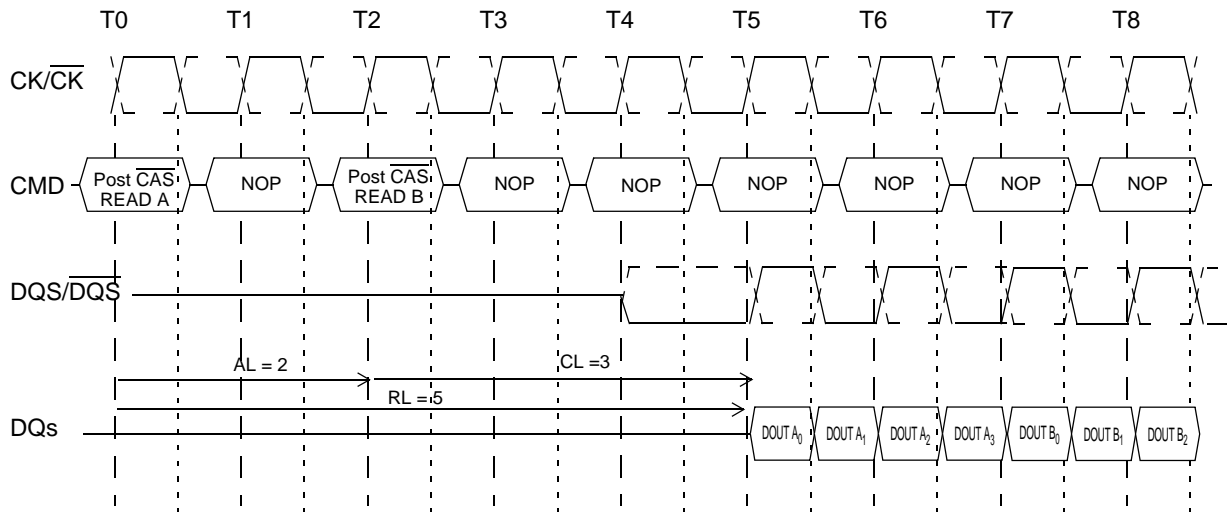


**Figure 20. Burst read operation: RL = 3 (AL=0, CL=3, BL=8)**



**Figure 21. Burst read followed by burst write: RL = 5, WL = (RL-1) = 4, BL = 4**

The minimum time from the burst read command to the burst write command is defined by a read-to-write-turn-around-time, which is 4 clocks in case of BL = 4 operation, 6 clocks in case of BL = 8 operation.

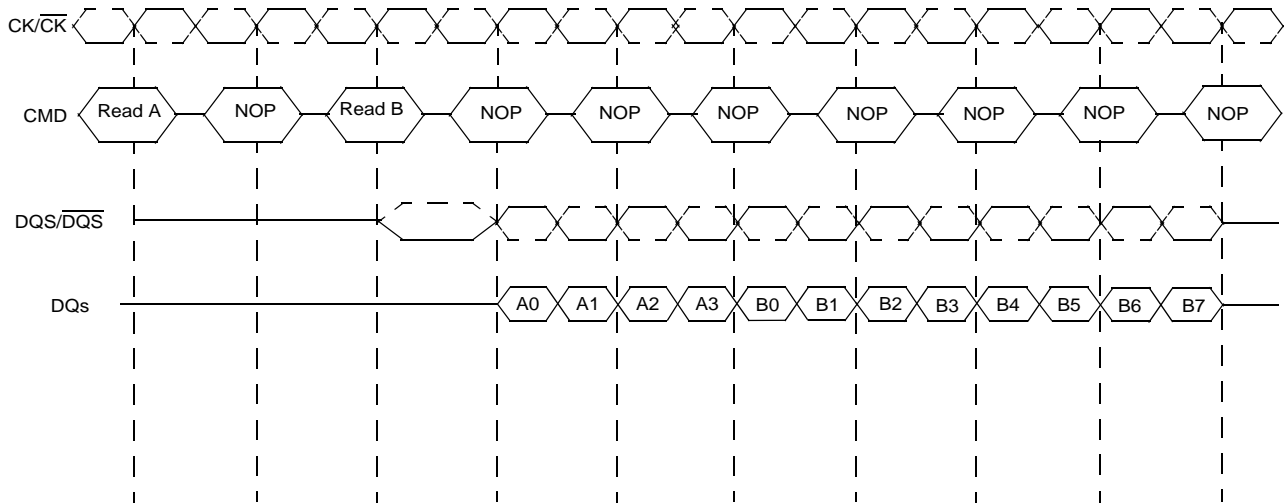


**Figure 22. Seamless burst read operation: RL = 5, AL = 2, and CL = 3, BL = 4**

The seamless burst read operation is supported by enabling a read command at every other clock for BL = 4 operation, and every 4 clock for BL = 8 operation. This operation is allowed regardless of same or different banks as long as the banks are activated.

## Reads interrupted by a read

Burst read can only be interrupted by another read with 4 bit burst boundary. Any other case of read interrupt is not allowed.

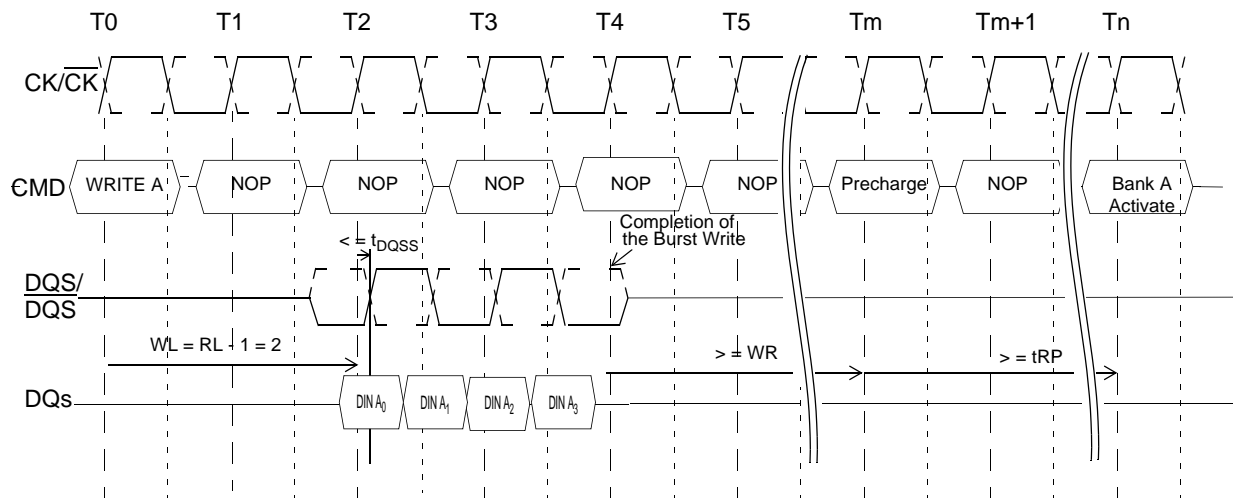


### Note

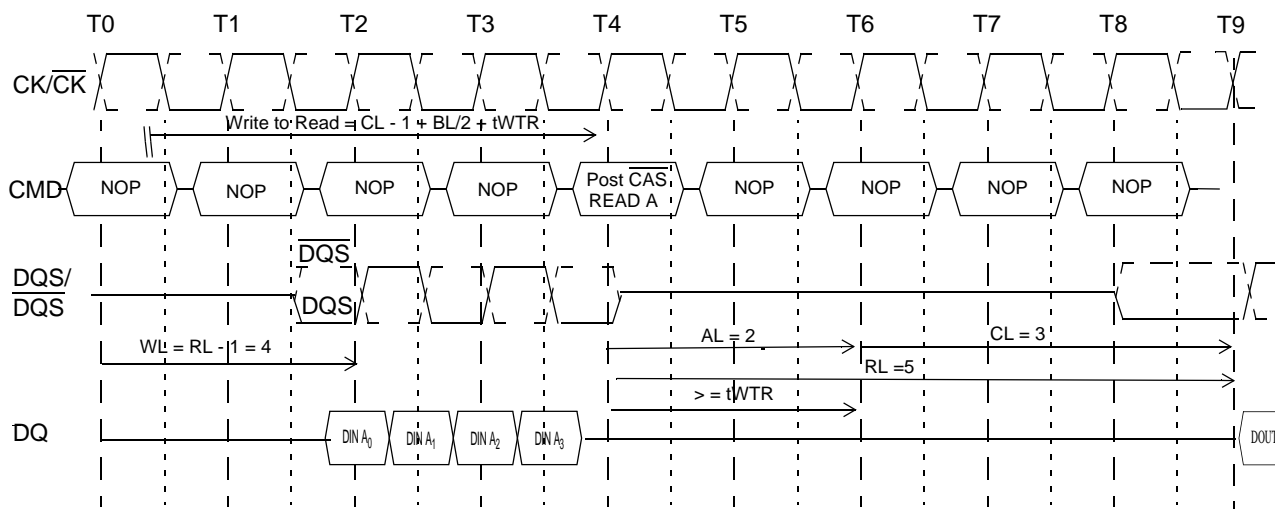
1. Read burst interrupt function is only allowed on burst of 8. Burst interrupt of 4 is prohibited.
2. Read burst of 8 can only be interrupted by another Read command. Read burst interruption by Write command or Precharge command is prohibited.
3. Read burst interrupt must occur exactly two clocks after previous Read command. Any other Read burst interrupt timings are prohibited.
4. Read burst interruption is allowed to any bank inside DRAM.
5. Read burst with Auto Precharge enabled is not allowed to interrupt.
6. Read burst interruption is allowed by another Read with Auto Precharge command.
7. All command timings are referenced to burst length set in the mode register. They are not referenced to actual burst. For example, Minimum Read to Precharge timing is  $AL + BL/2$  where BL is the burst length set in the mode register and not the actual burst (which is shorter because of interrupt).

**Figure 23. Read burst interrupt timing example: (CL=3, AL=0, RL=3, BL=8)**



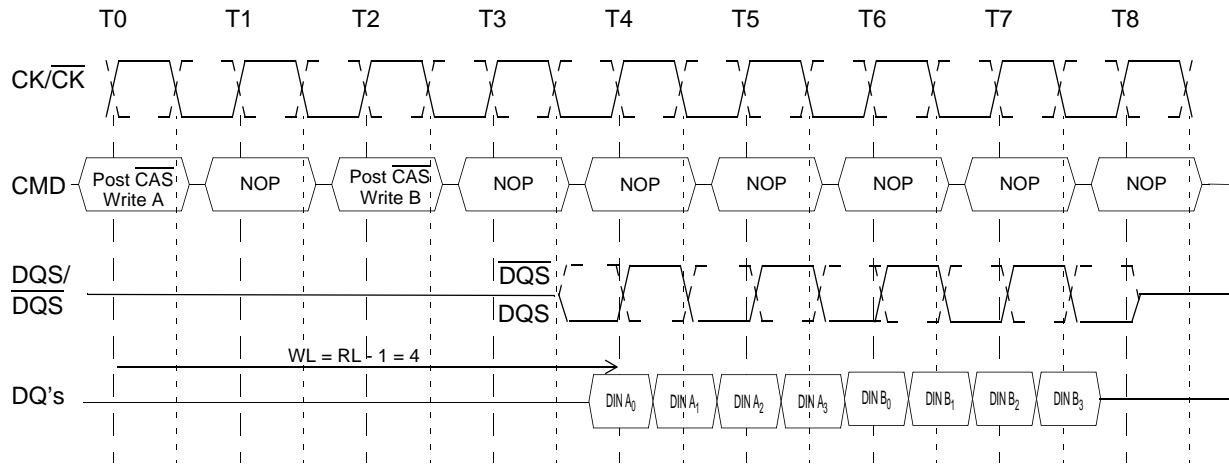


**Figure 26. Burst write operation: RL = 3(AL=0, CL=3), WL = 2, BL = 4**



The minimum number of clock from the burst write command to the burst read command is  $[CL - 1 + BL/2 + tWTR]$ . This  $tWTR$  is not a write recovery time ( $WR$ ) but the time required to transfer the 4bit write data from the input buffer into sense amplifiers in the array.  $tWTR$  is defined in AC spec table of this data sheet.

**Figure 27. Burst write followed by burst read: RL = 5 (AL=2, CL=3), WL = 4,  $tWTR$  = 2, BL = 4**

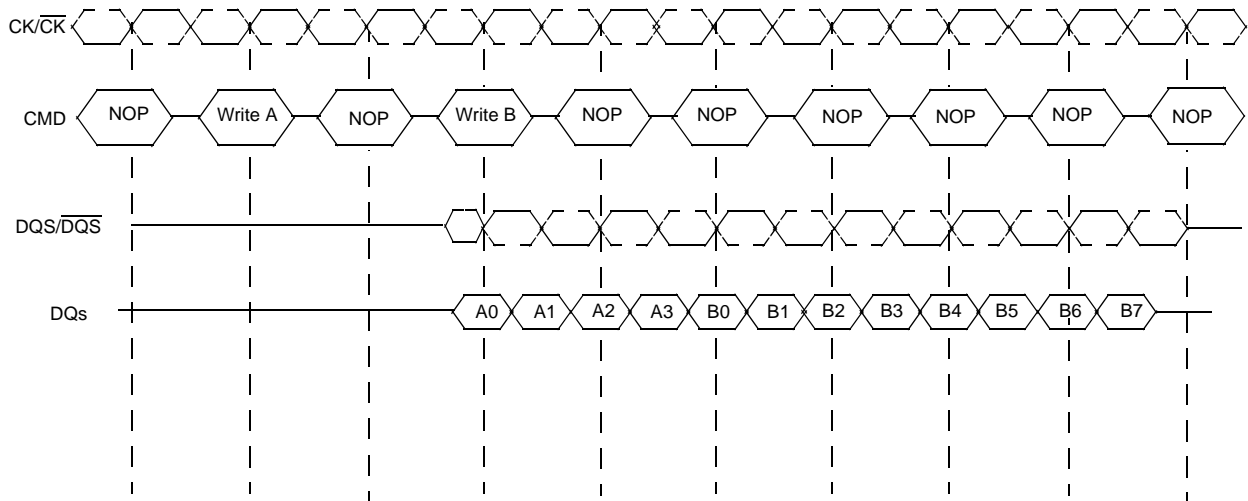


**Figure 28. Seamless Burst Write Operation: RL = 5, WL = 4, BL = 4**

The seamless burst write operation is supported by enabling a write command every other clock for BL = 4 operation, every four clocks for BL = 8 operation. This operation is allowed regardless of same or different banks as long as the banks are activated

## Writes interrupted by a write

Burst write can only be interrupted by another write with 4 bit burst boundary. Any other case of write interrupt is not allowed.



**Notes:**

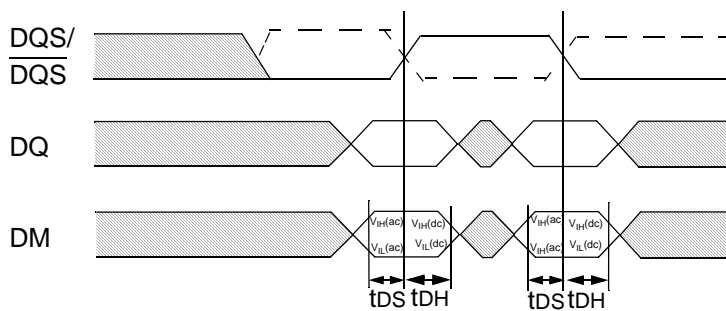
1. Write burst interrupt function is only allowed on burst of 8. Burst interrupt of 4 is prohibited.
2. Write burst of 8 can only be interrupted by another Write command. Write burst interruption by Read command or Precharge command is prohibited.
3. Write burst interrupt must occur exactly two clocks after previous Write command. Any other Write burst interrupt timings are prohibited.
4. Write burst interruption is allowed to any bank inside DRAM.
5. Write burst with Auto Precharge enabled is not allowed to interrupt.
6. Write burst interruption is allowed by another Write with Auto Precharge command.
7. All command timings are referenced to burst length set in the mode register. They are not referenced to actual burst. For example, minimum Write to Precharge timing is  $WL+BL/2+WR$  where WR starts with the rising clock after the un-interrupted burst end and not from the end of actual burst end.

**Figure 29. Write Burst Interrupt Timing Example: (CL=3, AL=0, RL=3, WL=2, BL=8)**

## 1.4.5 Write data mask

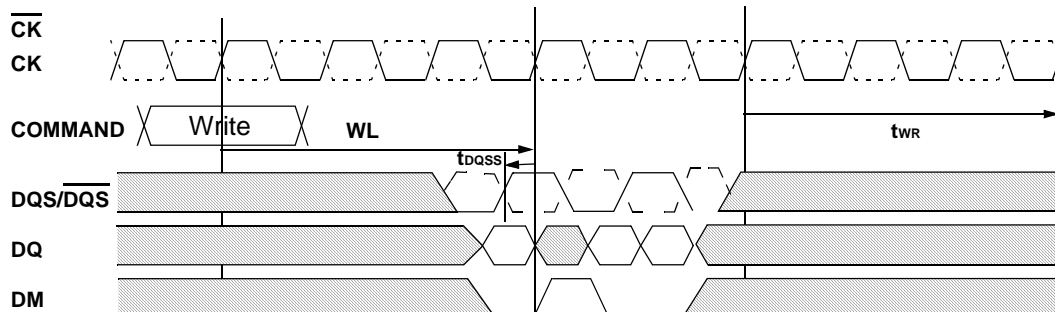
One write data mask (DM) pin for each 8 data bits (DQ) will be supported on DDR2 SDRAMs, Consistent with the implementation on DDR SDRAMs. It has identical timings on write operations as the data bits, and though used in a uni-directional manner, is internally loaded identically to data bits to insure matched system timing. DM of x4 and x16 bit organization is not used during read cycles. However DM of x8 bit organization can be used as RDQS during read cycles by EMR(1) setting.

### Data Mask Timing



### Data Mask Function, WL=3, AL=0, BL = 4 shown

#### Case 1 : min $t_{DQSS}$



#### Case 2 : max $t_{DQSS}$

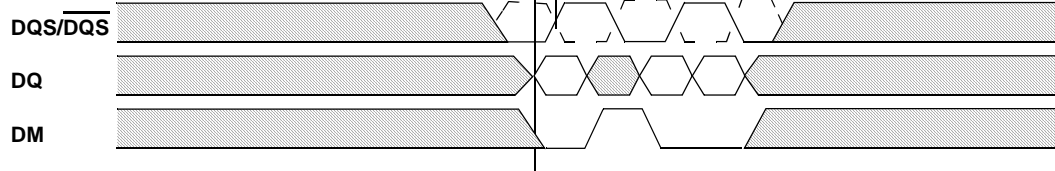


Figure 30. Write data mask

## 1.5 Precharge Operation

The Precharge Command is used to precharge or close a bank that has been activated. The Precharge Command is triggered when  $\overline{CS}$ ,  $\overline{RAS}$  and  $\overline{WE}$  are LOW and  $\overline{CAS}$  is HIGH at the rising edge of the clock. The Precharge Command can be used to precharge each bank independently or all banks simultaneously. Three address bits A10, BA0 and BA1 for 512Mb and four address bits A10, BA0~BA2 for 1Gb and higher densities are used to define which bank to precharge when the command is issued. For 8 bank devices, refer to Bank Active section of this data sheet.

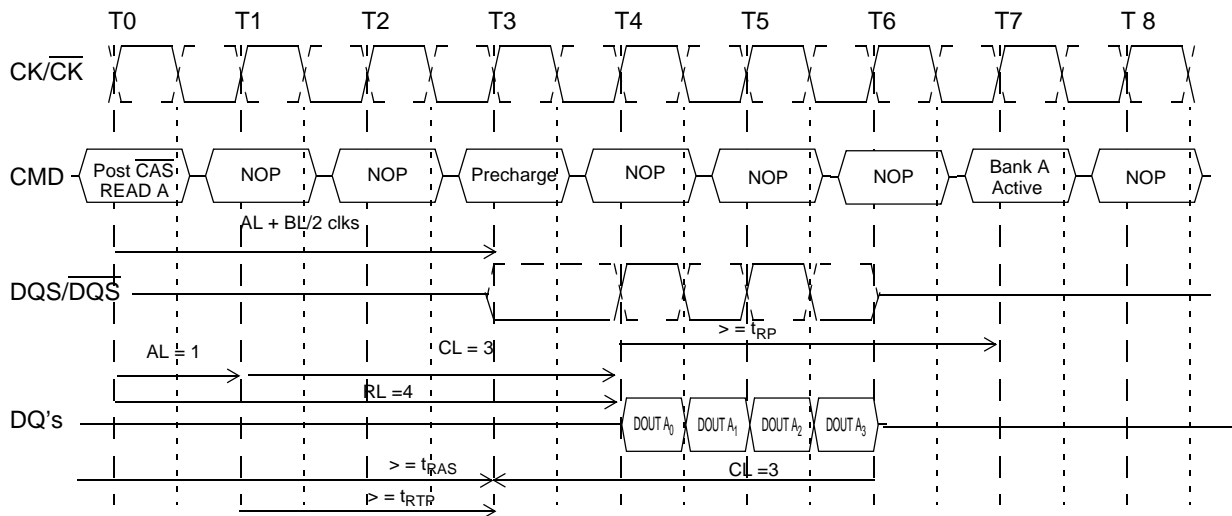
A10	BA2	BA1	BA0	Precharged Bank(s)	Remarks
LOW	LOW	LOW	LOW	Bank 0 only	
LOW	LOW	LOW	HIGH	Bank 1 only	
LOW	LOW	HIGH	LOW	Bank 2 only	
LOW	LOW	HIGH	HIGH	Bank 3 only	
LOW	HIGH	LOW	LOW	Bank 4 only	1Gb and higher
LOW	HIGH	LOW	HIGH	Bank 5 only	1Gb and higher
LOW	HIGH	HIGH	LOW	Bank 6 only	1Gb and higher
LOW	HIGH	HIGH	HIGH	Bank 7 only	1Gb and higher
HIGH	DON'T CARE	DON'T CARE	DON'T CARE	All Banks	

**Table 4. Bank selection for precharge by address bits**

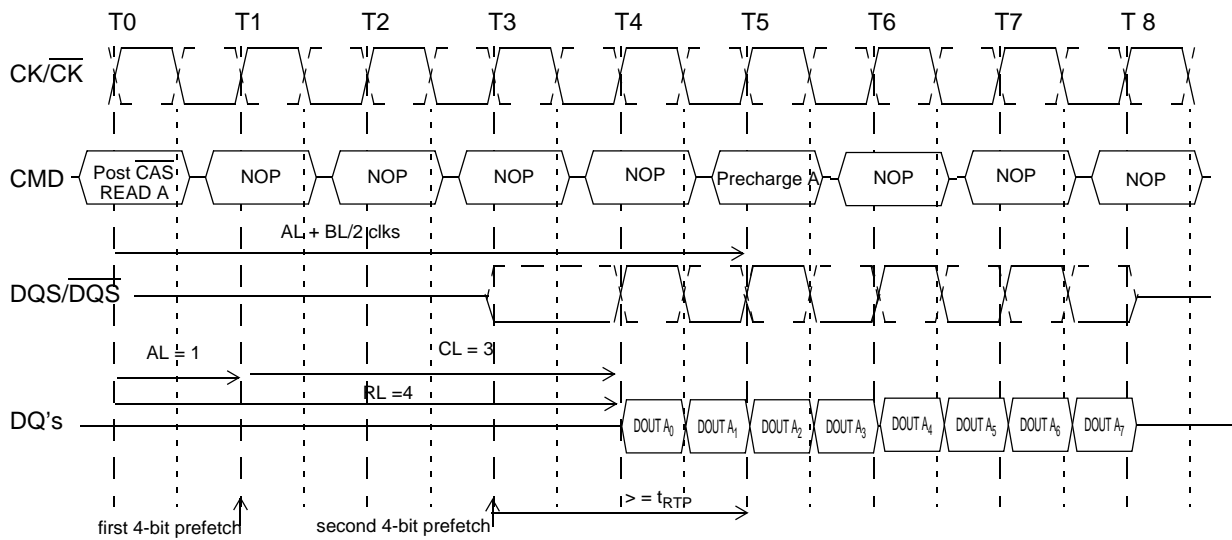
## Burst Read Operation Followed by Precharge

Minimum Read to precharge command spacing to the same bank =  $AL + BL/2 + \max(RTP, 2) - 2$  clocks  
 For the earliest possible precharge, the precharge command may be issued on the rising edge which is "Additive latency(AL) + BL/2 + max(RTP,2) - 2clocks" after a Read command. A new bank active (command) may be issued to the same bank after the RAS precharge time ( $t_{RP}$ ). A precharge command cannot be issued until  $t_{RAS}$  is satisfied.

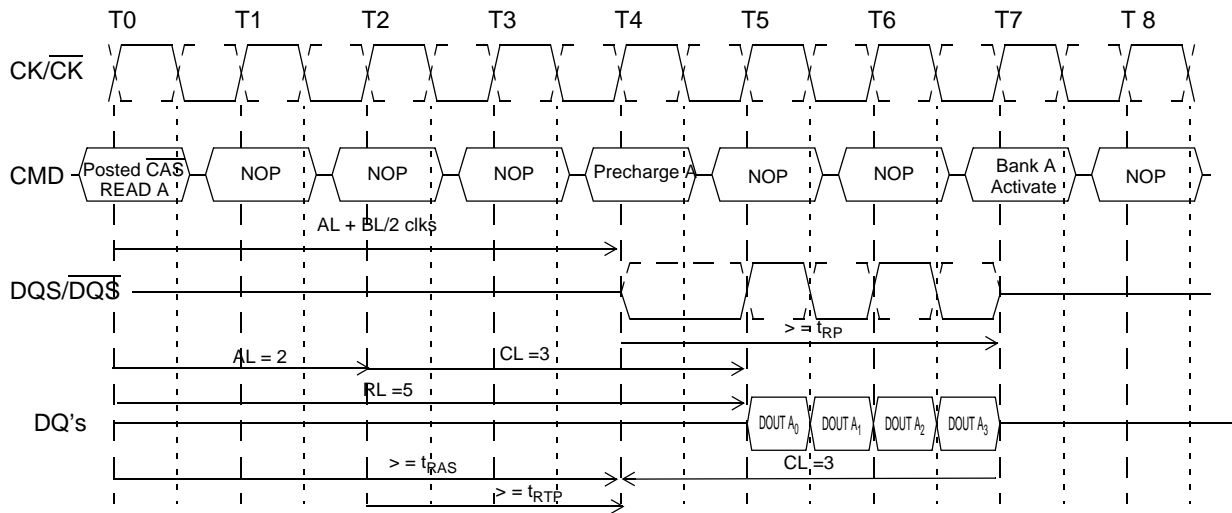
The minimum Read to Precharge spacing has also to satisfy a minimum analog time from the rising clock edge that initiates the last 4-bit prefetch of a Read to Precharge command. This time is called  $t_{RTP}$  (Read to Precharge). For BL = 4 this is the time from the actual read (AL after the Read command) to Precharge command. For BL = 8 this is the time from AL + 2 clocks after the Read to the Precharge command.



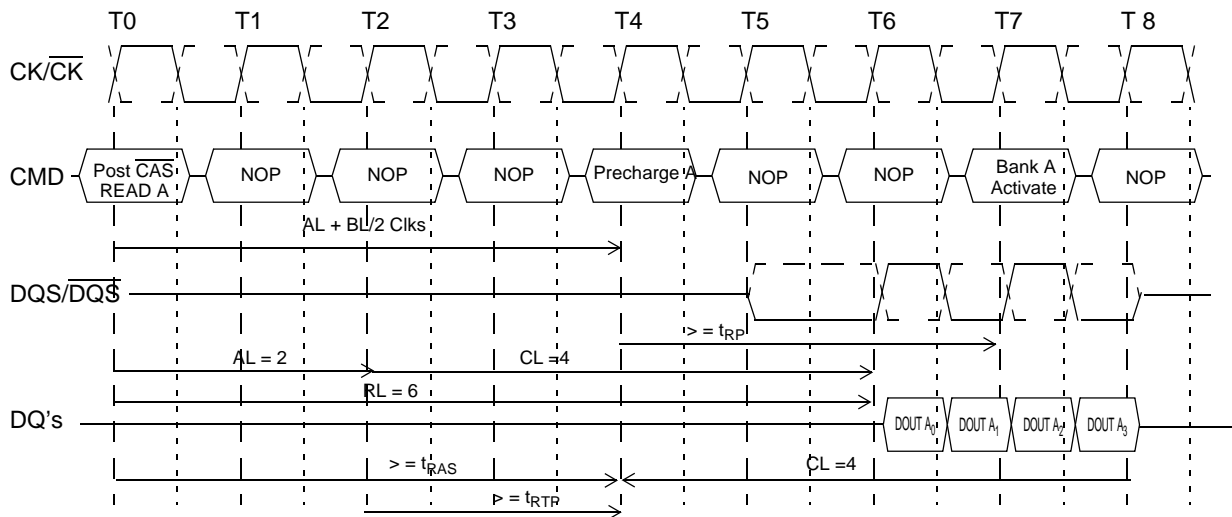
**Figure 31. Example 1: Burst Read Operation Followed by Precharge:**  
 $RL = 4, AL = 1, CL = 3, BL = 4, t_{RTP} \leq 2$  clocks



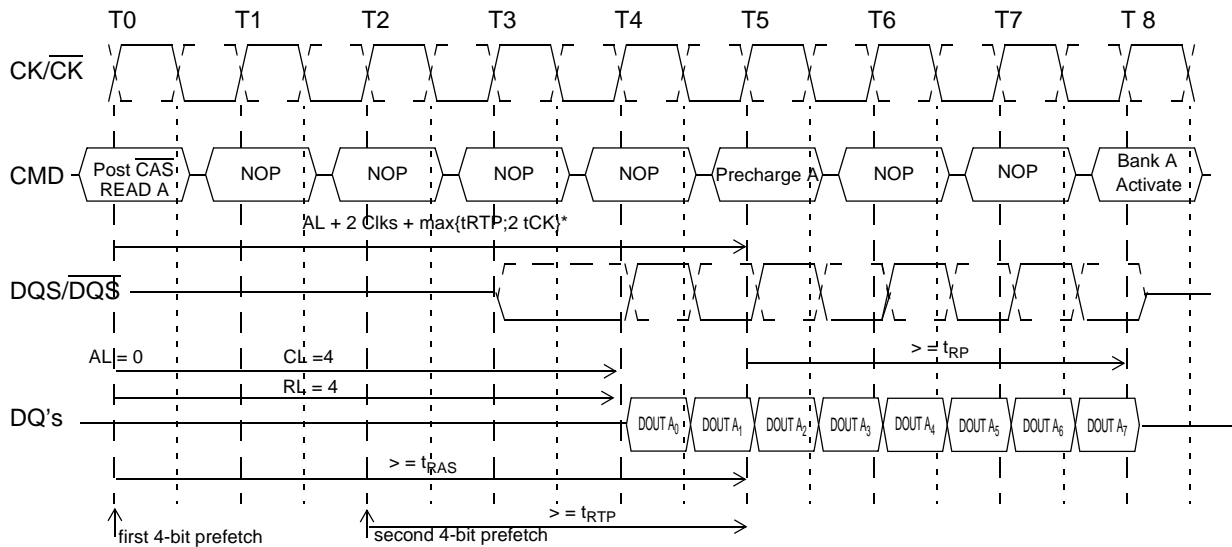
**Figure 32. Example 2: Burst Read Operation Followed by Precharge:**  
 $RL = 4, AL = 1, CL = 3, BL = 8, t_{RTP} \leq 2$  clocks



**Figure 33. Example 3: Burst Read Operation Followed by Precharge:**  
**RL = 5, AL = 2, CL = 3, BL = 4,  $t_{RTP} \leq 2$  clocks**



**Figure 34. Example 4: Burst Read Operation Followed by Precharge:**  
**RL = 6, AL = 2, CL = 4, BL = 4,  $t_{RTP} \leq 2$  clocks**



\* : rounded to next interger

**Figure 35. Example 5: Burst Read Operation Followed by Precharge:  
RL = 4, AL = 0, CL = 4, BL = 8, t<sub>RTP</sub> > 2 clocks**

## Burst Write followed by Precharge

Minimum Write to Precharge Command spacing to the same bank =  $WL + BL/2 \text{ clks} + tWR$   
 For write cycles, a delay must be satisfied from the completion of the last burst write cycle until the Precharge Command can be issued. This delay is known as a write recovery time ( $tWR$ ) referenced from the completion of the burst write to the precharge command. No Precharge command should be issued prior to the  $tWR$  delay.

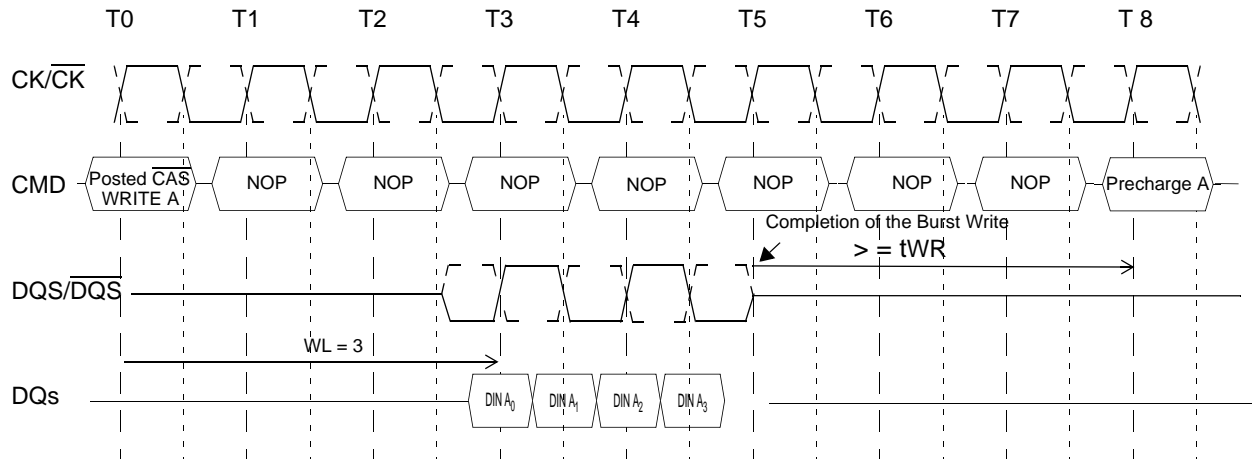


Figure 36. Example 1: Burst Write followed by Precharge:  $WL = (RL-1) = 3$

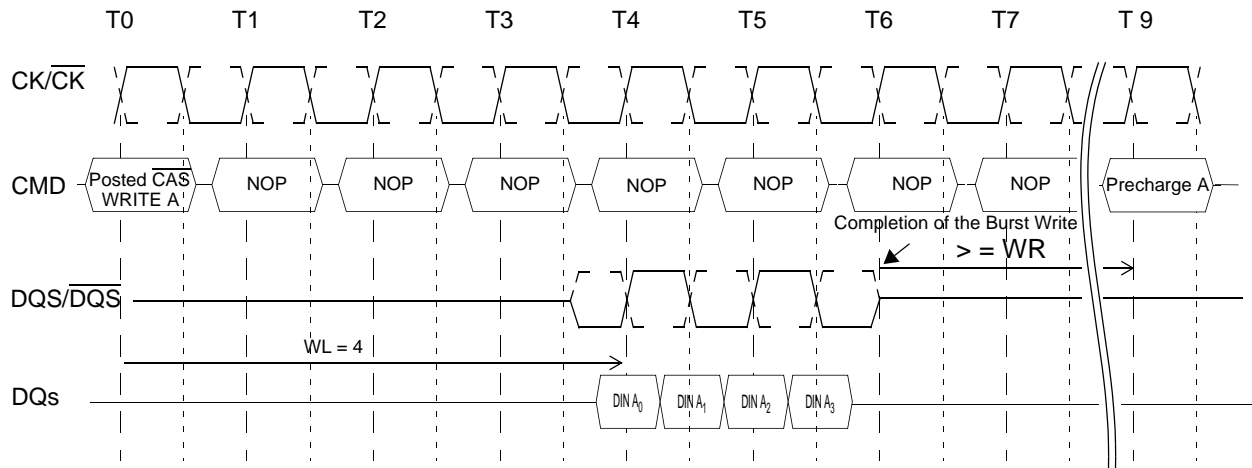


Figure 37. Example 2: Burst Write followed by Precharge:  $WL = (RL-1) = 4$

## 1.6 Auto Precharge Operation

Before a new row in an active bank can be opened, the active bank must be precharged using either the Precharge command or the auto-precharge function. When a Read or a Write command is given to the DDR2 SDRAM, the  $\overline{\text{CAS}}$  timing accepts one extra address, column address A10, to allow the active bank to automatically begin precharge at the earliest possible moment during the burst read or write cycle. If A10 is LOW when the READ or WRITE command is issued, then normal Read or Write burst operation is executed and the bank remains active at the completion of the burst sequence. If A10 is HIGH when the Read or Write command is issued, then the auto-precharge function is engaged. During auto-precharge, a Read command will execute as normal with the exception that the active bank will begin to precharge on the rising edge which is  $\overline{\text{CAS}}$  latency (CL) clock cycles before the end of the read burst.

Auto-precharge is also implemented during Write commands. The precharge operation engaged by the Auto precharge command will not begin until the last data of the burst write sequence is properly stored in the memory array.

This feature allows the precharge operation to be partially or completely hidden during burst read cycles (dependent upon  $\overline{\text{CAS}}$  latency) thus improving system performance for random data access. The  $\overline{\text{RAS}}$  lock-out circuit internally delays the Precharge operation until the array restore operation has been completed (tRAS satisfied) so that the auto precharge command may be issued with any read or write command.

### Burst Read with Auto Precharge

If A10 is HIGH when a Read Command is issued, the Read with Auto-Precharge function is engaged. The DDR2 SDRAM starts an Auto Precharge operation on the rising edge which is  $(\text{AL} + \text{BL}/2)$  cycles later than the read with AP command if tRAS(min) and tRTP(min) are satisfied.

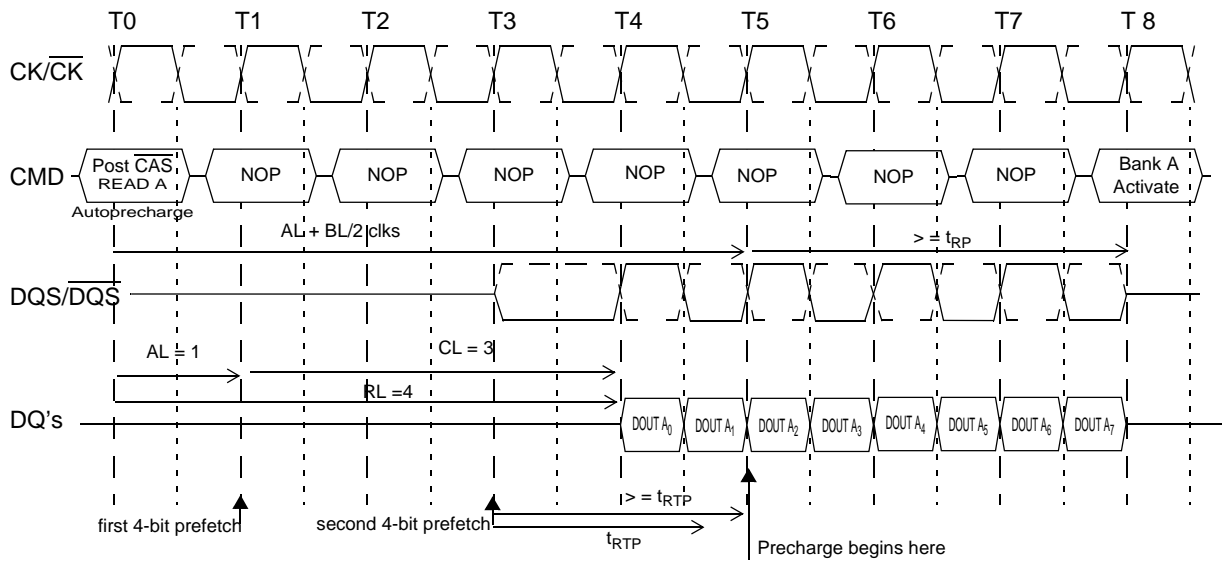
If tRAS(min) is not satisfied at the edge, the start point of auto-precharge operation will be delayed until tRAS(min) is satisfied.

If tRTP(min) is not satisfied at the edge, the start point of auto-precharge operation will be delayed until tRTP(min) is satisfied.

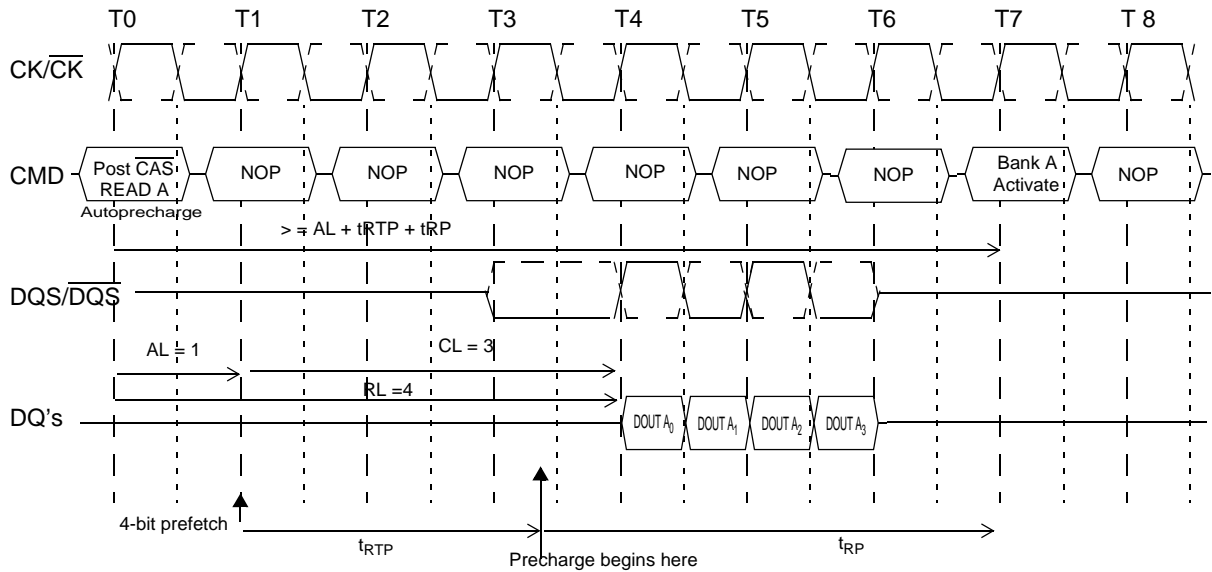
In case the internal precharge is pushed out by tRTP, tRP starts at the point where tRTP ends(not at the next rising clock edge after this event). So for BL = 4 the minimum time from Read\_AP to the next Activate command becomes  $\text{AL} + \{(t\text{RTP} + t\text{RP}) / t\text{CK}\}^*$  (see example 2) for BL = 8 the time from Read\_AP to the next Activate is  $\text{AL} + 2 + \{(t\text{RTP} + t\text{RP}) / t\text{CK}\}^*$ , where "\*" means: "rounded up to the next integer". These equations change to  $\text{AL} + \{t\text{RTP} + t\text{RP}\} / t\text{CK}(\text{avg})^*$  and  $\text{AL} + 2 + \{t\text{RTP} + t\text{RP}\} / t\text{CK}(\text{avg})^*$ , respectively, for DDR2-667/800. In any event internal precharge does not start earlier than two clocks after the last 4-bit prefetch.

A new bank activate (command) may be issued to the same bank if the following two conditions are satisfied simultaneously.

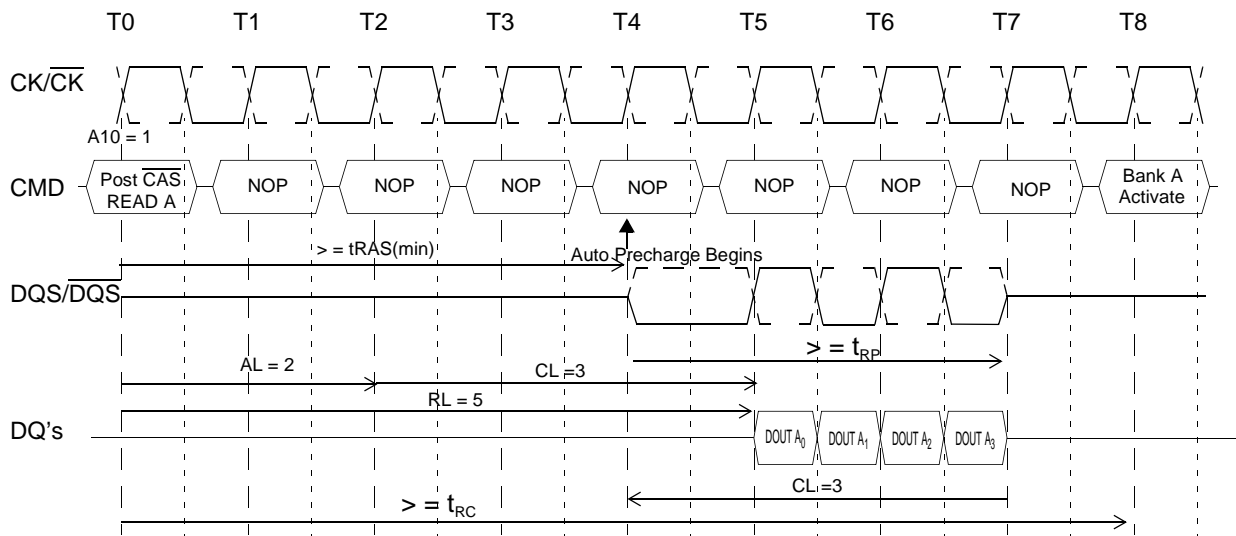
- (1) The  $\overline{\text{RAS}}$  precharge time (tRP) has been satisfied from the clock at which the auto precharge begins.
- (2) The  $\overline{\text{RAS}}$  cycle time (tRC) from the previous bank activation has been satisfied.



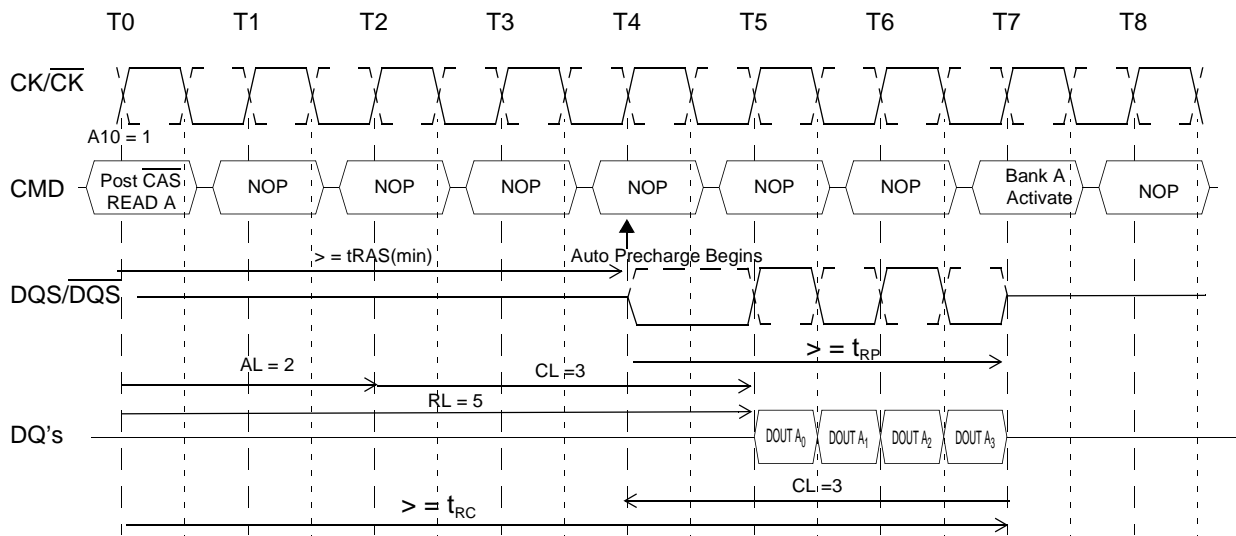
**Figure 38. Example 1: Burst Read Operation with Auto Precharge:**  
 $RL = 4, AL = 1, CL = 3, BL = 8, t_{RTP} \leq 2$  clocks



**Figure 39. Example 2: Burst Read Operation with Auto Precharge:**  
 $RL = 4, AL = 1, CL = 3, BL = 4, t_{RTP} > 2$  clocks



**Figure 40. Example 3: Burst Read with Auto Precharge Followed by an activation to the Same Bank( $t_{RC}$  Limit):**  
 $RL = 5$  ( $AL = 2$ ,  $CL = 3$ , internal  $t_{RCD} = 3$ ,  $BL = 4$ ,  $t_{RTP} \leq 2$  clocks)

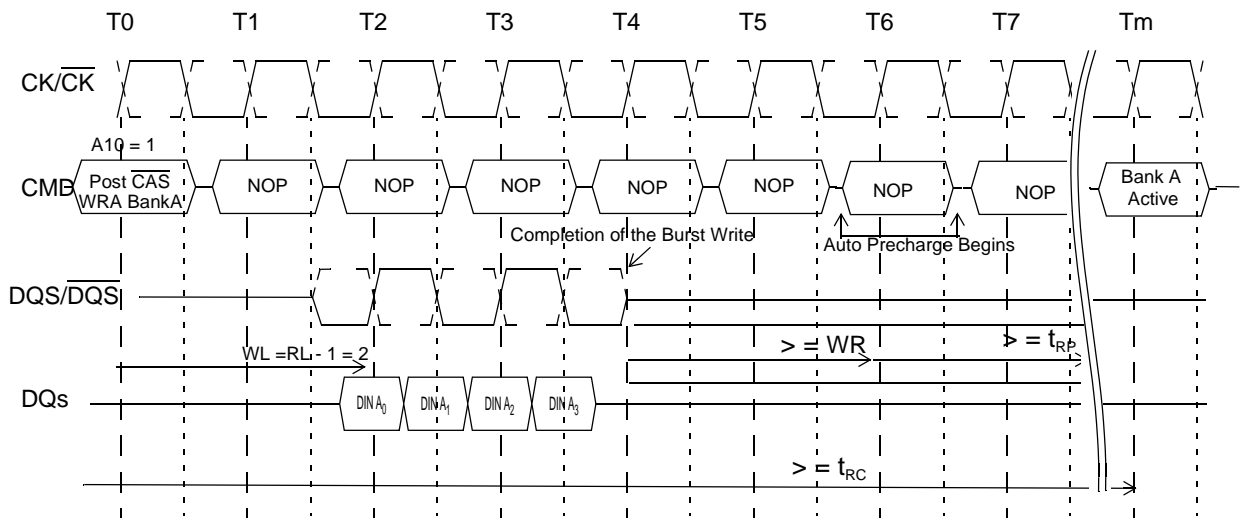


**Figure 41. Example 4: Burst Read with Auto Precharge Followed by an Activation to the Same Bank( $t_{RP}$  Limit):**  
 $RL = 5$  ( $AL = 2$ ,  $CL = 3$ , internal  $t_{RCD} = 3$ ,  $BL = 4$ ,  $t_{RTP} \leq 2$  clocks)

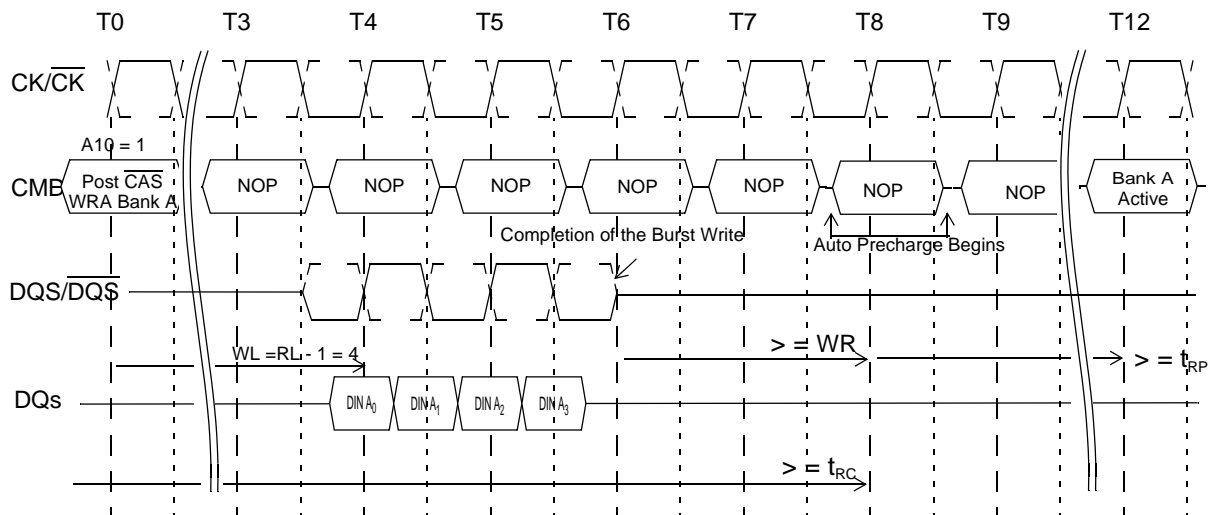
## Burst Write with Auto-Precharge

If A10 is HIGH when a Write Command is issued, the Write with Auto-Precharge function is engaged. The DDR2 SDRAM automatically begins precharge operation after the completion of the burst write plus write recovery time (WR) programmed in the mode register. The bank undergoing auto-precharge from the completion of the write burst may be reactivated if the following two conditions are satisfied.

- (1) The data-in to bank activate delay time ( $WR + t_{RP}$ ) has been satisfied.
- (2) The  $\overline{\text{RAS}}$  cycle time ( $t_{RC}$ ) from the previous bank activation has been satisfied.



**Figure 42. Burst Write with Auto-Precharge ( $t_{RC}$  Limit):**  
**WL = 2, WR = 2, BL = 4,  $t_{RP}$  = 3**



**Figure 43. Burst Write with Auto-Precharge ( $WR + t_{RP}$ ):**  
**WL = 4, WR = 2, BL = 4,  $t_{RP}$  = 3**

## Precharge & Auto Precharge Clarification

From Command	To Command	Minimum Delay between "From Command" to "To Command"	Unit	Notes
Read	Precharge(to same Bank as Read)	$AL + BL/2 + \max(RTP, 2) - 2$	clks	1,2
	Precharge All	$AL + BL/2 + \max(RTP, 2) - 2$	clks	1,2
Read w/AP	Precharge(to same Bank as Read w/AP)	$AL + BL/2 + \max(RTP, 2) - 2$	clks	1,2
	Precharge All	$AL + BL/2 + \max(RTP, 2) - 2$	clks	1,2
Write	Precharge(to same Bank as Read)	$WL + BL/2 + WR$	clks	2
	Precharge All	$WL + BL/2 + WR$	clks	2
Write w/AP	Precharge(to same Bank as Read)	$WL + BL/2 + WR$	clks	2
	Precharge All	$WL + BL/2 + WR$	clks	2
Precharge	Precharge(to same Bank as Read)	1	clks	2
	Precharge All	1	clks	2
Precharge All	Precharge	1	clks	2
	Precharge All	1	clks	2

Note 1:  $RTP[\text{cycles}] = RU\{tRTP(\text{ns})/tCK(\text{ns})\}$ , where RU stands for round up.  $tCK(\text{avg})$  should be used in place of  $tCK$  for DDR2-667/800.

Note 2: For a given bank, the precharge period should be counted from the latest precharge command, either one bank precharge or precharge all, issued to that bank. The precharge period is satisfied after  $tRP$  or  $tRP_{\text{all}}$  ( $=tRP$  for 4 bank device,  $=tRP + 1*tCK$  for 8 bank device) depending on the latest precharge command issued to that bank

**Table 5. Precharge & auto precharge clarification**

## 1.7 Refresh Commands

DDR2 SDRAMs require a refresh of all rows in any rolling 64 ms interval. Each refresh is generated in one of two ways: by an explicit Auto-Refresh command, or by an internally timed event in SELF REFRESH mode. Dividing the number of device rows into the rolling 64ms interval,  $tREFI$ , which is a guideline to controllers for distributed refresh timing. For example, a 512Mb DDR2 SDRAM has 8192 rows resulting in a  $tREFI$  of  $7.8\mu\text{s}$ . To avoid excessive interruptions to the memory controller, higher density DDR2 SDRAMs maintain  $7.8\mu\text{s}$  average refresh time and perform multiple internal refresh bursts. In these cases, the refresh recovery times,  $tRFC$  and  $tXSNR$  are extended to accommodate these internal operations.

### 1.7.1 Auto Refresh Command

AUTO REFRESH is used during normal operation of the DDR2 SDRAM. This command is nonpersistent, so it must be issued each time a refresh is required. The refresh addressing is generated by the internal refresh controller. This makes the address bits "Don't Care" during an AUTO REFRESH command.

When CS, RAS and CAS are held LOW and  $\overline{WE}$  HIGH at the rising edge of the clock, the chip enters the Refresh mode (REF). All banks of the DDR2 SDRAM must be precharged and idle for a minimum of the Precharge time ( $tRP$ ) before the Refresh command (REF) can be applied. An address counter, internal to the device, supplies the bank address during the refresh cycle. No control of the external address bus is required once this cycle has started.

When the refresh cycle has completed, all banks of the DDR2 SDRAM will be in the precharged (idle) state. A delay between the Refresh command (REF) and the next Activate command or subsequent Refresh command must be greater than or equal to the Refresh cycle time ( $tRFC$ ).

To allow for improved efficiency in scheduling and switching between tasks, some flexibility in the absolute refresh interval is provided. A maximum of eight Refresh commands can be posted to any given DDR2 SDRAM, meaning that the maximum absolute interval between any Refresh command and the next Refresh command is  $9 * t_{REFI}$ .

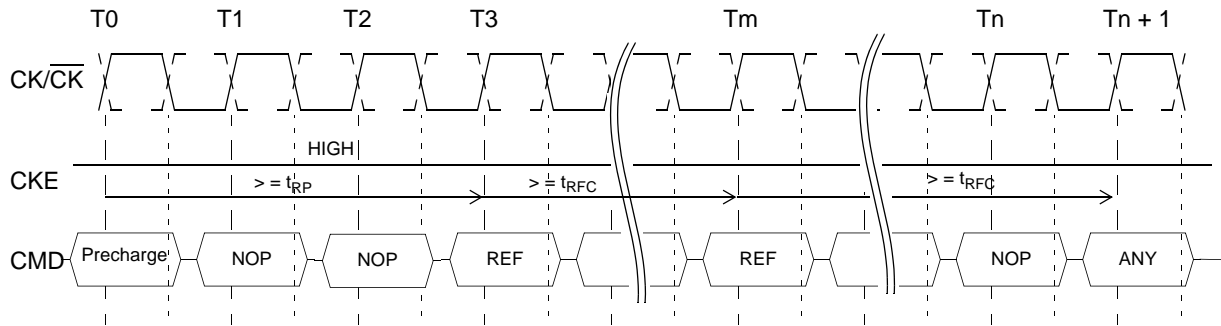


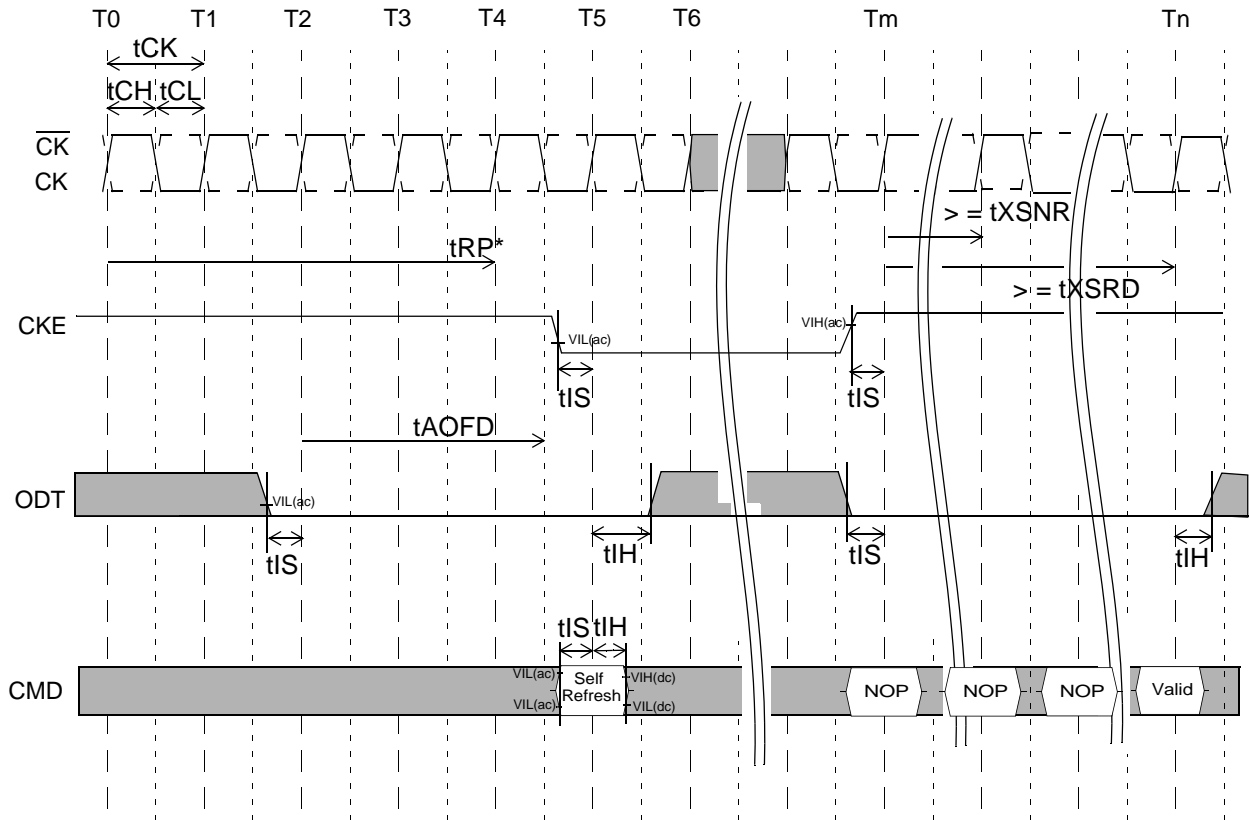
Figure 44. Refresh command

## 1.7.2 Self Refresh Operation

The Self Refresh command can be used to retain data in the DDR2 SDRAM, even if the rest of the system is powered down. When in the Self Refresh mode, the DDR2 SDRAM retains data without external clocking. The DDR2 SDRAM device has a built-in timer to accommodate Self Refresh operation. The Self Refresh Command is defined by having CS, RAS, CAS and CKE held LOW with WE HIGH at the rising edge of the clock. ODT must be turned off before issuing Self Refresh command, by either driving ODT pin LOW or using EMR command. Once the Command is registered, CKE must be held LOW to keep the device in Self Refresh mode. The DLL is automatically disabled upon entering Self Refresh and is automatically enabled upon existing Self Refresh. When the DDR2 SDRAM has entered Self Refresh mode all of the external signals except CKE, are “don’t care”. The DRAM initiates a minimum of one Auto Refresh command internally within tCKE period once it enters Self Refresh mode. The clock is internally disabled during Self Refresh Operation to save power. The minimum time that the DDR2 SDRAM must remain in Self Refresh mode is tCKE. The user may change the external clock frequency or halt the external clock one clock after Self-Refresh entry is registered, however, the clock must be restarted and stable before the device can exit Self Refresh operation.

The procedure for existing Self Refresh requires a sequence of commands. First, the clock must be stable prior to CKE going back HIGH. Once Self Refresh Exit command is registered, a delay equal or longer than the tXSNR or tXSRD must be satisfied before a valid command can be issued to the device. CKE must remain HIGH for the entire Self Refresh exit period tXSRD for proper operation. Upon exit from Self Refresh, the DDR2 SDRAM can be put back into Self Refresh mode after tXSRD expires. NOP or deselect commands must be registered on each positive clock edge during the Self Refresh exit interval. ODT should also be turned off during tXSRD.

The Use of Self Refresh mode introduce the possibility that an internally timed refresh event can be missed when CKE is raised for exit from Self Refresh mode. Upon exit from Self Refresh, the DDR2 SDRAM requires a minimum of one extra auto refresh command before it is put back into Self Refresh mode.



- Device must be in the "All banks idle" state prior to entering Self Refresh mode.
- ODT must be turned off  $t_{AOFD}$  before entering Self Refresh mode, and can be turned on again when  $t_{XSRD}$  timing is satisfied.
- $t_{XSRD}$  is applied for a Read or a Read with autprecharge command
- $t_{XSNR}$  is applied for any command except a Read or a Read with autprecharge command.

**Figure 45. Self refresh operation**

## 1.8 Power-Down

Power-down is synchronously entered when CKE is registered LOW (along with Nop or Deselect command). CKE is not allowed to go LOW while mode register or extended mode register command time, or read or write operation is in progress. CKE is allowed to go LOW while any of other operations such as row activation, pre-charge or autoprecharge, or auto-refresh is in progress, but power-down IDD spec will not be applied until finishing those operations. Timing diagrams are shown in the following pages with details for entry into power down.

The DLL should be in a locked state when power-down is entered. Otherwise DLL should be reset after exiting power-down mode for proper read operation. DRAM design guarantees its DLL in a locked state with any CKE intensive operations as long as DRAM controller complies with DRAM specifications. Figure X and figure Y show two examples of CKE intensive applications. In both examples, DRAM maintains DLL in a locked state throughout the period.

If power-down occurs when all banks are idle, this mode is referred to as precharge power-down; if power-down occurs when there is a row active in any bank, this mode is referred to as active power-down. Entering power-down deactivates the input and output buffers, excluding CK,  $\overline{\text{CK}}$ , ODT and CKE. Also the DLL is disabled upon entering precharge power-down or slow exit active power-down, but the DLL is kept enabled during fast exit active power-down. In power-down mode, CKE LOW and a stable clock signal must be maintained at the inputs of the DDR2 SDRAM, and ODT should be in a valid state but all other input signals are "Don't Care". CKE LOW must be maintained until t<sub>CKE</sub> has been satisfied. Maximum Power-down duration is limited by the refresh requirements of the device, which allows a maximum of 9\*t<sub>REFI</sub> if maximum post-ing of REF is utilized immediately before entering power down.

The power-down state is synchronously exited when CKE is registered HIGH (along with a Nop or Deselect command). CKE HIGH must be maintained until t<sub>CKE</sub> has been satisfied. A valid, executable command can be applied with power-down exit latency, t<sub>XP</sub>, t<sub>XARD</sub>, or t<sub>XARDS</sub>, after CKE goes HIGH. Power-down exit latency is defined in the AC spec table of this data sheet.

### Basic Power Down Entry and Exit timing diagram

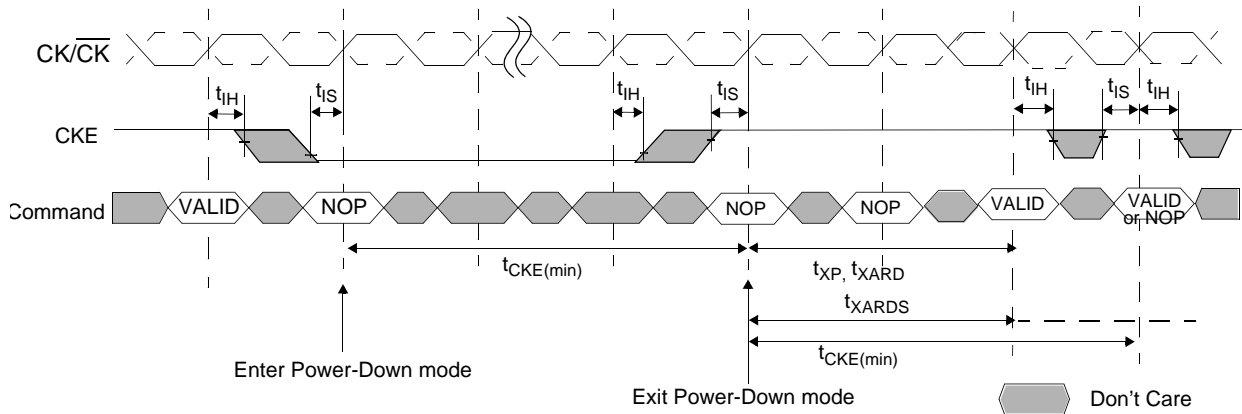


Figure 46. Basic power down entry and exit timing diagram

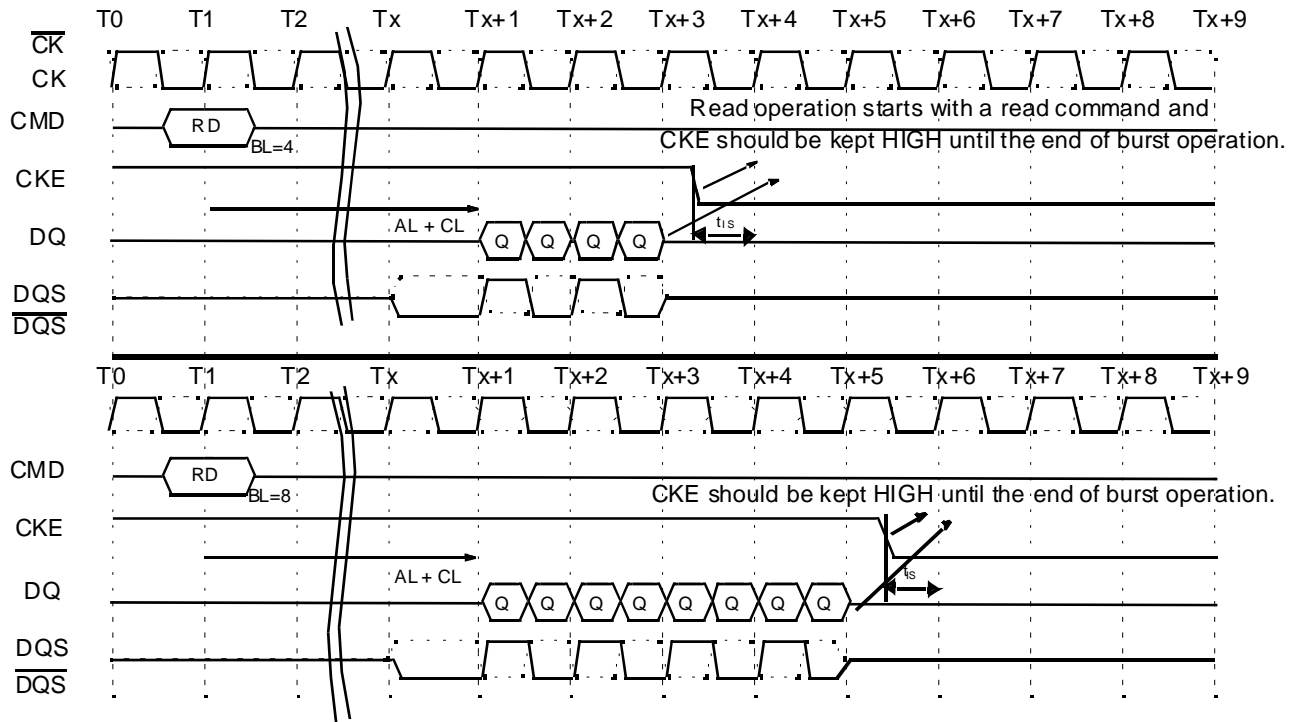


Figure 47. Read to power down entry

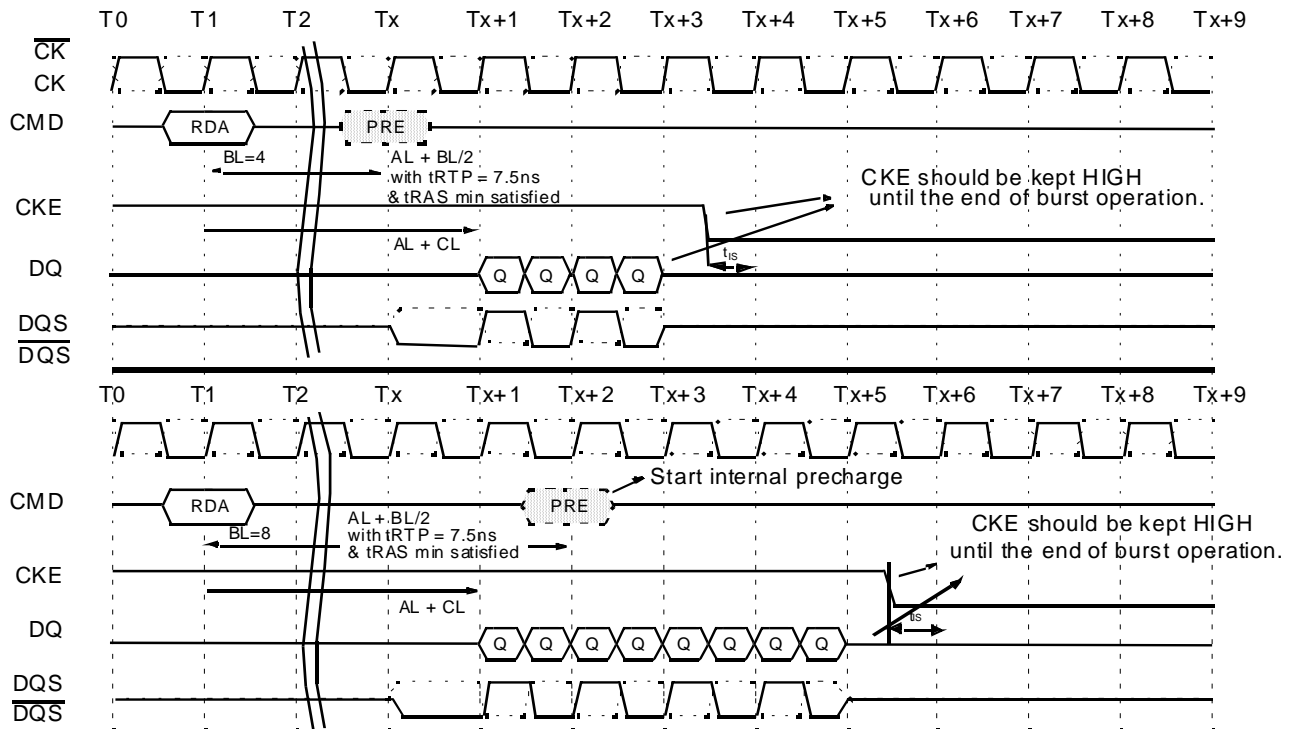


Figure 48. Read with autoprecharge to power

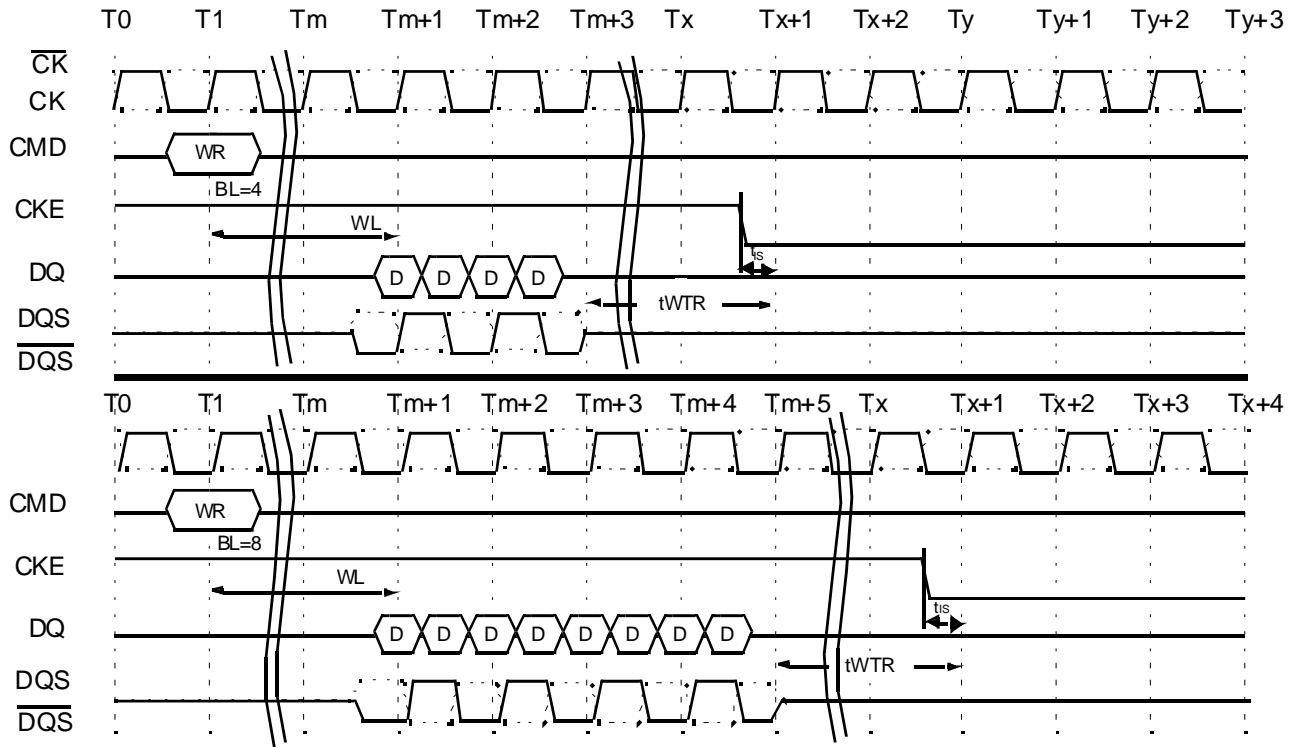


Figure 49. Write to power down entry

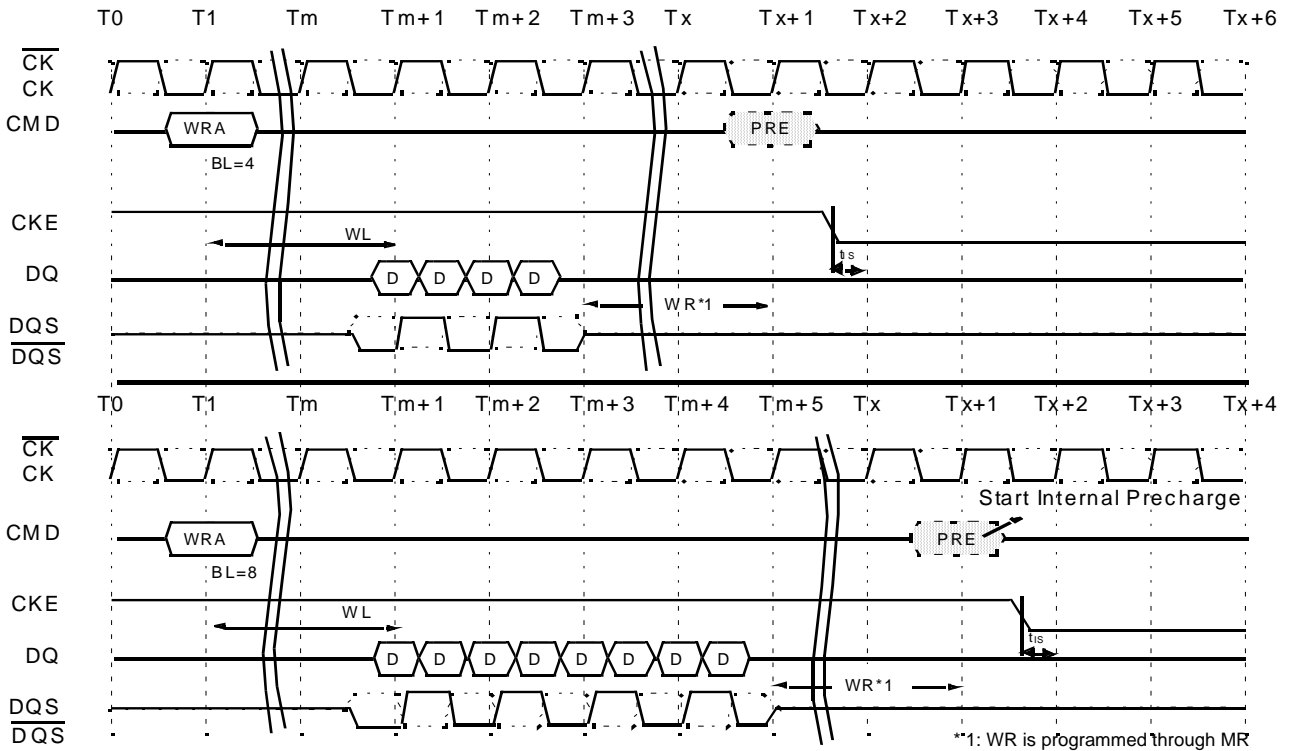
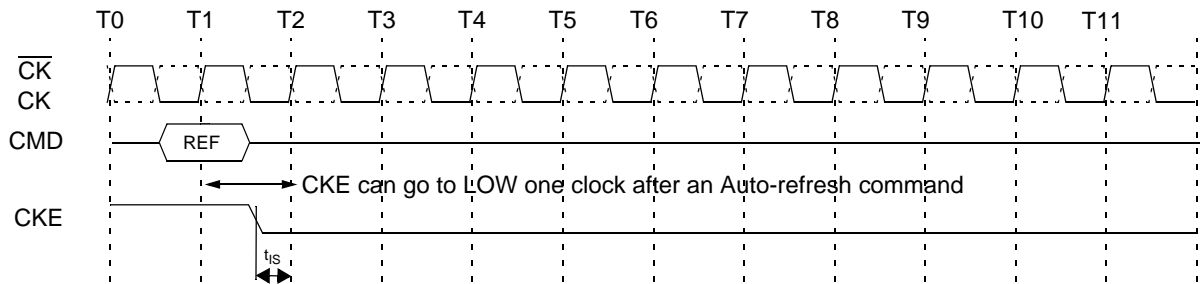
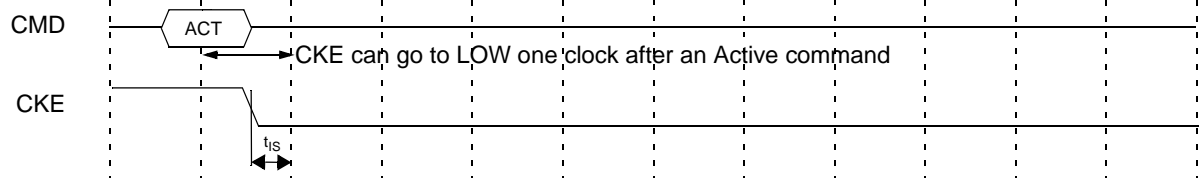


Figure 50. Write with Autoprecharge to power down entry

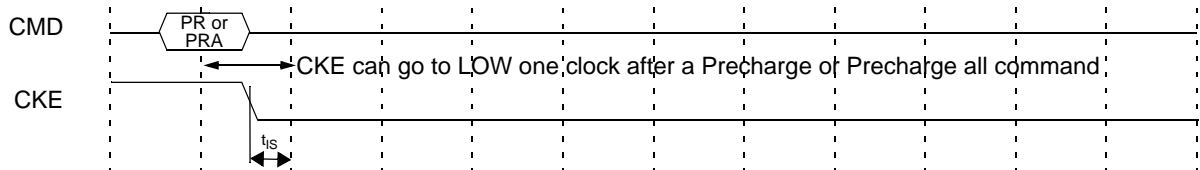
\*\*1: WR is programmed through MR



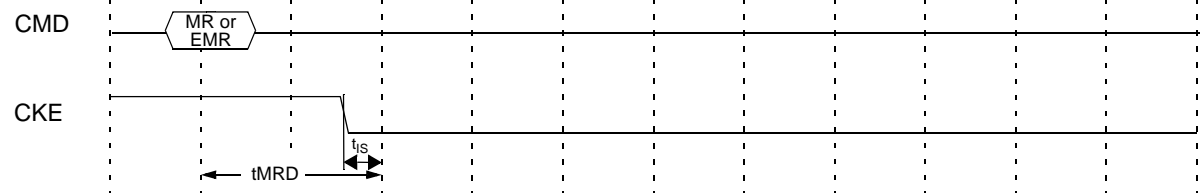
**Figure 51. Refresh command to power down entry**



**Figure 52. Active command to power down entry**



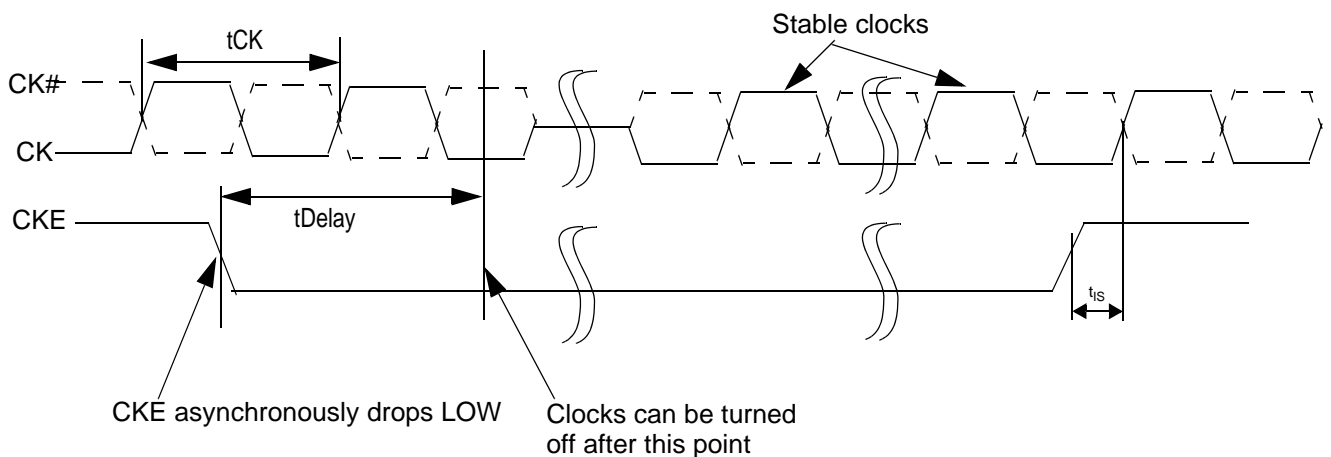
**Figure 53. Precharge/Precharge all command to power down entry**



**Figure 54. MR/EMR command to power down entry**

## 1.9 Asynchronous CKE LOW Event

DRAM requires CKE to be maintained "HIGH" for all valid operations as defined in this data sheet. If CKE asynchronously drops "LOW" during any valid operation DRAM is not guaranteed to preserve the contents of array. If this event occurs, memory controller must satisfy DRAM timing specification  $t_{Delay}$  before turning off the clocks. Stable clocks must exist at the input of DRAM before CKE is raised "HIGH" again. DRAM must be fully re-initialized (steps 4 thru 13) as described in initialization sequence. DRAM is ready for normal operation after the initialization sequence. See AC timing parametric table for  $t_{Delay}$  specification



**Figure 55. Asynchronous CKE LOW event**

## Input Clock Frequency Change during Precharge Power Down

DDR2 SDRAM input clock frequency can be changed under following condition:

DDR2 SDRAM is in precharged power down mode. ODT must be turned off and CKE must be at logic LOW level. A minimum of 2 clocks must be waited after CKE goes LOW before clock frequency may change. SDRAM input clock frequency is allowed to change only within minimum and maximum operating frequency specified for the particular speed grade. During input clock frequency change, ODT and CKE must be held at stable LOW levels. Once input clock frequency is changed, stable new clocks must be provided to DRAM before precharge power down may be exited and DLL must be RESET via EMR after precharge power down exit. Depending on new clock frequency an additional MR command may need to be issued to appropriately set the WR, CL etc.. During DLL re-lock period, ODT must remain off. After the DLL lock time, the DRAM is ready to operate with new clock frequency.

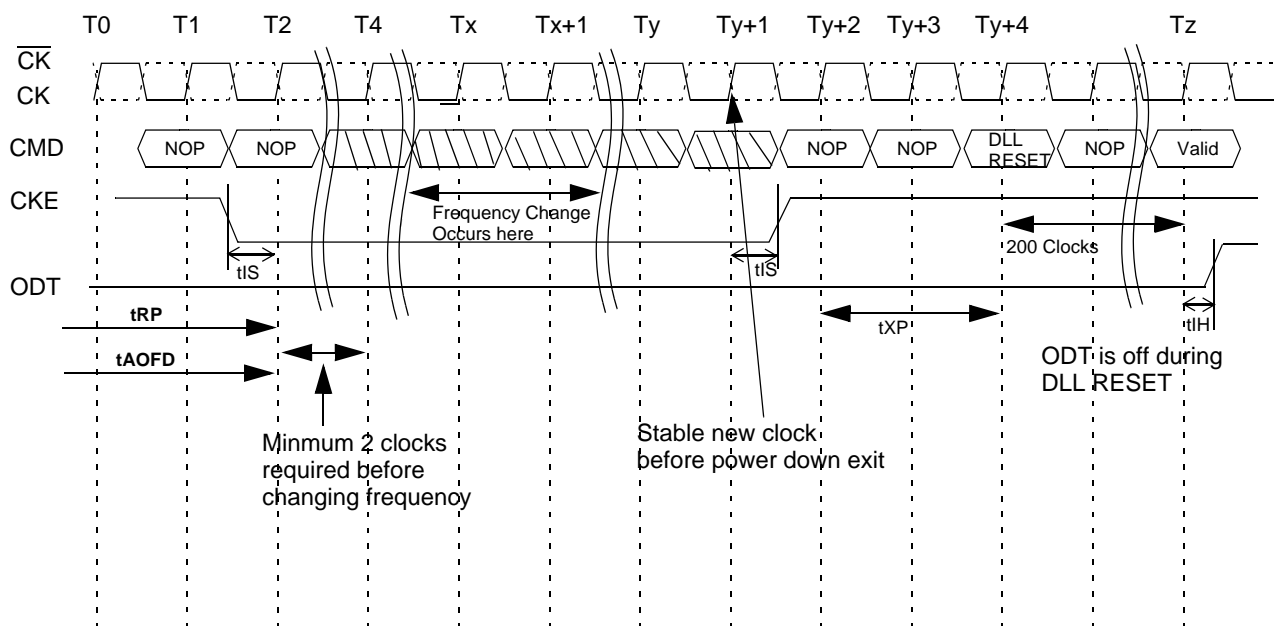


Figure 56. Clock Frequency Change in Precharge Power Down Mode

### 1.10 No Operation Command

The No Operation command should be used in cases when the DDR2 SDRAM is in an idle or a wait state. The purpose of the No Operation command (NOP) is to prevent the DDR2 SDRAM from registering any unwanted commands between operations. A No Operation command is registered when  $\overline{CS}$  is LOW with  $\overline{RAS}$ ,  $\overline{CAS}$ , and  $\overline{WE}$  held HIGH at the rising edge of the clock. A No Operation command will not terminate a previous operation that is still executing, such as a burst read or write cycle.

### 1.11 Deselect Command

The Deselect command performs the same function as a No Operation command. Deselect command occurs when CS is brought HIGH at the rising edge of the clock, the RAS, CAS, and WE signals become don't cares.

## 2. Truth Tables

### 2.1 Command truth table.

Function	CKE		$\overline{CS}$	$\overline{RAS}$	$\overline{CAS}$	$\overline{WE}$	BA0 BA1 BA2	A15-A11	A10	A9 - A0	Notes
	Previous Cycle	Current Cycle									
(Extended) Mode Register	H	H	L	L	L	L	BA	OP Code			1,2
Refresh (REF)	H	H	L	L	L	H	X	X	X	X	1
Self Refresh Entry	H	L	L	L	L	H	X	X	X	X	1
Self Refresh Exit	L	H	H	X	X	X	X	X	X	X	1,7
			L	H	H	H					
Single Bank Precharge	H	H	L	L	H	L	BA	X	L	X	1,2
Precharge all Banks	H	H	L	L	H	L	X	X	H	X	1
Bank Activate	H	H	L	L	H	H	BA	Row Address			1,2
Write	H	H	L	H	L	L	BA	Column	L	Column	1,2,3,
Write with Auto Precharge	H	H	L	H	L	L	BA	Column	H	Column	1,2,3,
Read	H	H	L	H	L	H	BA	Column	L	Column	1,2,3
Read with Auto-Precharge	H	H	L	H	L	H	BA	Column	H	Column	1,2,3
No Operation	H	X	L	H	H	H	X	X	X	X	1
Device Deselect	H	X	H	X	X	X	X	X	X	X	1
Power Down Entry	H	L	H	X	X	X	X	X	X	X	1,4
			L	H	H	H					
Power Down Exit	L	H	H	X	X	X	X	X	X	X	1,4
			L	H	H	H					

1. All DDR2 SDRAM commands are defined by states of  $\overline{CS}$ ,  $\overline{RAS}$ ,  $\overline{CAS}$ ,  $\overline{WE}$  and CKE at the rising edge of the clock.
2. Bank addresses BA0, BA1, BA2 (BA) determine which bank is to be operated upon. For (E)MR BA selects an (Extended) Mode Register.
3. Burst reads or writes at BL=4 cannot be terminated or interrupted. See sections "Reads interrupted by a Read" and "Writes interrupted by a Write" in section 1.4 for details.
4. The Power Down Mode does not perform any refresh operations. The duration of Power Down is therefore limited by the refresh requirements outlined in section 1.2.2.
5. The state of ODT does not affect the states described in this table. The ODT function is not available during Self Refresh. See section 1.2.2.4.
6. "X" means "H or L (but a defined logic level)".
7. Self refresh exit is asynchronous.
8. VREF must be maintained during Self Refresh operation

**Table 6. Command truth table**

## 2.2 Clock Enable (CKE) Truth Table for Synchronous

Current State <sup>2</sup>	CKE		Command (N) <sup>3</sup> $\overline{\text{RAS}}, \overline{\text{CAS}}, \overline{\text{WE}}, \overline{\text{CS}}$	Action (N) <sup>3</sup>	Notes
	Previous Cycle <sup>1</sup> (N-1)	Current Cycle <sup>1</sup> (N)			
Power Down	L	L	X	Maintain Power-Down	11, 13, 15
	L	H	DESELECT or NOP	Power Down Exit	4, 8, 11,13
Self Refresh	L	L	X	Maintain Self Refresh	11, 15
	L	H	DESELECT or NOP	Self Refresh Exit	4, 5,9,16
Bank(s) Active	H	L	DESELECT or NOP	Active Power Down Entry	4,8,10,11,13
All Banks Idle	H	L	DESELECT or NOP	Precharge Power Down Entry	4, 8, 10,11,13
	H	L	REFRESH	Self Refresh Entry	6, 9, 11,13
	H	H	Refer to the Command Truth Table		7

**Notes:**

1. CKE (N) is the logic state of CKE at clock edge N; CKE (N-1) was the state of CKE at the previous clock edge.
2. Current state is the state of the DDR SDRAM immediately prior to clock edge N.
3. COMMAND (N) is the command registered at clock edge N, and ACTION (N) is a result of COMMAND (N).
4. All states and sequences not shown are illegal or reserved unless explicitly described elsewhere in this document.
5. On Self Refresh Exit DESELECT or NOP commands must be issued on every clock edge occurring during the  $t_{XSNR}$  period. Read commands may be issued only after  $t_{XSRD}$  (200 clocks) is satisfied.
6. Self Refresh mode can only be entered from the All Banks Idle state.
7. Must be a legal command as defined in the Command Truth Table.
8. Valid commands for Power Down Entry and Exit are NOP and DESELECT only.
9. Valid commands for Self Refresh Exit are NOP and DESELECT only.
10. Power Down and Self Refresh can not be entered while Read or Write operations, (Extended) Mode Register operations or Precharge operations are in progress. See section 1.8 "Power Down" and 1.7.2 "Self Refresh Command" for a detailed list of restrictions.
11.  $t_{CKEMin}$  of 3 clocks means CKE must be registered on three consecutive positive clock edges. CKE must remain at the valid input level the entire time it takes to achieve the 3 clocks of registration. Thus, after any CKE transition, CKE may not transition from its valid level during the time period of  $tIS + 2 \cdot tCKE + tIH$ .
12. The state of ODT does not affect the states described in this table. The ODT function is not available during Self Refresh. See section 1.2.2.4.
13. The Power Down does not perform any refresh operations. The duration of Power Down Mode is therefore limited by the refresh requirements outlined in section 1.2.2.
14. CKE must be maintained HIGH while the SDRAM is in OCD calibration mode .
15. "X" means "don't care (including floating around VREF)" in Self Refresh and Power Down. However ODT must be driven HIGH or LOW in Power Down if the ODT function is enabled (Bit A2 or A6 set to "1" in EMR(1) ).
16.  $V_{REF}$  must be maintained during Self Refresh operation.

**Table 7. Clock enable(CKE) truth table for synchronous transitions**

## 2.3 Data Mask Truth Table

Name (Functional)	DM	DQs	Note
Write enable	L	Valid	1
Write inhibit	H	X	1

1. Used to mask write data, provided coincident with the corresponding data

**Table 8. Data mask truth table**

## 3. Maximum DC Ratings

### 3.1 Absolute Maximum DC Ratings

Symbol	Parameter	Rating	Units	Notes
VDD	Voltage on VDD pin relative to Vss	- 1.0 V ~ 2.3 V	V	1,3
VDDQ	Voltage on VDDQ pin relative to Vss	- 0.5 V ~ 2.3 V	V	1,3
VDDL	Voltage on VDDL pin relative to Vss	- 0.5 V ~ 2.3 V	V	1,3
V <sub>IN</sub> , V <sub>OUT</sub>	Voltage on any pin relative to Vss	- 0.5 V ~ 2.3 V	V	1
T <sub>STG</sub>	Storage Temperature	-55 to +100	°C	1, 2

1. Stresses greater than those listed under “Absolute Maximum Ratings” may cause permanent damage to the device. This is a stress rating only and functional operation of the device at these or any other conditions above those indicated in the operational sections of this specification is not implied. Exposure to absolute maximum rating conditions for extended periods may affect reliability.

2. Storage Temperature is the case surface temperature on the center/top side of the DRAM. For the measurement conditions. Please refer to JESD51-2 standard.

3. VDD and VDDQ must be within 300mV of each other at all times; and VREF must be not greater than 0.6xVDDQ. When VDD and VDDQ and VDDL are less than 500mV, Vref may be equal to or less than 300mV.

**Table 9. Absolute maximum DC ratings**

### 3.2 Operating Temperature Condition

Symbol	Parameter	Rating	Units	Notes
T <sub>OPER</sub>	Operating Temperature	0 to 85	°C	1,2

1. Operating Temperature is the case surface temperature on the center/top side of the DRAM. For the measurement conditions, please refer to JESD51-2 standard.

2. The operating temperature range are the temperature where all DRAM specification will be supported. Outside of this temperature range, even it is still within the limit of stress condition, some deviation on portion of operation specification may be required. During operation, the DRAM case temperature must be maintained between 0 ~ 85°C under all other specification parameters. However, in some applications, it is desirable to operate the DRAM up to 95°C case temperature. Therefore 2 spec options may exist.

- 1) Supporting 0 - 85°C with full JEDEC AC & DC specifications. This is the minimum requirements for all operating temperature options.
- 2) Supporting 0 - 85°C and being able to extend to 95°C with doubling auto-refresh commands in frequency to a 32 ms period (tRFI=3.9us).

Note; Currently the periodic Self-Refresh interval is hard coded within the DRAM to a specific value. There is a migration plan to support higher temperature Self-Refresh entry via the control of EMR(2) bit A7. However, since Self-Refresh control function is a migrated process. For our DDR2 module user, it is imperative to check SPD Byte 49 Bit 0 to ensure the DRAM parts support higher than 85°C case temperature Self-Refresh entry.

- 1) if SPD Byte 49 Bit 0 is a “0” means DRAM does not support Self-Refresh at higher than 85°C, then system have to ensure the DRAM is at or below 85°C case temperature before initiating Self-Refresh operation.
- 2) if SPD Byte 49 Bit 0 is a “1” means DRAM supports Self-Refresh at higher than 85°C case temperature, then system can use register bit A7 at EMR(2) control DRAM to operate at proper Self-Refresh rate for higher temperature. Please also refer to EMR(2) register definition section and DDR2 DIMM SPD definition for details.

**Table 10. Operating temperature condition**

## 4. AC & DC Operating Conditions

### 4.1 DC Operation Conditions

#### 4.1.1 Recommended DC Operating Conditions (SSTL\_1.8)

Symbol	Parameter	Rating			Units	Notes
		Min.	Typ.	Max.		
VDD	Supply Voltage	1.7	1.8	1.9	V	1
VDDL	Supply Voltage for DLL	1.7	1.8	1.9	V	5
VDDQ	Supply Voltage for Output	1.7	1.8	1.9	V	1,5
VREF	Input Reference Voltage	0.49*VDDQ	0.50*VDDQ	0.51*VDDQ	mV	2,3
VTT	Termination Voltage	VREF-0.04	VREF	VREF+0.04	V	4

1. There is no specific device VDD supply voltage requirement SSTL-1.8 compliance. However under all conditions VDDQ must be less than or equal to VDD.  
 2. The value of VREF may be selected by the user to provide optimum noise margin in the system. Typically the value of VREF is expected to be about 0.5 x VDDQ of the transmitting device and VREF is expected to track variations in VDDQ.  
 3. Peak to peak ac noise on VREF may not exceed +/-2% VREF (dc).  
 4. VTT of transmitting device must track VREF of receiving device.  
 5. VDDQ tracks with VDD, VDDL tracks with VDD. AC parameters are measured with VDD, VDDQ and VDDL tied together.

**Table 11. REcommended DC operating conditions (SSTL\_1.8)**

#### 4.1.2 ODT DC electrical characteristics

PARAMETER/CONDITION	SYMBOL	MIN	NOM	MAX	UNITS	NOTES
Rtt effective impedance value for EMRS(A6,A2)=0,1; 75 Ω	Rtt1(eff)	60	75	90	Ω	1
Rtt effective impedance value for EMRS(A6,A2)=1,0; 150 Ω	Rtt2(eff)	120	150	180	Ω	1
Rtt effective impedance value for EMRS(A6,A2)=1,1; 50 Ω	Rtt2(eff)	40	50	60	Ω	1,2
Deviation of Vm with respect to VDDQ/2	ΔVM	-6		+6	%	1

Note

1. Test condition for Rtt measurements
2. Optional for DDR2-400/533/667, mandatory for DDR2-800.

Measurement Definition for Rtt(eff): Apply  $V_{IH}(ac)$  and  $V_{IL}(ac)$  to test pin separately, then measure current  $I(V_{IH}(ac))$  and  $I(V_{IL}(ac))$  respectively.  $V_{IH}(ac)$ ,  $V_{IL}(ac)$ , and VDDQ values defined in SSTL\_18

$$R_{tt}(eff) = \frac{V_{IH}(ac) - V_{IL}(ac)}{I(V_{IH}(ac)) - I(V_{IL}(ac))}$$

Measurement Definition for VM : Measurement Voltage at test pin(mid point) with no load.

$$\Delta VM = \frac{2 \times V_m}{VDDQ} - 1 \times 100\%$$

**Table 12. PDDT DC electrical characteristics**

## 4.2 DC & AC Logic Input Levels

### 4.2.1 Input DC Logic Level

Symbol	Parameter	Min.	Max.	Units	Notes
$V_{IH}(dc)$	dc input logic HIGH	$V_{REF} + 0.125$	$V_{DDQ} + 0.3$	V	
$V_{IL}(dc)$	dc input logic LOW	- 0.3	$V_{REF} - 0.125$	V	

**Table 13. Input DC logic level**

### 4.2.2 Input AC Logic Level

Symbol	Parameter	DDR2-400, DDR2-533		DDR2-667, DDR2-800		Units	Notes
		Min.	Max.	Min.	Max.		
$V_{IH}(ac)$	ac input logic HIGH	$V_{REF} + 0.250$	$V_{DDQ} + V_{peak}$	$V_{REF} + 0.200$	$V_{DDQ} + V_{peak}$	V	1
$V_{IL}(ac)$	ac input logic LOW	$V_{SSQ} - V_{peak}$	$V_{REF} - 0.250$	$V_{SSQ} - V_{peak}$	$V_{REF} - 0.200$	V	1

Notes:

1. Refer to Overshoot/undershoot specifications for  $V_{peak}$  value: maximum peak amplitude allowed for overshoot and undershoot.

**Table 14. Input AC logic level**

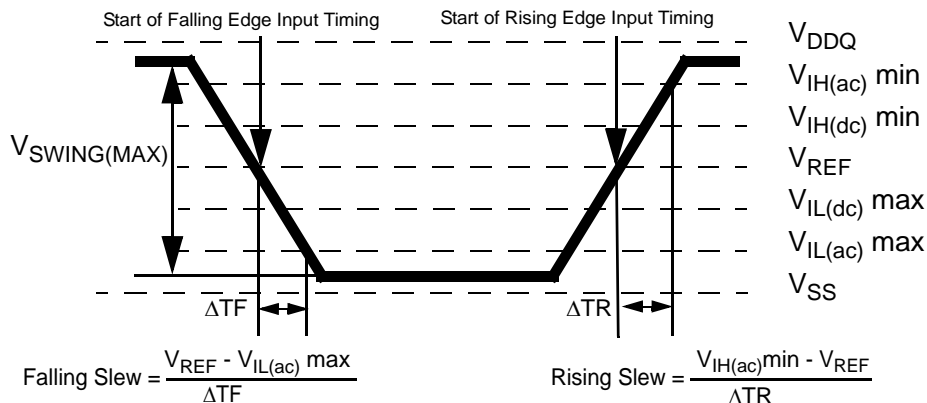
### 4.2.3 AC Input Test Conditions

Symbol	Condition	Value	Units	Notes
$V_{REF}$	Input reference voltage	$0.5 * V_{DDQ}$	V	1
$V_{SWING(MAX)}$	Input signal maximum peak to peak swing	1.0	V	1
SLEW	Input signal minimum slew rate	1.0	V/ns	2, 3

Notes:

1. Input waveform timing is referenced to the input signal crossing through the  $V_{REF}$  level applied to the device under test.
2. The input signal minimum slew rate is to be maintained over the range from  $V_{REF}$  max to  $V_{IH}(ac)$  min for rising edges and the range from  $V_{REF}$  min to  $V_{IL}(ac)$  max for falling edges as shown in the below figure.
3. AC timings are referenced with input waveforms switching from  $V_{IL}(ac)$  to  $V_{IH}(ac)$  on the positive transitions and  $V_{IH}(ac)$  to  $V_{IL}(ac)$  on the negative transitions.

**Table 15. AC input test conditions**



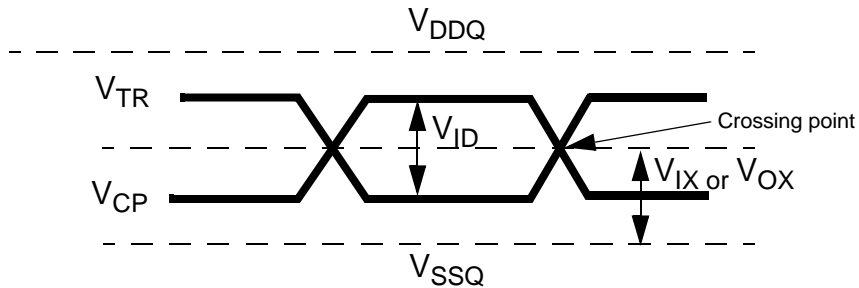
**Figure 57. AC input test signal waveform**

## 4.2.4 Differential Input AC logic Level

Symbol	Parameter	Min.	Max.	Units	Notes
$V_{ID(ac)}$	ac differential input voltage	0.5	VDDQ	V	1,3
$V_{IX(ac)}$	ac differential cross point voltage	$0.5 * VDDQ - 0.175$	$0.5 * VDDQ + 0.175$	V	2

- $V_{ID(DC)}$  specifies the allowable DC execution of each input of differential pair such as CK,  $\overline{CK}$ , DQS,  $\overline{DQS}$ , LDQS,  $\overline{LDQS}$ , UDQS and  $\overline{UDQS}$ .
- $V_{ID(DC)}$  specifies the input differential voltage  $|V_{TR} - V_{CP}|$  required for switching, where  $V_{TR}$  is the true input (such as CK, DQS, LDQS or UDQS) level and  $V_{CP}$  is the complementary input (such as  $\overline{CK}$ ,  $\overline{DQS}$ ,  $\overline{LDQS}$  or  $\overline{UDQS}$ ) level. The minimum value is equal to  $V_{IH(DC)} - V_{IL(DC)}$ .
- Refer to Overshoot/undershoot specifications for  $V_{peak}$  value: maximum peak amplitude allowed for overshoot and undershoot.

**Table 15. AC input test conditions**



Notes:

- $V_{ID(AC)}$  specifies the input differential voltage  $|V_{TR} - V_{CP}|$  required for switching, where  $V_{TR}$  is the true input signal (such as CK, DQS, LDQS or UDQS) and  $V_{CP}$  is the complementary input signal (such as  $\overline{CK}$ ,  $\overline{DQS}$ ,  $\overline{LDQS}$  or  $\overline{UDQS}$ ). The minimum value is equal to  $V_{IH(AC)} - V_{IL(AC)}$ .
- The typical value of  $V_{IX(AC)}$  is expected to be about  $0.5 * VDDQ$  of the transmitting device and  $V_{IX(AC)}$  is expected to track variations in  $VDDQ$ .  $V_{IX(AC)}$  indicates the voltage at which differential input signals must cross.

**Figure 58. Differential signal levels**

## 4.2.5 Differential AC output parameters

Symbol	Parameter	Min.	Max.	Units	Notes
$V_{OX(ac)}$	ac differential cross point voltage	$0.5 * VDDQ - 0.125$	$0.5 * VDDQ + 0.125$	V	1

Notes:

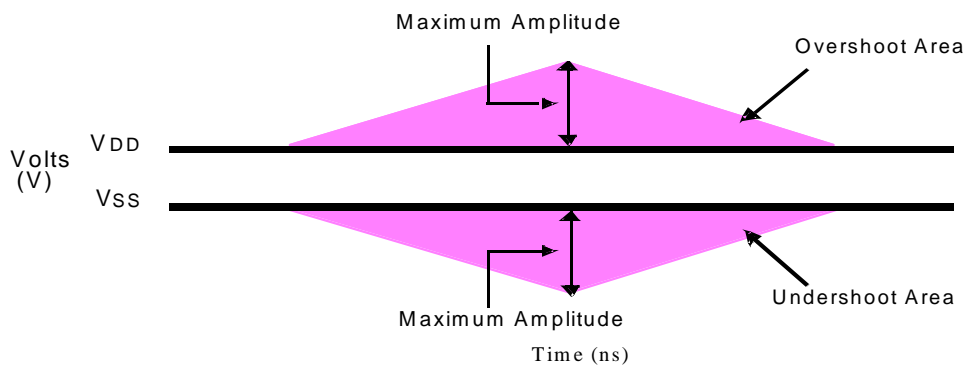
- The typical value of  $V_{OX(AC)}$  is expected to be about  $0.5 * VDDQ$  of the transmitting device and  $V_{OX(AC)}$  is expected to track variations in  $VDDQ$ .  $V_{OX(AC)}$  indicates the voltage at which differential output signals must cross.

**Table 16. Differential AC output parameters**

## 4.2.6 Overshoot/Undershoot Specification

Parameter	Specification			
	DDR2-400	DDR2-533	DDR2-667	DDR2-800
Maximum peak amplitude allowed for overshoot area (See Figure 1):	0.5V	0.5V	0.5V	0.5V
Maximum peak amplitude allowed for undershoot area (See Figure 1):	0.5V	0.5V	0.5V	0.5V
Maximum overshoot area above VDD (See Figure1).	1.33 V-ns	1.0 V-ns	0.8V-ns	0.66V-ns
Maximum undershoot area below VSS (See Figure 1).	1.33 V-ns	1.0 V-ns	0.8V-ns	0.66V-ns

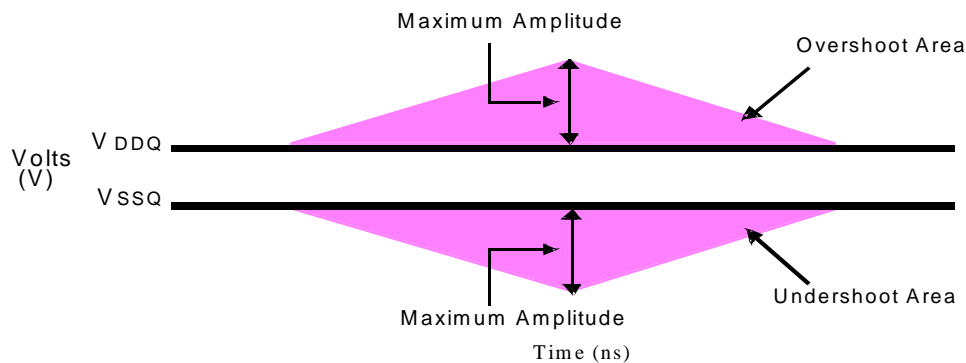
**Table 17. AC Overshoot/Undershoot Specification for Address and Control Pins:**  
**A0-A15, BA0-BA2,  $\overline{CS}$ ,  $\overline{RAS}$ ,  $\overline{CAS}$ ,  $\overline{WE}$ , CKE, ODT**



**Figure 59. AC overshoot and undershoot definition for address and control pins**

Parameter	Specification			
	DDR2-400	DDR2-533	DDR2-667	DDR2-800
Maximum peak amplitude allowed for overshoot area (See Figure 2):	0.5V	0.5V	0.5V	0.5V
Maximum peak amplitude allowed for undershoot area (See Figure 2):	0.5V	0.5V	0.5V	0.5V
Maximum overshoot area above VDDQ (See Figure 2).	0.38 V-ns	0.28 V-ns	0.23 V-ns	0.23 V-ns
Maximum undershoot area below VSSQ (See Figure 2).	0.38 V-ns	0.28 V-ns	0.23 V-ns	0.23 V-ns

**Table 18. AC Overshoot/Undershoot Specification for Clock, Data, Strobe, and Mask Pins:**  
**DQ, (U/L/R)DQS,  $\overline{(U/L/R)DQS}$ , DM, CK,  $\overline{CK}$**



**Figure 60. AC overshoot and undershoot definition for clock, data, strobe, and mask pins**

Power and ground clamps are required on the following input only pins:

1. BA0-BA2
2. A0-A15
3.  $\overline{\text{RAS}}$
4.  $\overline{\text{CAS}}$
5.  $\overline{\text{WE}}$
6.  $\overline{\text{CS}}$
7. ODT
8. CKE

Voltage across clamp(V)	Minimum Power Clamp Current (mA)	Minimum Ground Clamp Current (mA)
0.0	0	0
0.1	0	0
0.2	0	0
0.3	0	0
0.4	0	0
0.5	0	0
0.6	0	0
0.7	0	0
0.8	0.1	0.1
0.9	1.0	1.0
1.0	2.5	2.5
1.1	4.7	4.7
1.2	6.8	6.8
1.3	9.1	9.1
1.4	11.0	11.0
1.5	13.5	13.5
1.6	16.0	16.0
1.7	18.2	18.2
1.8	21.0	21.0

**Table 19. V-I Characteristics table for input only pins with clamps**

## 4.3 Output Buffer Characteristics

### 4.3.1 Output AC Test Conditions

Symbol	Parameter	SSTL_18 Class II	Units	Notes
$V_{OTR}$	Output Timing Measurement Reference Level	$0.5 * V_{DDQ}$	V	1
1. The VDDQ of the device under test is referenced.				

**Table 20. Output AC test conditions**

### 4.3.2 Output DC Current Drive

Symbol	Parameter	SSTL_18	Units	Notes
$I_{OH(dc)}$	Output Minimum Source DC Current	- 13.4	mA	1, 3, 4
$I_{OL(dc)}$	Output Minimum Sink DC Current	13.4	mA	2, 3, 4
<ol style="list-style-type: none"> <li><math>V_{DDQ} = 1.7\text{ V}</math>; <math>V_{OUT} = 1420\text{ mV}</math>. <math>(V_{OUT} - V_{DDQ})/I_{OH}</math> must be less than <math>21\ \Omega</math> for values of <math>V_{OUT}</math> between <math>V_{DDQ}</math> and <math>V_{DDQ} - 280\text{ mV}</math>.</li> <li><math>V_{DDQ} = 1.7\text{ V}</math>; <math>V_{OUT} = 280\text{ mV}</math>. <math>V_{OUT}/I_{OL}</math> must be less than <math>21\ \Omega</math> for values of <math>V_{OUT}</math> between <math>0\text{ V}</math> and <math>280\text{ mV}</math>.</li> <li>The dc value of <math>V_{REF}</math> applied to the receiving device is set to <math>V_{TT}</math></li> <li>The values of <math>I_{OH(dc)}</math> and <math>I_{OL(dc)}</math> are based on the conditions given in Notes 1 and 2. They are used to test device drive current capability to ensure <math>V_{IH\ min}</math> plus a noise margin and <math>V_{IL\ max}</math> minus a noise margin are delivered to an SSTL_18 receiver. The actual current values are derived by shifting the desired driver operating point (see Section 3.3) along a <math>21\ \Omega</math> load line to define a convenient driver current for measurement.</li> </ol>				

**Table 21. Output DC current drive**

### 4.3.3 OCD default characteristics

Description	Parameter	Min	Nom	Max	Unit	Notes
Output impedance		12.6	18	23.4	$\Omega$	1,2
Output impedance step size for OCD calibration		0		1.5	$\Omega$	6
Pull-up and pull-down mis-match		0		4	$\Omega$	1,2,3
Output slew rate	Sout	1.5	-	5	V/ns	1,4,5,6,7,8

Note:

1. Absolute Specifications ( $0^{\circ}\text{C} \leq T_{\text{CASE}} \leq +\text{tbd}^{\circ}\text{C}$ ;  $V_{\text{DD}} = +1.8\text{V} \pm 0.1\text{V}$ ,  $V_{\text{DDQ}} = +1.8\text{V} \pm 0.1\text{V}$ )
- 2 Impedance measurement condition for output source dc current:  $V_{\text{DDQ}} = 1.7\text{V}$ ;  $V_{\text{OUT}} = 1420\text{mV}$ ;  $(V_{\text{OUT}} - V_{\text{DDQ}})/I_{\text{oh}}$  must be less than  $23.4 \Omega$  for values of  $V_{\text{OUT}}$  between  $V_{\text{DDQ}}$  and  $V_{\text{DDQ}} - 280\text{mV}$ . Impedance measurement condition for output sink dc current:  $V_{\text{DDQ}} = 1.7\text{V}$ ;  $V_{\text{OUT}} = 280\text{mV}$ ;  $V_{\text{OUT}}/I_{\text{ol}}$  must be less than  $23.4 \Omega$  for values of  $V_{\text{OUT}}$  between  $0\text{V}$  and  $280\text{mV}$ .
3. Mismatch is absolute value between pull-up and pull-down, both are measured at same temperature and voltage.
4. Slew rate measured from  $v_{\text{il}}(\text{ac})$  to  $v_{\text{ih}}(\text{ac})$ .
5. The absolute value of the slew rate as measured from DC to DC is equal to or greater than the slew rate as measured from AC to AC. This is guaranteed by design and characterization.
6. This represents the step size when the OCD is near  $18 \Omega$  at nominal conditions across all process corners/variations and represents only the DRAM uncertainty. A  $0 \Omega$  value (no calibration) can only be achieved if the OCD impedance is  $18 \Omega \pm 0.75 \Omega$  under nominal conditions.
7. DRAM output slew rate specification applies to 400MT/s & 533MT/s speed bins.
8. Timing skew due to DRAM output slew rate mis-match between  $\text{DQS} / \overline{\text{DQS}}$  and associated DQs is included in  $t_{\text{DQSQ}}$  and  $t_{\text{QHS}}$  specification.
9. DDR2 SDRAM output slew rate test load is defined in General Note 3 of the AC Timing specification Table in Hynix DDR2 SDRAM component datasheet.

**Table 22. Output DC current drive**

### 4.4 Default Output V-I characteristics

DDR2 SDRAM output driver characteristics are defined for full strength default operation as selected by the EMR1 bits A7-A9 = '111'. The above Figures show the driver characteristics graphically, and tables show the same data in tabular format suitable for input into simulation tools.

#### Default Output Driver Characteristic Curves Notes:

- 1) The full variation in driver current from minimum to maximum process, temperature and voltage will lie within the outer bounding lines of the V-I curve of the following related Figures.
- 2) It is recommended that the "typical" IBIS V-I curve lie within the inner bounding lines of the V-I curves of the following related Figures.

## 4.4.1 Full Strength Default Pulldown Driver Characteristics

Voltage (V)	Pulldown Current (mA)			
	Minimum (23.4 Ohms)	Nominal Default Low (18 ohms)	Nominal Default High (18 ohms)	Maximum (12.6 Ohms)
0.2	8.5	11.3	11.8	15.9
0.3	12.1	16.5	16.8	23.8
0.4	14.7	21.2	22.1	31.8
0.5	16.4	25.0	27.6	39.7
0.6	17.8	28.3	32.4	47.7
0.7	18.6	30.9	36.9	55.0
0.8	19.0	33.0	40.9	62.3
0.9	19.3	34.5	44.6	69.4
1.0	19.7	35.5	47.7	75.3
1.1	19.9	36.1	50.4	80.5
1.2	20.0	36.6	52.6	84.6
1.3	20.1	36.9	54.2	87.7
1.4	20.2	37.1	55.9	90.8
1.5	20.3	37.4	57.1	92.9
1.6	20.4	37.6	58.4	94.9
1.7	20.6	37.7	59.6	97.0
1.8		37.9	60.9	99.1
1.9				101.1

Table 23. Full strength default pulldown driver characteristics

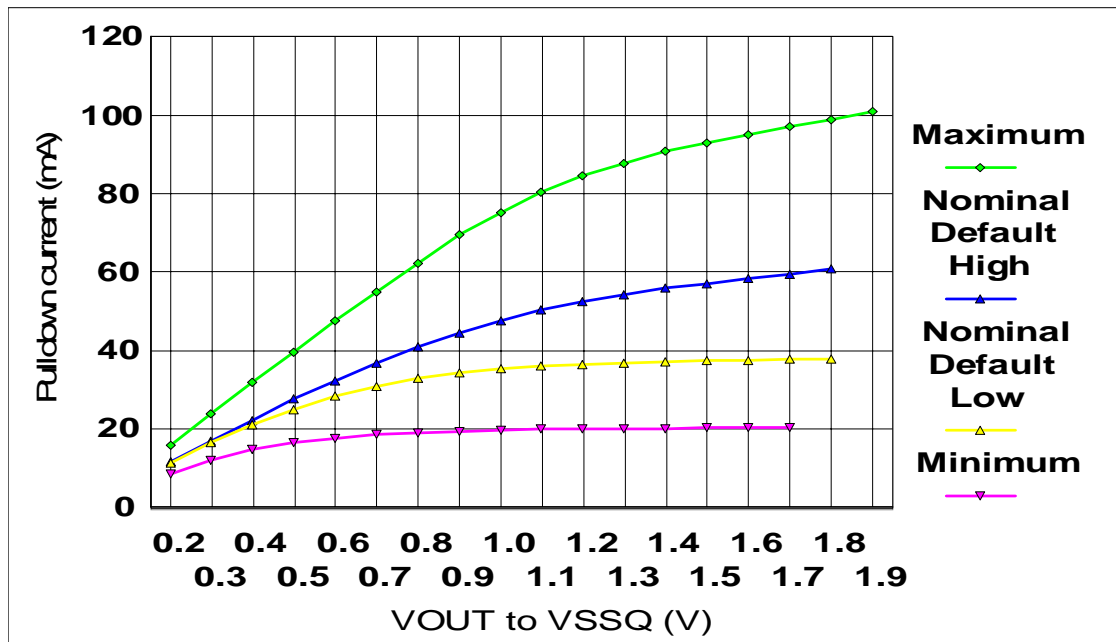


Figure 61. DDR2 default pulldown characteristics for full strength driver

## 4.4.2 Full Strength Default Pullup Driver Characteristics

Voltage (V)	Pullup Current (mA)			
	Minimum (23.4 Ohms)	Nominal Default Low (18 ohms)	Nominal Default High (18 ohms)	Maximum (12.6 Ohms)
0.2	-8.5	-11.1	-11.8	-15.9
0.3	-12.1	-16.0	-17.0	-23.8
0.4	-14.7	-20.3	-22.2	-31.8
0.5	-16.4	-24.0	-27.5	-39.7
0.6	-17.8	-27.2	-32.4	-47.7
0.7	-18.6	-29.8	-36.9	-55.0
0.8	-19.0	-31.9	-40.8	-62.3
0.9	-19.3	-33.4	-44.5	-69.4
1.0	-19.7	-34.6	-47.7	-75.3
1.1	-19.9	-35.5	-50.4	-80.5
1.2	-20.0	-36.2	-52.5	-84.6
1.3	-20.1	-36.8	-54.2	-87.7
1.4	-20.2	-37.2	-55.9	-90.8
1.5	-20.3	-37.7	-57.1	-92.9
1.6	-20.4	-38.0	-58.4	-94.9
1.7	-20.6	-38.4	-59.6	-97.0
1.8		-38.6	-60.8	-99.1
1.9				-101.1

Table 24. Default pullup characteristics for full strength output driver

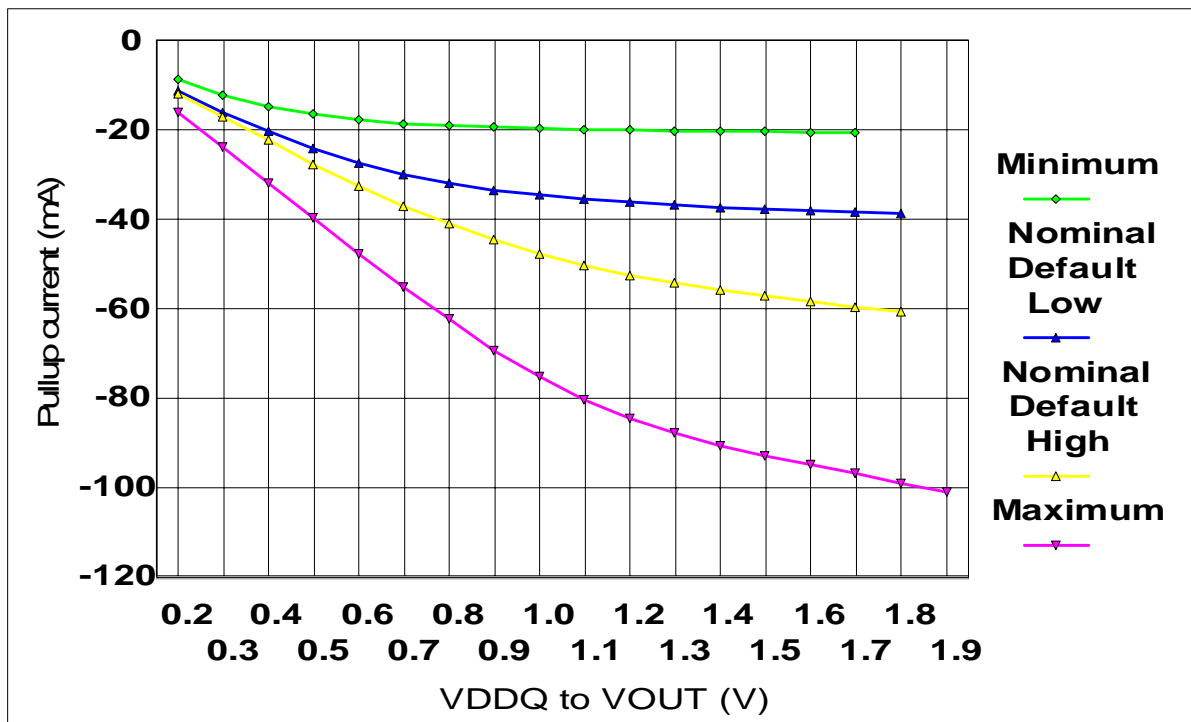


Figure 62. DDR2 default pullup characteristics for full strength driver

### 4.4.3 Calibrated Output Driver V-I Characteristics

DDR2 SDRAM output driver characteristics are defined for full strength calibrated operation as selected by the procedure in OCD impedance adjustment. The below Tables show the data in tabular format suitable for input into simulation tools. The nominal points represent a device at exactly 18 Ω. The nominal low and nominal high values represent the range that can be achieved with a maximum 1.5 Ω step size with no calibration error at the exact nominal conditions only (i.e. perfect calibration procedure, 1.5 Ω maximum step size guaranteed by specification). Real system calibration error needs to be added to these values. It must be understood that these V-I curves as represented here or in supplier IBIS models need to be adjusted to a wider range as a result of any system calibration error. Since this is a system specific phenomena, it cannot be quantified here. The values in the calibrated tables represent just the DRAM portion of uncertainty while looking at one DQ only. If the calibration procedure is used, it is possible to cause the device to operate outside the bounds of the default device characteristics tables and figures. In such a situation, the timing parameters in the specification cannot be guaranteed. It is solely up to the system application to ensure that the device is calibrated between the minimum and maximum default values at all times. If this can't be guaranteed by the system calibration procedure, re-calibration policy, and uncertainty with DQ to DQ variation, then it is recommended that only the default values be used. The nominal maximum and minimum values represent the change in impedance from nominal low and high as a result of voltage and temperature change from the nominal condition to the maximum and minimum conditions. If calibrated at an extreme condition, the amount of variation could be as much as from the nominal minimum to the nominal maximum or vice versa. The driver characteristics evaluation conditions are:

- Nominal 25 °C (T case), VDDQ = 1.8 V, typical process
- Nominal Low and Nominal High 25 °C (T case), VDDQ = 1.8 V, any process
- Nominal Minimum TBD °C (T case), VDDQ = 1.7 V, any process
- Nominal Maximum 0 °C (T case), VDDQ = 1.9 V, any process

Voltage (V)	Calibrated Pulldown Current (mA)				
	Nominal Minimum (21 ohms)	Nominal Low (18.75 ohms)	Nominal (18 ohms)	Nominal High (17.25 ohms)	Nominal Maximum (15 ohms)
0.2	9.5	10.7	11.5	11.8	13.3
0.3	14.3	16.0	16.6	17.4	20.0
0.4	18.7	21.0	21.6	23.0	27.0

**Table 25. Full strength calibrated pulldown driver characteristics**

Voltage (V)	Calibrated Pullup Current (mA)				
	Nominal Minimum (21 ohms)	Nominal Low (18.75 ohms)	Nominal (18 ohms)	Nominal High (17.25 ohms)	Nominal Maximum (15 ohms)
0.2	-9.5	-10.7	-11.4	-11.8	-13.3
0.3	-14.3	-16.0	-16.5	-17.4	-20.0
0.4	-18.7	-21.0	-21.2	-23.0	-27.0

**Table 26. Full strength calibrated pullup driver characteristics**