

**256Mb(16Mx16)**  
**DDR2 SDRAM**  
**HY5PS561621BFP**

## Revision History

Revision No.	History	Draft Date	Remark
0.0	Initial Graphics Version Release	Jan. 2007	Preliminary
0.1	Inserted the fixed speed bin and revised typos	Jan. 2007	Preliminary
0.2	Added PKG information on page 78	Feb. 2007	Preliminary
0.3	Inserted the IDD value	Mar. 2007	Preliminary
1.0	Revised tWR=15ns, tRCD=15ns and tRP=15ns at page 74	Apr. 2007	

**Note)** The HY5PS561621BFP data sheet follows all of JEDEC DDR2 standard.

## Contents

### 1. Description

- 1.1 Device Features and Ordering Information
  - 1.1.1 Key Features
  - 1.1.2 Ordering Information
- 1.2 16Mx16 DDR2 Pin Configuration
- 1.3 Pin Description

### 2. Functional Description

- 2.1 Simplified State Diagram
- 2.2 Functional Block Diagram(16M × 16)
- 2.3 Basic Function & Operation of DDR2 SDRAM
  - 2.3.1 Power up and Initialization
  - 2.3.2 Programming the Mode and Extended Mode Registers
    - 2.3.2.1 DDR2 SDRAM Mode Register Set(MRS)
    - 2.3.2.2 DDR2 SDRAM Extended Mode Register Set
    - 2.3.2.3 Off-Chip Driver(OCD) Impedance Adjustment
    - 2.3.2.4 ODT(On Die Termination)
- 2.4 Bank Activate Command
- 2.5 Read and Write Command
  - 2.5.1 Posted CAS
  - 2.5.2 Burst Mode Operation
  - 2.5.3 Burst Read Command
  - 2.5.4 Burst Write Operation
  - 2.5.5 Write Data Mask
- 2.6 Precharge Operation
- 2.7 Auto Precharge Operation
- 2.8 Refresh Commands
  - 2.8.1 Auto Refresh Command
  - 2.8.2 Self Refresh Command
- 2.9 Power Down
- 2.10 Asynchronous CKE Low Event
- 2.11 No Operation Command
- 2.12 Deselect Command

### 3. Truth Tables

- 3.1 Command Truth Table
- 3.2 Clock Enable(CKE) Truth Table for Synchronous Transistors
- 3.3 Data Mask Truth Table

### 4. Operating Conditions

- 4.1 Absolute Maximum DC Ratings
- 4.2 Operating Temperature Condition

## 5. AC & DC Operating Conditions

### 5.1 DC Operation Conditions

#### 5.1.1 Recommended DC Operating Conditions(SSTL\_1.8)

#### 5.1.2 ODT DC Electrical Characteristics

### 5.2 DC & AC Logic Input Levels

#### 5.2.1 Input DC Logic Level

#### 5.2.2 Input AC Logic Level

#### 5.2.3 AC Input Test Conditions

#### 5.2.4 Differential Input AC Logic Level

#### 5.2.5 Differential AC output parameters

#### 5.2.6 Overshoot / Undershoot Specification

### 5.3 Output Buffer Levels

#### 5.3.1 Output AC Test Conditions

#### 5.3.2 Output DC Current Drive

#### 5.3.3 OCD default characteristics

### 5.4 Default Output V-I Characteristics

#### 5.4.1 Full Strength Default Pulldown Driver Characteristics

#### 5.4.2 Full Strength Default Pullup Driver Characteristics

#### 5.4.3 Calibrated Output Driver V-I Characteristics

### 5.5 Input/Output Capacitance

## 6. IDD Specifications & Measurement Conditions

## 7. AC Timing Specifications

### 7.1 Timing Parameters by Speed Grade

### 7.2 General Notes for all AC Parameters

### 7.3 Specific Notes for dedicated AC parameters.

## 8 Package Dimension(x16)

# 1. Description

## 1.1 Device Features & Ordering Information

### 1.1.1 Key Feature

- 1.8V VDD/VDDQ wide range max power supply supports(500/450/400/350MHz)
- All inputs and outputs are compatible with SSTL\_18 interface
- Fully differential clock inputs (CK, /CK) operation
- Double data rate interface:two data transfers per clock cycle(tCK)
- Source synchronous-data transaction aligned to bidirectional data strobe (DQS,  $\overline{DQS}$ )
- Differential Data Strobe ( $\overline{DQS}$ , DQS)
- Data outputs on DQS,  $\overline{DQS}$  edges when read (edged DQ)
- Data inputs on DQS centers when write(centered DQ)
- On chip DLL align DQ, DQS and  $\overline{DQS}$  transition with CK transition
- DM mask write data-in at the both rising and falling edges of the data strobe
- All addresses and control inputs except data, data strobes and data masks latched on the rising edges of the clock
- Programmable CAS latency 4, 5, 6 and 7 supported
- Programmable additive latency 0, 1, 2, 3, 4, 5 supported
- Programmable burst length 4/8 with both nibble sequential and interleave mode
- Internal four bank operations with single pulsed RAS
- Auto refresh and self refresh supported
- tRAS lockout supported
- 8K refresh cycles /64ms
- JEDEC standard 84ball FBGA(x16)
- Full strength driver option controlled by EMRS
- On Die Termination supported
- Off Chip Driver Impedance Adjustment supported
- Partial Array Self Refresh supported
- High Temperature Self Refresh rate supported

### 1.1.2 Ordering Information

Part No.	Power Supply	Clock Frequency	Max Data Rate	Interface	Package
HY5PS561621BFP-2L	VDD/VDDQ=1.8V	500MHz	1000Mbps/pin	SSTL_18	84Ball FBGA
HY5PS561621BFP-22		450MHz	900Mbps/pin		
HY5PS561621BFP-25		400MHz	800Mbps/pin		
HY5PS561621BFP-28		350MHz	700Mbps/pin		

**Note)**

Hynix supports Lead free parts for each speed grade with same specification, except Lead free materials. We'll add "P" character after "F" for Lead free product. For example, the part number of 350MHz Lead free product is HY5PS561621BFP-28.

## 1.2 16Mx16 DDR2 Pin Configuration

1	2	3		7	8	9
VDD	NC	VSS	A	VSSQ	$\overline{\text{UDQS}}$	VDDQ
DQ14	VSSQ	UDM	B	UDQS	VSSQ	DQ15
VDDQ	DQ9	VDDQ	C	VDDQ	DQ8	VDDQ
DQ12	VSSQ	DQ11	D	DQ10	VSSQ	DQ13
VDD	NC	VSS	E	VSSQ	$\overline{\text{LDQS}}$	VDDQ
DQ6	VSSQ	LDM	F	LDQS	VSSQ	DQ7
VDDQ	DQ1	VDDQ	G	VDDQ	DQ0	VDDQ
DQ4	VSSQ	DQ3	H	DQ2	VSSQ	DQ5
VDDL	VREF	VSS	J	VSSDL	CK	VDD
	CKE	$\overline{\text{WE}}$	K	$\overline{\text{RAS}}$	$\overline{\text{CK}}$	ODT
NC	BA0	BA1	L	$\overline{\text{CAS}}$	$\overline{\text{CS}}$	
	A10	A1	M	A2	A0	VDD
VSS	A3	A5	N	A6	A4	
	A7	A9	P	A11	A8	VSS
VDD	A12	NC	R	NC	NC	

**ROW AND COLUMN ADDRESS TABLE**

ITEMS	16Mx16
# of Bank	4
Bank Address	BA0, BA1
Auto Precharge Flag	A10/AP
Row Address	A0 - A12
Column Address	A0-A8
Page size	1 KB

### 1.3 PIN DESCRIPTION

PIN	TYPE	DESCRIPTION
CK, $\overline{CK}$	Input	Clock: CK and $\overline{CK}$ are differential clock inputs. All address and control input signals are sampled on the crossing of the positive edge of CK and negative edge of $\overline{CK}$ . Output (read) data is referenced to the crossings of CK and $\overline{CK}$ (both directions of crossing).
$\overline{CKE}$	Input	Clock Enable: CKE HIGH activates, and CKE LOW deactivates internal clock signals, and device input buffers and output drivers. Taking CKE LOW provides PRECHARGE POWER DOWN and SELF REFRESH operation (all banks idle), or ACTIVE POWER DOWN (row ACTIVE in any bank). CKE is synchronous for POWER DOWN entry and exit, and for SELF REFRESH entry and exit. CKE must be maintained high throughout READ and WRITE accesses. Input buffers, excluding CK, $\overline{CK}$ , CKE and ODT are disabled during POWER DOWN. Input buffers, excluding CKE are disabled during SELF REFRESH. CKE is an SSTL_18 input, but will detect an LVCMOS LOW level after Vdd is applied.
$\overline{CS}$	Input	Chip Select : Enables or disables all inputs except CK, $\overline{CK}$ , CKE, DQS and DM. All commands are masked when $\overline{CS}$ is registered high. $\overline{CS}$ provides for external bank selection on systems with multiple banks. $\overline{CS}$ is considered part of the command code.
ODT	Input	On Die Termination Control : ODT enables on die termination resistance internal to the DDR2 SDRAM. When enabled, on die termination is only applied to DQ, LDQS, /LDQS, UDQS, /UDQS, LDM and UDM
RAS, $\overline{CAS}$ , $\overline{WE}$	Input	Command Inputs: RAS, $\overline{CAS}$ and $\overline{WE}$ (along with $\overline{CS}$ ) define the command being entered.
LDM, UDM	Input	Input Data Mask : DM is an input mask signal for write data. Input Data is masked when DM is sampled High coincident with that input data during a WRITE access. DM is sampled on both edges of DQS, Although DM pins are input only, the DM loading matches the DQ and DQS loading.
BA0, BA1	Input	Bank Address Inputs: BA0 and BA1 define to which bank an ACTIVE, Read, Write or PRECHARGE command is being applied. Bank address also determines if the mode register or extended mode register is to be accessed during a MRS or EMRS cycle.
A0 ~ A12	Input	Address Inputs: Provide the row address for ACTIVE commands, and the column address and AUTO PRECHARGE bit for READ/WRITE commands to select one location out of the memory array in the respective bank. A10 is sampled during a precharge command to determine whether the PRECHARGE applies to one bank (A10 LOW) or all banks (A10 HIGH). If only one bank is to be precharged, the bank is selected by BA0, BA1. The address inputs also provide the op code during MODE REGISTER SET commands.
DQ	Input/Output	Data input / output : Bi-directional data bus
(UDQS), ( $\overline{UDQS}$ ) (LDQS), ( $\overline{LDQS}$ )	Input/Output	Data Strobe : Output with read data, input with write data. Edge aligned with read data, centered in write data. For the x16, LDQS correspond to the data on DQ0~DQ7; UDQS corresponds to the data on DQ8~DQ15. The data strobes $\overline{LDQS}$ , $\overline{UDQS}$ may be used in single ended mode or paired with optional complementary signals LDQS, UDQS to provide differential pair signaling to the system during both reads and writes. An EMRS(1) control bit enables or disables all complementary data strobe signals.
NC		No Connect : No internal electrical connection is present.
VDDQ	Supply	DQ Ground
VDDL	Supply	DLL Power Supply
VSSDL	Supply	DLL Ground
VDD	Supply	Power Supply
VSS	Supply	Ground
VREF	Supply	Reference voltage for inputs for SSTL interface.

In this data sheet, "differential DQS signals" refers to any of the following with A10 = 0 of EMRS(1)

x16 LDQS/ $\overline{LDQS}$  and UDQS/ $\overline{UDQS}$

"single-ended DQS signals" refers to any of the following with A10 = 1 of EMRS(1)

x16 LDQS and UDQS

## 2. Functional Description

### 2.1 Simplified State Diagram

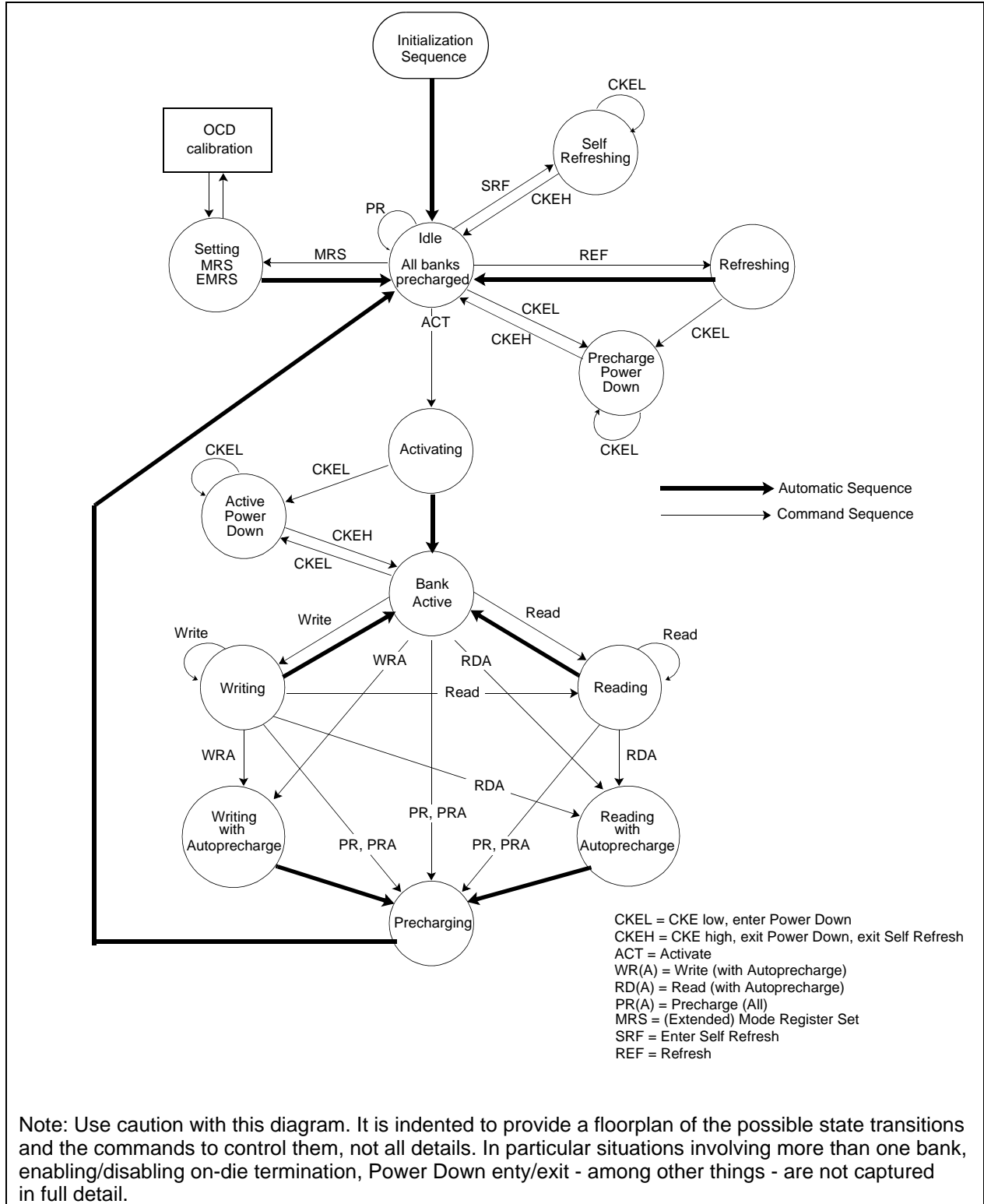

## 2.2 Functional Block Diagram (16Mx16)

4Banks x 4Mbit x 16 I/O DDR2 SDRAM

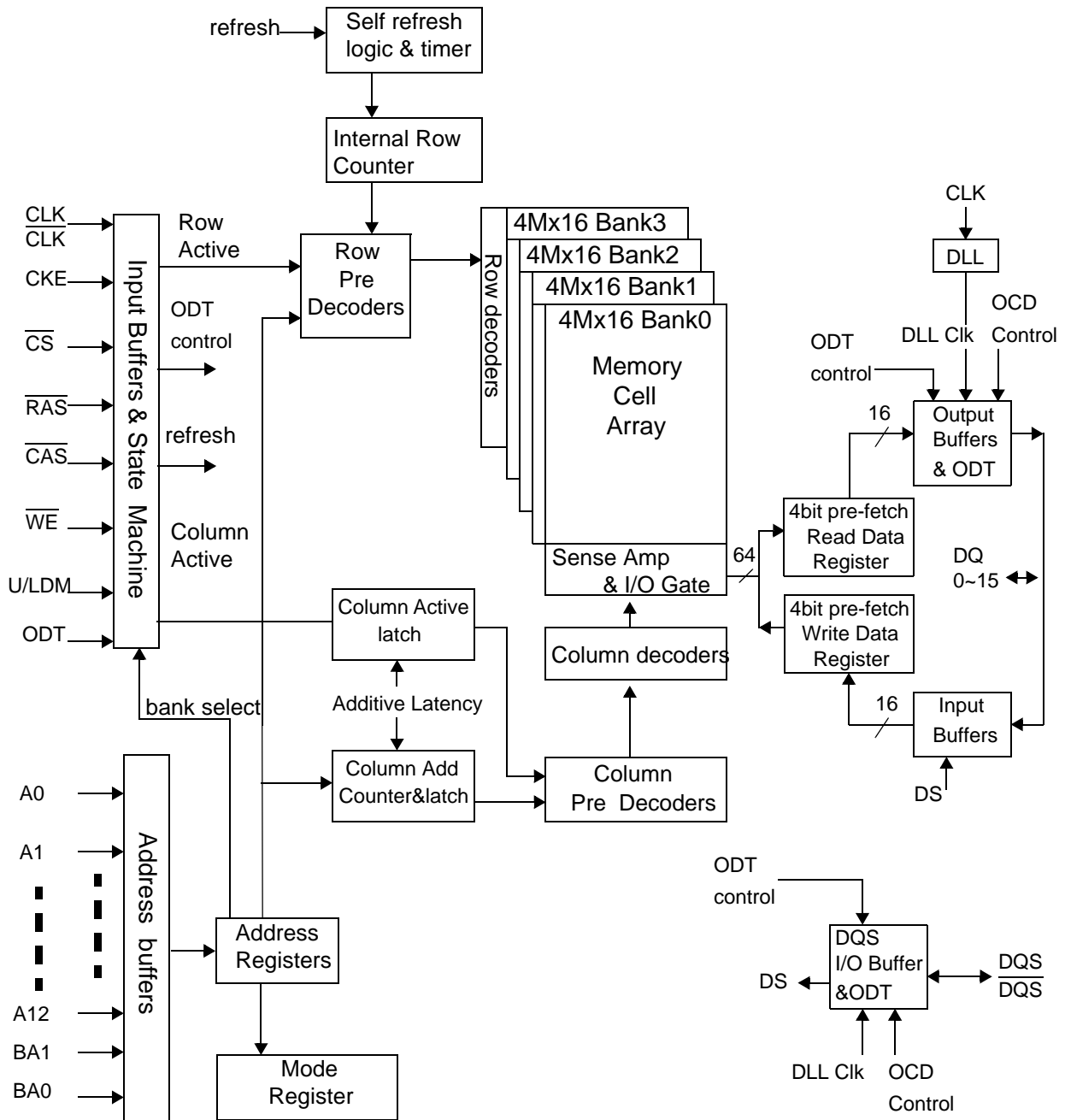

## 2.3 Basic Function & Operation of DDR2 SDRAM

Read and write accesses to the DDR2 SDRAM are burst oriented; accesses start at a selected location and continue for a burst length of four or eight in a programmed sequence. Accesses begin with the registration of an Active command, which is then followed by a Read or Write command. The address bits registered coincident with the active command are used to select the bank and row to be accessed (BA0-BA1 select the bank; A0-A12 select the row). The address bits registered coincident with the Read or Write command are used to select the starting column location for the burst access and to determine if the auto precharge command is to be issued.

Prior to normal operation, the DDR2 SDRAM must be initialized. The following sections provide detailed information covering device initialization, register definition, command descriptions and device operation.

### 2.3.1 Power up and Initialization

DDR2 SDRAMs must be powered up and initialized in a predefined manner. Operational procedures other than those specified may result in undefined operation.

#### Power-up and Initialization Sequence

The following sequence is required for POWER UP and Initialization.

1. Apply power and attempt to maintain CKE below  $0.2 \cdot V_{DDQ}$  and  $ODT^{*1}$  at a low state (all other inputs may be undefined.)

- VDD, VDDL and VDDQ are driven from a single power converter output, AND
- VTT is limited to 0.95 V max, AND
- Vref tracks  $V_{DDQ}/2$ .

or

- Apply VDD before or at the same time as VDDL.
- Apply VDDL before or at the same time as VDDQ.
- Apply VDDQ before or at the same time as VTT & Vref.

at least one of these two sets of conditions must be met.

2. Start clock and maintain stable condition.
3. For the minimum of 200 us after stable power and clock(CK,  $\overline{CK}$ ), then apply NOP or deselect & take CKE high.
4. Wait minimum of 400ns then issue precharge all command. NOP or deselect applied during 400ns period.
5. Issue EMRS(2) command. (To issue EMRS(2) command, provide "Low" to BA0, "High" to BA1.)<sup>\*2</sup>
6. Issue EMRS(3) command. (To issue EMRS(3) command, provide "High" to BA0 and BA1.)<sup>\*2</sup>
7. Issue EMRS to enable DLL. (To issue "DLL Enable" command, provide "Low" to A0, "High" to BA0 and "Low" to BA1.)
8. Issue a Mode Register Set command for "DLL reset".  
(To issue DLL reset command, provide "High" to A8 and "Low" to BA0-1.)
9. Issue precharge all command.
10. Issue 2 or more auto-refresh commands.
11. Issue a mode register set command with low to A8 to initialize device operation. (i.e. to program operating parameters without resetting the DLL.)
12. At least 200 clocks after step 8, execute OCD Calibration ( Off Chip Driver impedance adjustment ).  
If OCD calibration is not used, EMRS OCD Default command (A9=A8=A7=1) followed by EMRS OCD Calibration Mode Exit command (A9=A8=A7=0) must be issued with other operating parameters of EMRS.
13. The DDR2 SDRAM is now ready for normal operation.

\*1) To guarantee ODT off, VREF must be valid and a low level must be applied to the ODT pin.

\*2) Sequence 5 and 6 may be performed between 8 and 9.

### Initialization Sequence after Power Up

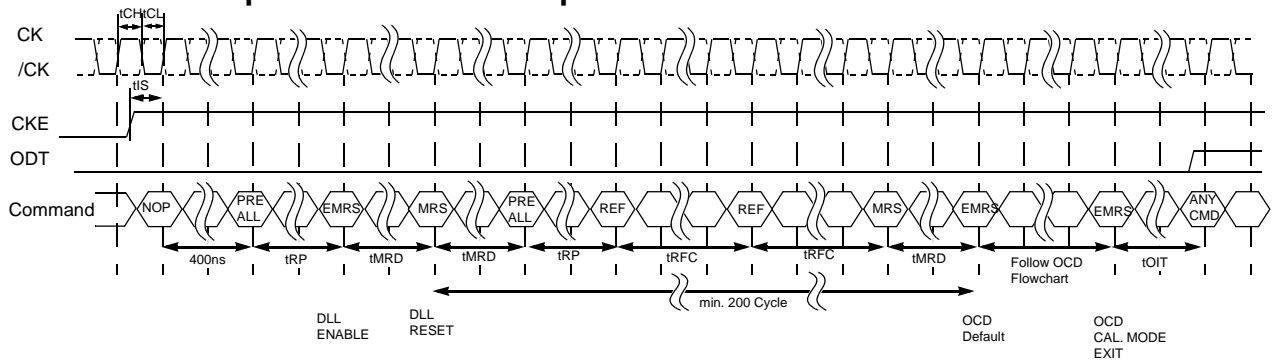

### 2.3.2 Programming the Mode and Extended Mode Registers

For application flexibility, burst length, burst type,  $\overline{\text{CAS}}$  latency, DLL reset function, write recovery time (tWR) are user defined variables and must be programmed with a Mode Register Set (MRS) command. Additionally, DLL disable function, driver impedance, additive CAS latency, ODT (On Die Termination), single-ended strobe, and OCD (off chip driver impedance adjustment) are also user defined variables and must be programmed with an Extended Mode Register Set (EMRS) command. Contents of the Mode Register (MR) or Extended Mode Registers (EMR(#)) can be altered by re-executing the MRS and EMRS Commands. If the user chooses to modify only a subset of the MRS or EMRS variables, all variables must be redefined when the MRS or EMRS commands are issued.

MRS, EMRS and Reset DLL do not affect array contents, which means reinitialization including those can be executed any time after power-up without affecting array contents.

### 2.3.2.1 DDR2 SDRAM Mode Register Set (MRS)

The mode register stores the data for controlling the various operating modes of DDR2 SDRAM. It controls  $\overline{\text{CAS}}$  latency, burst length, burst sequence, test mode, DLL reset, tWR and various vendor specific options to make DDR2 SDRAM useful for various applications. The default value of the mode register is not defined, therefore the mode register must be written after power-up for proper operation. The mode register is written by asserting low on  $\overline{\text{CS}}$ ,  $\overline{\text{RAS}}$ ,  $\overline{\text{CAS}}$ ,  $\overline{\text{WE}}$ , BA0 and BA1, while controlling the state of address pins A0 ~ A15. The DDR2 SDRAM should be in all bank precharge with CKE already high prior to writing into the mode register. The mode register set command cycle time (tMRD) is required to complete the write operation to the mode register. The mode register contents can be changed using the same command and clock cycle requirements during normal operation as long as all banks are in the precharge state. The mode register is divided into various fields depending on functionality. Burst length is defined by A0 ~ A2 with options of 4 and 8 bit burst lengths. The burst length decodes are compatible with DDR SDRAM. Burst address sequence type is defined by A3,  $\overline{\text{CAS}}$  latency is defined by A4 ~ A6. The DDR2 doesn't support half clock latency mode. A7 is used for test mode. A8 is used for DLL reset. A7 must be set to low for normal MRS operation. Write recovery time tWR is defined by A9 ~ A11. Refer to the table for specific codes.

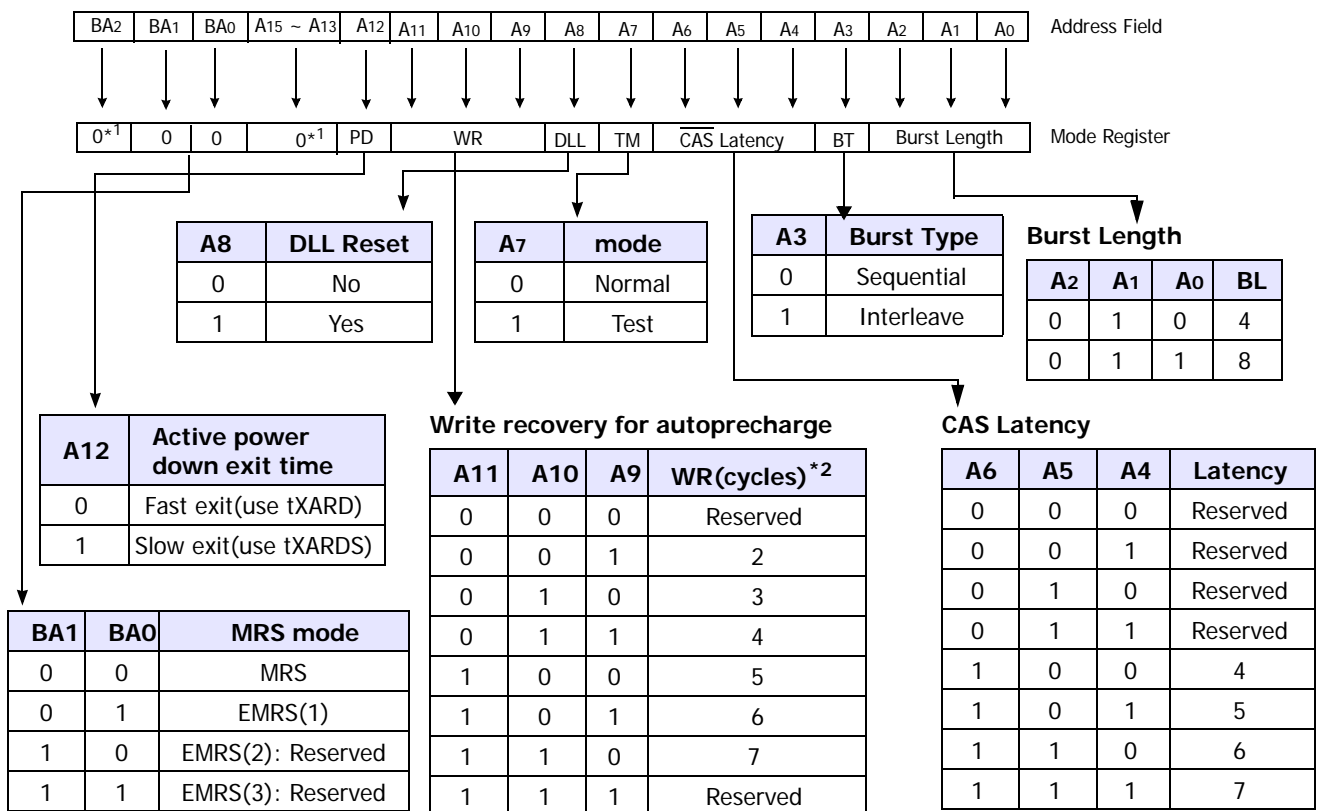

\*1: BA2 and A13~A15 are reserved for future use and must be programmed to 0 when setting the mode register. BA2 and A13~A15 are not used for 256Mb

\*2: WR(write recovery for autoprecharge) min is determined by tCK max and WR max is determined by tCK min. WR in clock cycles is calculated by dividing tWR (in ns) by tCK (in ns) and rounding up to the next integer (WR[cycles] = tWR(ns)/tCK(ns)). The mode register must be programmed to this value. This is also used with tRP to determine tDAL.

### 2.3.2.2 DDR2 SDRAM Extended Mode Register Set

#### EMRS(1)

The extended mode register(1) stores the data for enabling or disabling the DLL, output driver strength, additive latency, ODT,  $\overline{\text{DQS}}$  disable, OCD program, RDQS enable. The default value of the extended mode register(1) is not defined, therefore the extended mode register(1) must be written after power-up for proper operation. The extended mode register(1) is written by asserting low on  $\overline{\text{CS}}$ ,  $\overline{\text{RAS}}$ ,  $\overline{\text{CAS}}$ ,  $\overline{\text{WE}}$ , high on BA0 and low on BA1, while controlling the states of address pins A0 ~ A15. The DDR2 SDRAM should be in all bank precharge with CKE already high prior to writing into the extended mode register(1). The mode register set command cycle time (tMRD) must be satisfied to complete the write operation to the extended mode register(1). Mode register contents can be changed using the same command and clock cycle requirements during normal operation as long as all banks are in the precharge state. A0 is used for DLL enable or disable. A1 is used for enabling a half strength output driver. A3~A5 determines the additive latency, A7~A9 are used for OCD control, A10 is used for  $\overline{\text{DQS}}$  disable. A2 and A6 are used for ODT setting.

#### DLL Enable/Disable

The DLL must be enabled for normal operation. DLL enable is required during power up initialization, and upon returning to normal operation after having the DLL disabled. The DLL is automatically disabled when entering self refresh operation and is automatically re-enabled upon exit of self refresh operation. Any time the DLL is enabled (and subsequently reset), 200 clock cycles must occur before a Read command can be issued to allow time for the internal clock to be synchronized with the external clock. Failing to wait for synchronization to occur may result in a violation of the tAC or tDQCK parameters.

**EMRS(1) Programming**

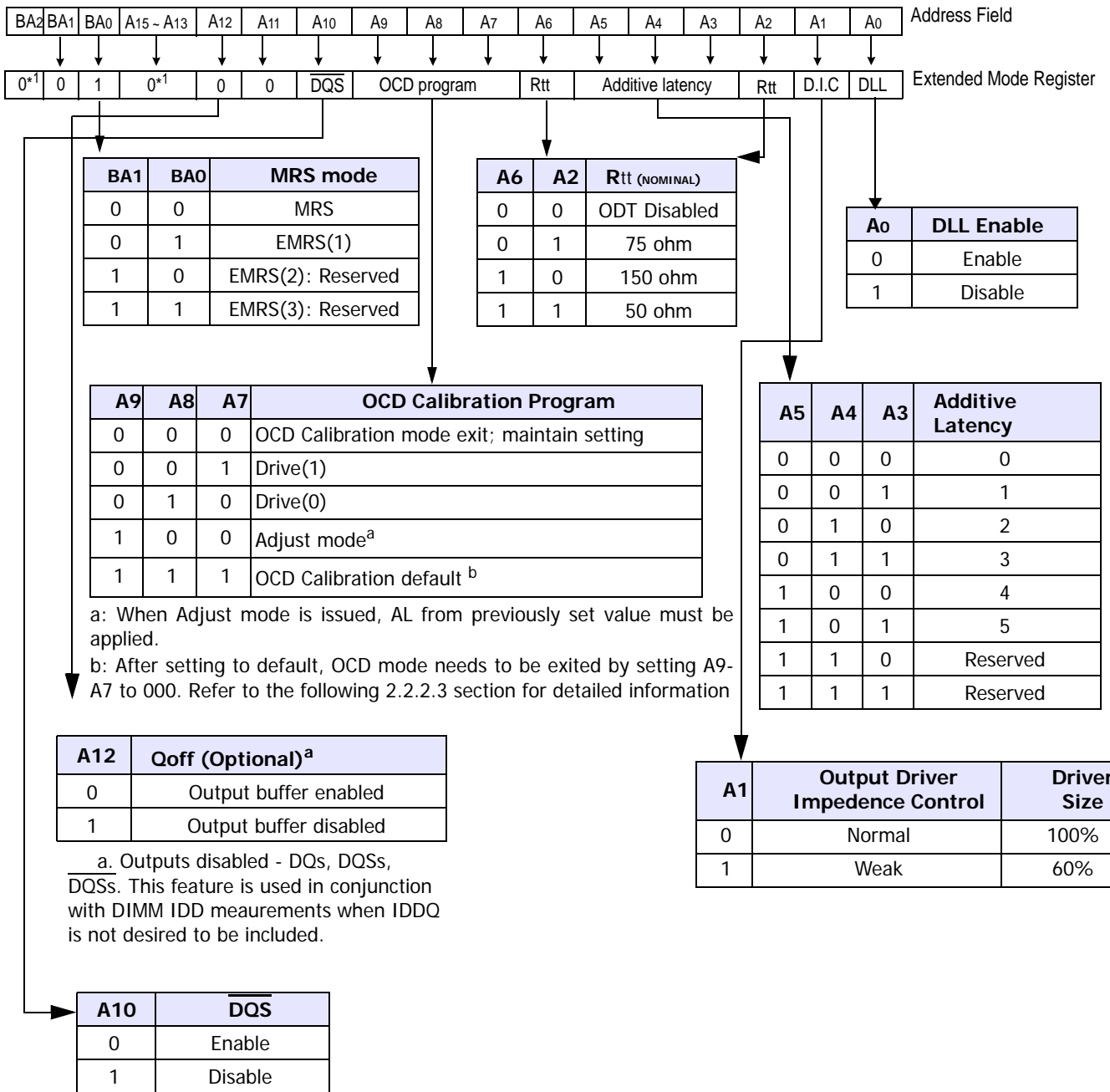

\*1 : BA2 and A13–A15 are reserved for future use and must be programmed to 0 when setting the mode register.

## EMRS(2)

The extended mode register(2) controls refresh related features. The default value of the extended mode register(2) is not defined, therefore the extended mode register(2) must be written after power-up for proper operation. The extended mode register(2) is written by asserting low on /CS,/RAS,/CAS,/WE, high on BA1 and low on BA0, while controlling the states of address pins A0–A15. The DDR2 SDRAM should be in all bank precharge with CKE already high prior to writing into the extended mode register(2). Mode register contents can be changed using the same command and clock cycle requirements during normal operation as long as all bank are in the precharge state.

### EMRS(2) Programming:

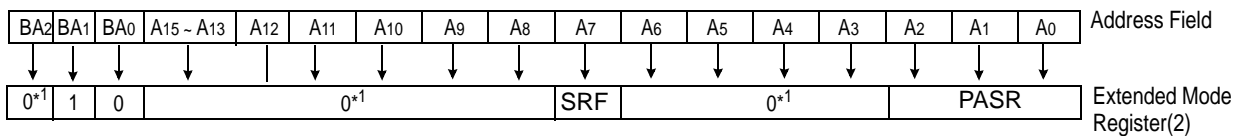

BA1	BA0	MRS mode
0	0	MRS
0	1	EMRS(1)
1	0	EMRS(2)
1	1	EMRS(3):Reserved

A7	High Temp Self-refresh Rate Enable
1	Enable
0	Disable

A2	A1	A0	Bank Refresh @ PASR
0	0	0	All Bank
0	0	1	Half Array (BA[1:0] = 00 & 01)
0	1	0	Quarter Array (BA[1:0] = 00)
0	1	1	Not defined
1	0	0	3/4 Quarter Array (BA[1:0] = 01, 10 & 11)
1	0	1	Half Array (BA[1:0] = 10 & 11)
1	1	0	Quarter Array (BA[1:0] = 11)
1	1	1	Not defined

\*1 : The rest bits in EMRS(2) is reserved for future use and all bits except A7, BA0 and BA1 must be programmed to 0 when setting the mode register during initialization.

Due to the migration natural, user needs to ensure the DRAM part supports higher than 85°... Tcase temperature self-refresh entry. JEDEC standard DDR2 SDRAM Module user can look at DDR2 SDRAM Module SPD fileld Byte 49 bit[0]. If the high temperature self-refresh mode is supported then controller can set the EMRS2 [A7] bit to enable the self-refresh rate in case of higher than 85°... temperature self-refresh operation. For the lose part user, please refer to the Hynix web site([www.hynix.com](http://www.hynix.com)) to check the high temperature self-refresh rate availability. In order to save power consumption, DDR2 DRAM has Partial Array Self Refresh (PASR) option. PASR includes 6 kinds of self refresh mode.

### EMRS(3) Programming: Reserved\*1

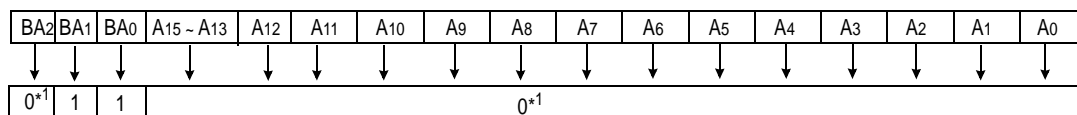

\*1 : EMRS(3) is reserved for future use and all bits except BA0 and BA1 must be programmed to 0 when setting the mode register during initialization.

### 2.3.2.3 Off-Chip Driver (OCD) Impedance Adjustment

DDR2 SDRAM supports driver calibration feature and the flow chart below is an example of sequence. Every calibration mode command should be followed by "OCD calibration mode exit" before any other command being issued. MRS should be set before entering OCD impedance adjustment and ODT (On Die Termination) should be carefully controlled depending on system environment.

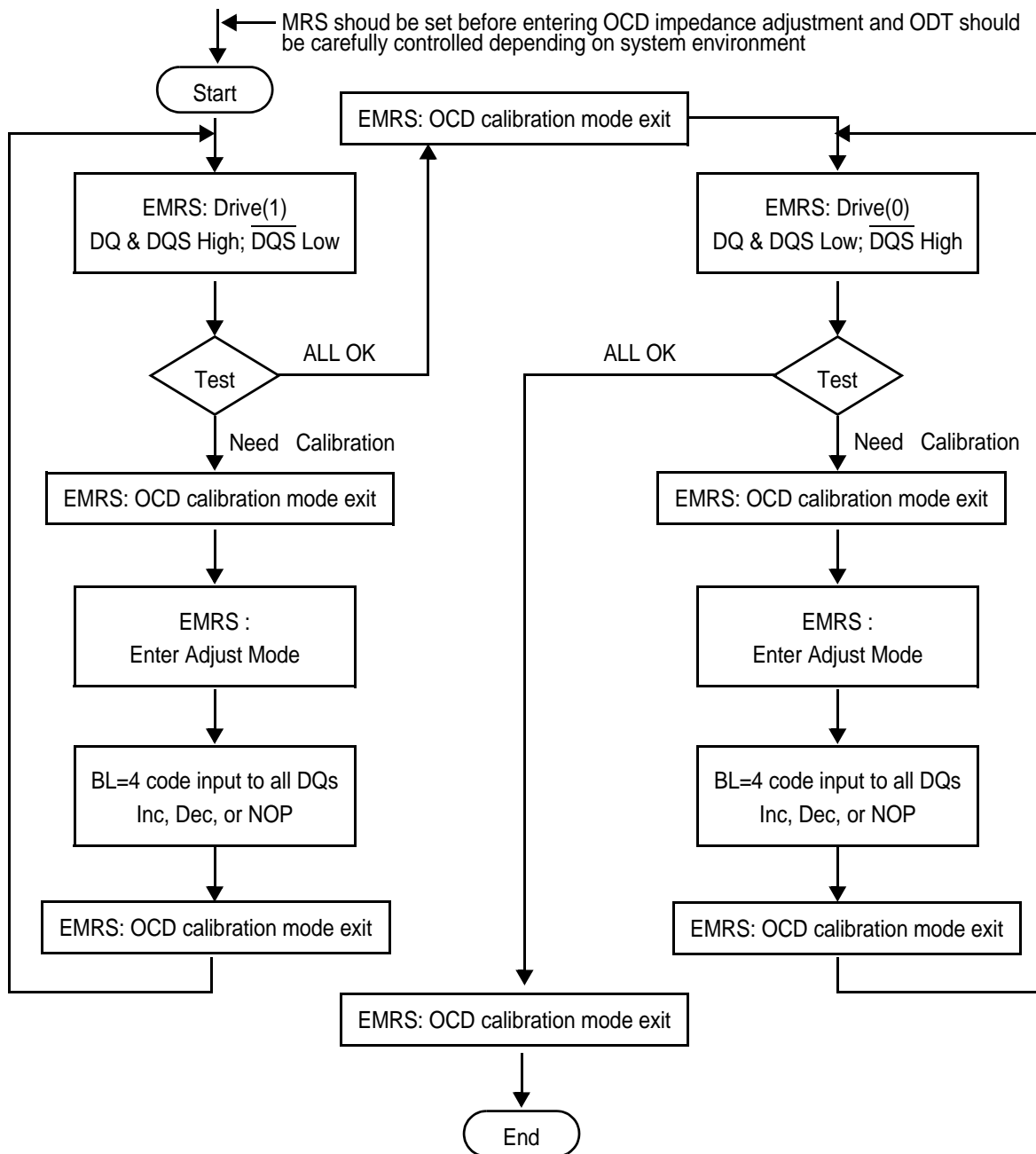

## Extended Mode Register Set for OCD impedance adjustment

OCD impedance adjustment can be done using the following EMRS mode. In drive mode all outputs are driven out by DDR2 SDRAM and drive of RDQS is dependent on EMRS bit enabling RDQS operation. In Drive(1) mode, all DQ, DQS (and RDQS) signals are driven high and all  $\overline{\text{DQS}}$  signals are driven low. In drive(0) mode, all DQ, DQS (and RDQS) signals are driven low and all  $\overline{\text{DQS}}$  signals are driven high. In adjust mode, BL = 4 of operation code data must be used. In case of OCD calibration default, output driver characteristics have a nominal impedance value of 18 ohms during nominal temperature and voltage conditions. Output driver characteristics for OCD calibration default are specified in Table x. OCD applies only to normal full strength output drive setting defined by EMRS(1) and if half strength is set, OCD default output driver

characteristics are not applicable. When OCD calibration adjust mode is used, OCD default output driver characteristics are not applicable. After OCD calibration is completed or driver strength is set to default, subsequent EMRS commands not intended to adjust OCD characteristics must specify A9-A7 as '000' in order to maintain the default or calibrated value.

### Off- Chip-Driver program

A9	A8	A7	Operation
0	0	0	OCD calibration mode exit
0	0	1	Drive(1) DQ, DQS, (RDQS) high and $\overline{\text{DQS}}$ low
0	1	0	Drive(0) DQ, DQS, (RDQS) low and $\overline{\text{DQS}}$ high
1	0	0	Adjust mode
1	1	1	OCD calibration default

### OCD impedance adjust

To adjust output driver impedance, controllers must issue the ADJUST EMRS command along with a 4bit burst code to DDR2 SDRAM as in table X. For this operation, Burst Length has to be set to BL = 4 via MRS command before activating OCD and controllers must drive this burst code to all DQs at the same time. DT0 in table X means all DQ bits at bit time 0, DT1 at bit time 1, and so forth. The driver output impedance is adjusted for all DDR2 SDRAM DQs simultaneously and after OCD calibration, all DQs of a given DDR2 SDRAM will be adjusted to the same driver strength setting. The maximum step count for adjustment is 16 and when the limit is reached, further increment or decrement code has no effect. The default setting may be any step within the 16 step range. When Adjust mode command is issued, AL from previously set value must be applied

Table X : Off- Chip-Driver Program

4bit burst code inputs to all DQs				Operation	
DT0	DT1	DT2	DT3	Pull-up driver strength	Pull-down driver strength
0	0	0	0	NOP (No operation)	NOP (No operation)
0	0	0	1	Increase by 1 step	NOP
0	0	1	0	Decrease by 1 step	NOP
0	1	0	0	NOP	Increase by 1 step
1	0	0	0	NOP	Decrease by 1 step
0	1	0	1	Increase by 1 step	Increase by 1 step
0	1	1	0	Decrease by 1 step	Increase by 1 step
1	0	0	1	Increase by 1 step	Decrease by 1 step
1	0	1	0	Decrease by 1 step	Decrease by 1 step
Other Combinations				Reserved	

For proper operation of adjust mode,  $WL = RL - 1 = AL + CL - 1$  clocks and tDS/tDH should be met as the following timing diagram. For input data pattern for adjustment, DT0 - DT3 is a fixed order and "not affected by

MRS addressing mode (ie. sequential or interleave).

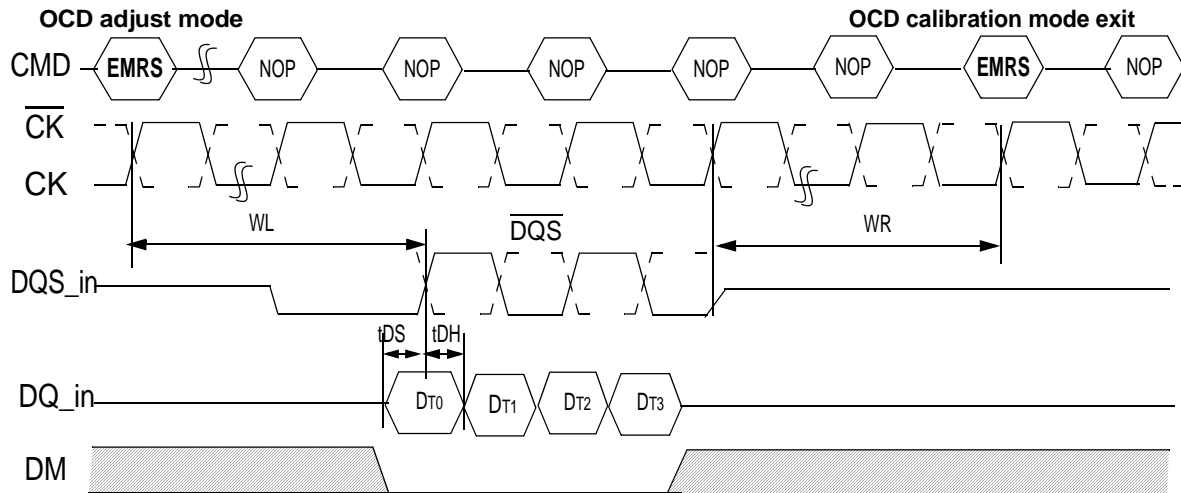

### Drive Mode

Drive mode, both Drive(1) and Drive(0), is used for controllers to measure DDR2 SDRAM Driver impedance. In this mode, all outputs are driven out **tOIT** after "enter drive mode" command and all output drivers are turned-off **tOIT** after "OCD calibration mode exit" command as the following timing diagram.

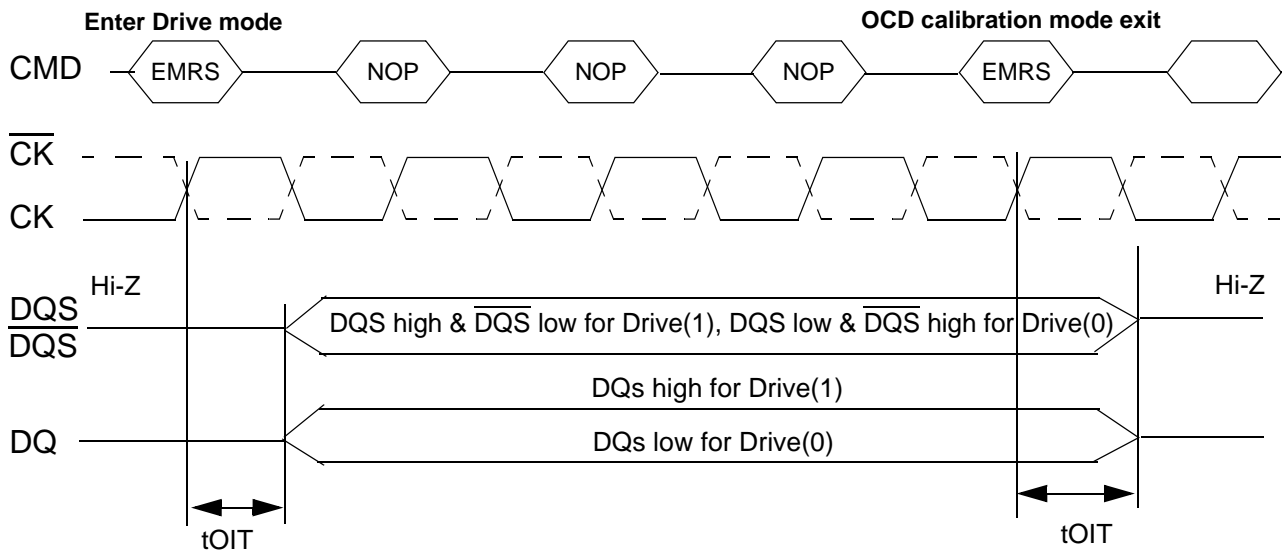

### 2.3.2.4 ODT (On Die Termination)

On Die Termination (ODT) is a feature that allows a DRAM to turn on/off termination resistance for each DQ, DQS/ $\overline{\text{DQS}}$ , RDQS/ $\overline{\text{RDQS}}$ , and DM signal for x4x8 configurations via the ODT control pin. For x16 configuration ODT is applied to each DQ, UDQS/ $\overline{\text{UDQS}}$ , LDQS/ $\overline{\text{LDQS}}$ , UDM, and LDM signal via the ODT control pin. The ODT feature is designed to improve signal integrity of the memory channel by allowing the DRAM controller to independently turn on/off termination resistance for any or all DRAM devices.

The ODT function is supported for ACTIVE and STANDBY modes. ODT is turned off and not supported in SELF REFRESH mode.

#### FUNCTIONAL REPRESENTATION OF ODT

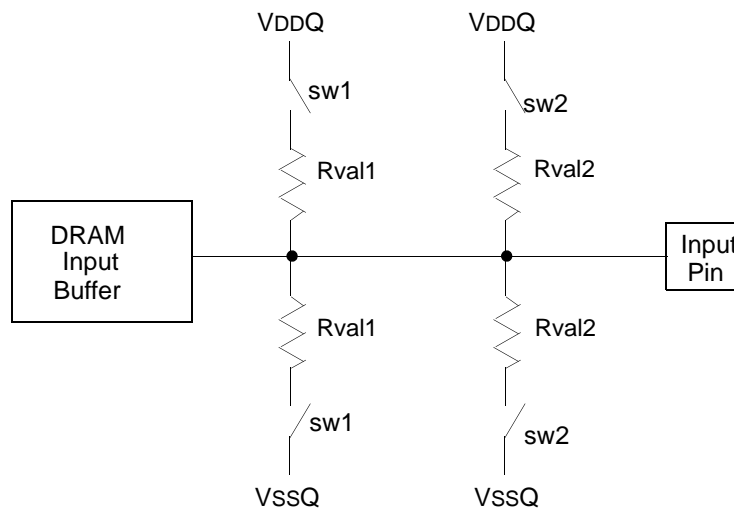

Switch sw1 or sw2 is enabled by ODT pin.  
 Selection between sw1 or sw2 is determined by "Rtt (nominal)" in EMRS  
 Termination included on all DQs, DM, DQS,  $\overline{\text{DQS}}$ , RDQS, and  $\overline{\text{RDQS}}$  pins.  
 Target Rtt (ohm) = (Rval1) / 2 or (Rval2) / 2

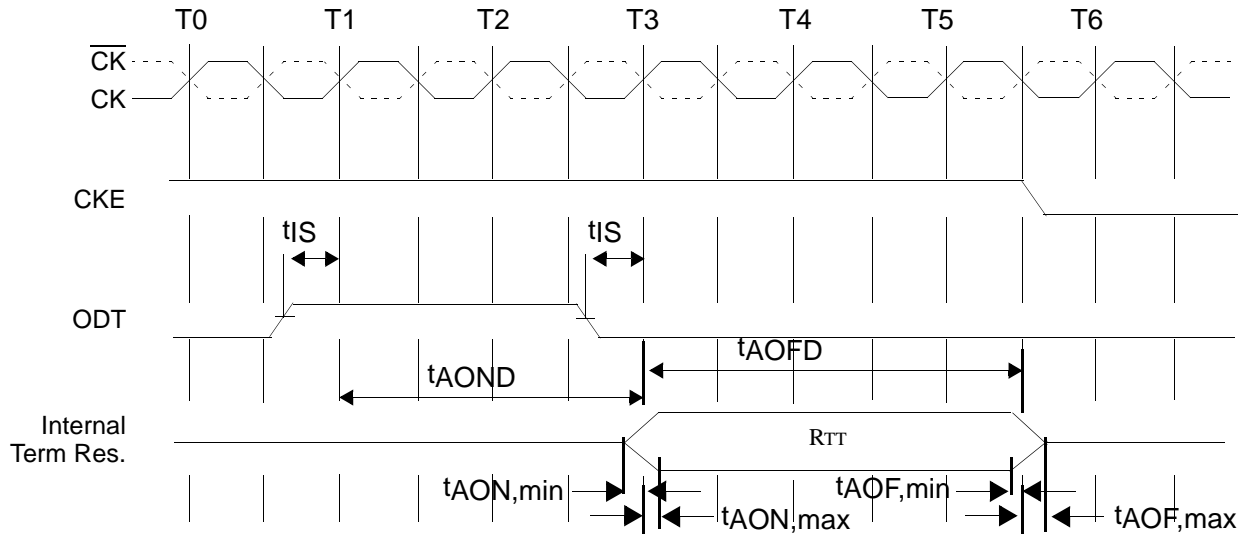
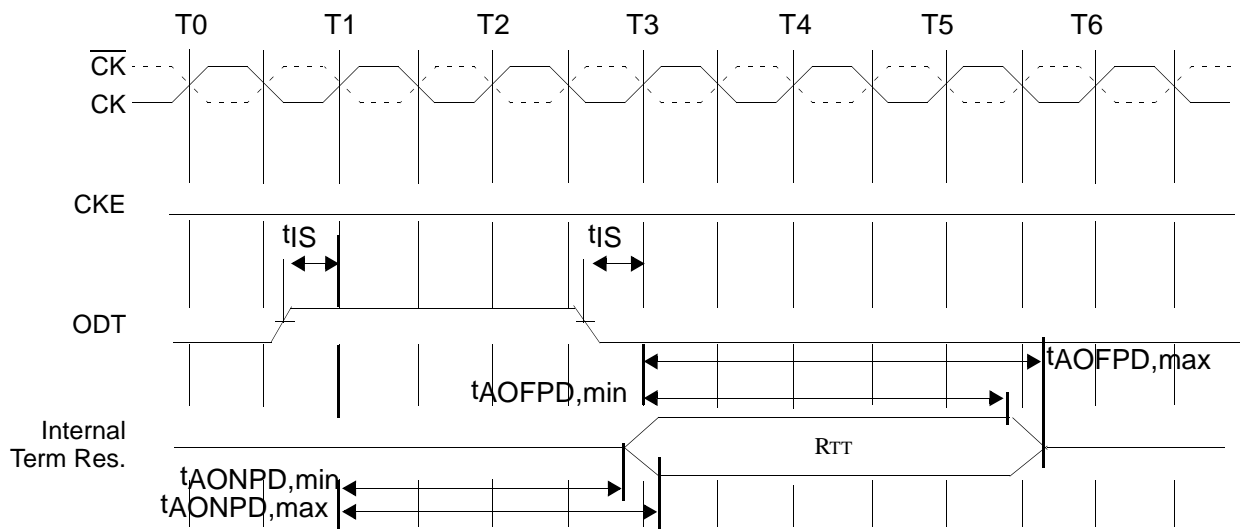
**ODT timing for active/standby mode**

**ODT timing for powerdown mode**

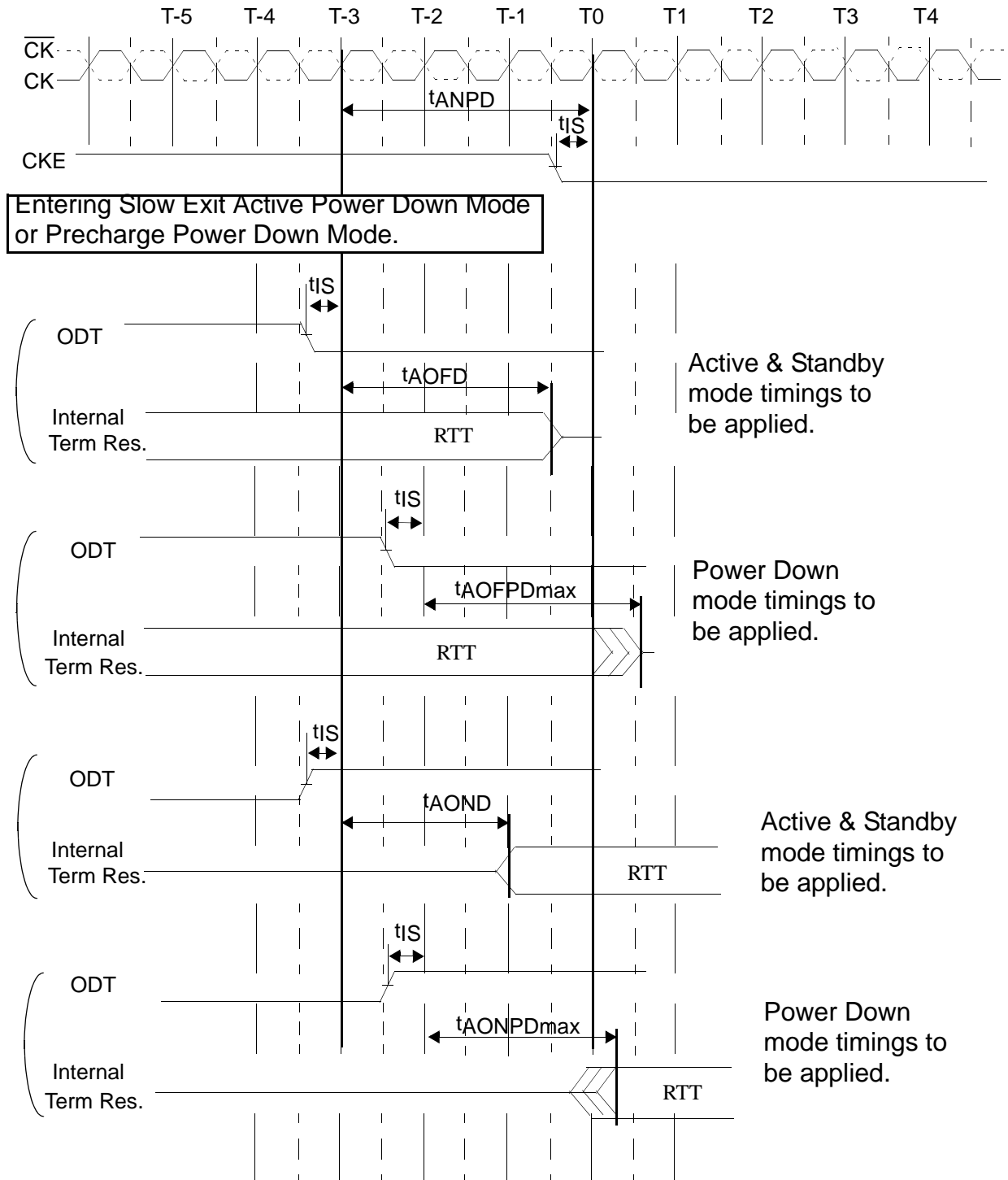
ODT timing mode switch at entering power down mode

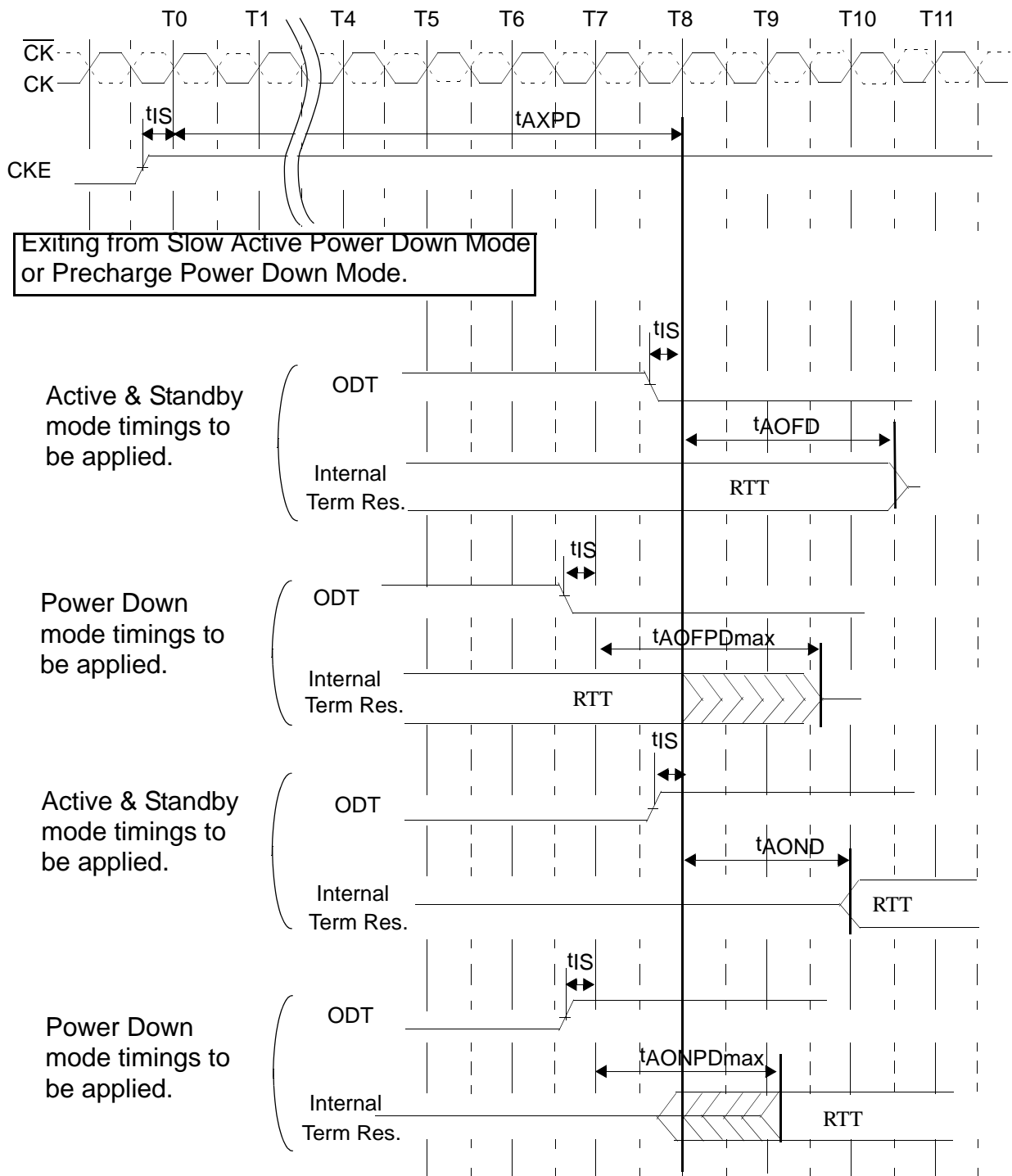

ODT timing mode switch at exiting power down mode



## 2.4 Bank Activate Command

The Bank Activate command is issued by holding  $\overline{\text{CAS}}$  and  $\overline{\text{WE}}$  high with  $\overline{\text{CS}}$  and  $\overline{\text{RAS}}$  low at the rising edge of the clock. The bank addresses BA0 ~ BA1 are used to select the desired bank. The row address A0 through A15 is used to determine which row to activate in the selected bank. The Bank Activate command must be applied before any Read or Write operation can be executed. Immediately after the bank active command, the DDR2 SDRAM can accept a read or write command on the following clock cycle. If a R/W command is issued to a bank that has not satisfied the  $t_{\text{RCDmin}}$  specification, then additive latency must be programmed into the device to delay when the R/W command is internally issued to the device. The additive latency value must be chosen to assure  $t_{\text{RCDmin}}$  is satisfied. Additive latencies of 0, 1, 2, 3, 4 and 5 are supported. Once a bank has been activated it must be precharged before another Bank Activate command can be applied to the same bank. The bank active and precharge times are defined as  $t_{\text{RAS}}$  and  $t_{\text{RP}}$ , respectively. The minimum time interval between successive Bank Activate commands to the same bank is determined by the RAS cycle time of the device ( $t_{\text{RC}}$ ). The minimum time interval between Bank Activate commands is  $t_{\text{RRD}}$ .

### Bank Activate Command Cycle: $t_{\text{RCD}} = 3$ , $\text{AL} = 2$ , $t_{\text{RP}} = 3$ , $t_{\text{RRD}} = 2$ , $t_{\text{CCD}} = 2$

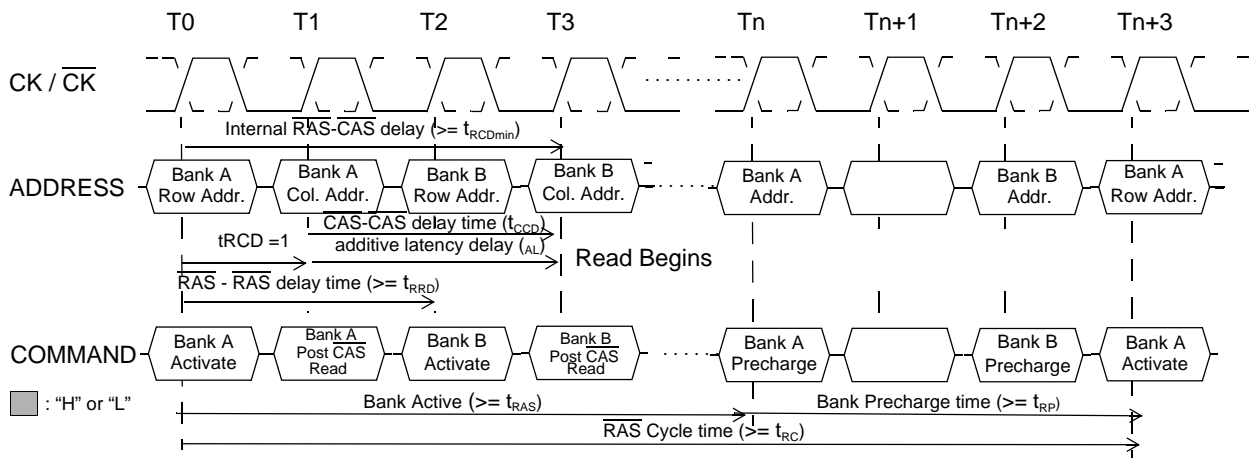

## 2.5 Read and Write Command

After a bank has been activated, a read or write cycle can be executed. This is accomplished by setting  $\overline{\text{RAS}}$  high,  $\overline{\text{CS}}$  and  $\overline{\text{CAS}}$  low at the clock's rising edge.  $\overline{\text{WE}}$  must also be defined at this time to determine whether the access cycle is a read operation ( $\overline{\text{WE}}$  high) or a write operation ( $\overline{\text{WE}}$  low).

The DDR2 SDRAM provides a fast column access operation. A single Read or Write Command will initiate a serial read or write operation on successive clock cycles. The boundary of the burst cycle is strictly restricted to specific segments of the page length. For example, the 32Mbit x 4 I/O x 4 Bank chip has a page length of 2048 bits (defined by CA0-CA9, CA11). The page length of 2048 is divided into 512 or 256 uniquely addressable boundary segments depending on burst length, 512 for 4 bit burst, 256 for 8 bit burst respectively. A 4-bit or 8 bit burst operation will occur entirely within one of the 512 or 256 groups beginning with the column address supplied to the device during the Read or Write Command (CA0-CA9, CA11). The second, third and fourth access will also occur within this group segment, however, the burst order is a function of the starting address, and the burst sequence.

A new burst access must not interrupt the previous 4 bit burst operation in case of BL = 4 setting. However, in case of BL = 8 setting, two cases of interrupt by a new burst access are allowed, one reads interrupted by a read, the other writes interrupted by a write with 4 bit burst boundary respectively. The minimum  $\overline{\text{CAS}}$  to  $\overline{\text{CAS}}$  delay is defined by tCCD, and is a minimum of 2 clocks for read or write cycles.

## 2.5.1 Posted CAS

Posted  $\overline{\text{CAS}}$  operation is supported to make command and data bus efficient for sustainable bandwidths in DDR2 SDRAM. In this operation, the DDR2 SDRAM allows a  $\overline{\text{CAS}}$  read or write command to be issued immediately after the RAS bank activate command (or any time during the  $\overline{\text{RAS}}$ -CAS-delay time,  $t_{\text{RCD}}$ , period). The command is held for the time of the Additive Latency (AL) before it is issued inside the device. The Read Latency (RL) is controlled by the sum of AL and the  $\overline{\text{CAS}}$  latency (CL). Therefore if a user chooses to issue a R/W command before the  $t_{\text{RCDmin}}$ , then AL (greater than 0) must be written into the EMRS(1). The Write Latency (WL) is always defined as  $\text{RL} - 1$  (read latency -1) where read latency is defined as the sum of additive latency plus CAS latency ( $\text{RL} = \text{AL} + \text{CL}$ ). Read or Write operations using AL allow seamless bursts (refer to seamless operation timing diagram examples in Read burst and Write burst section)

### Examples of posted CAS operation

Example 1 Read followed by a write to the same bank

[AL = 2 and CL = 3, RL = (AL + CL) = 5, WL = (RL - 1) = 4, BL = 4]

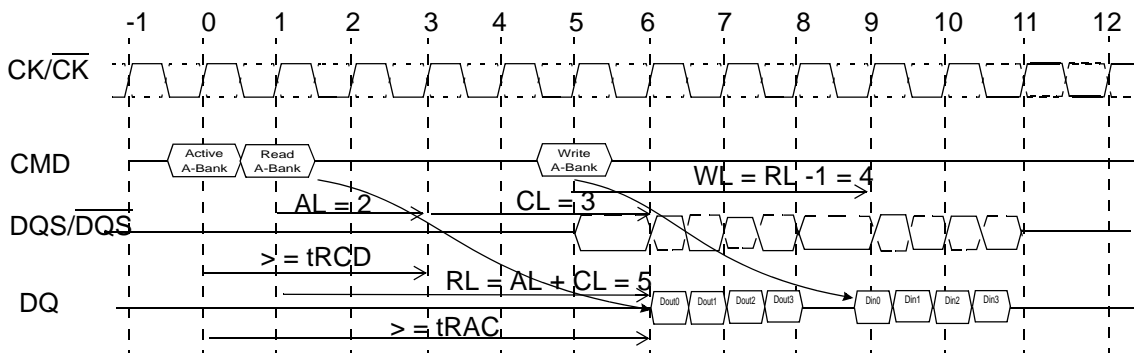

Example 2 Read followed by a write to the same bank

[AL = 0 and CL = 3, RL = (AL + CL) = 3, WL = (RL - 1) = 2, BL = 4]

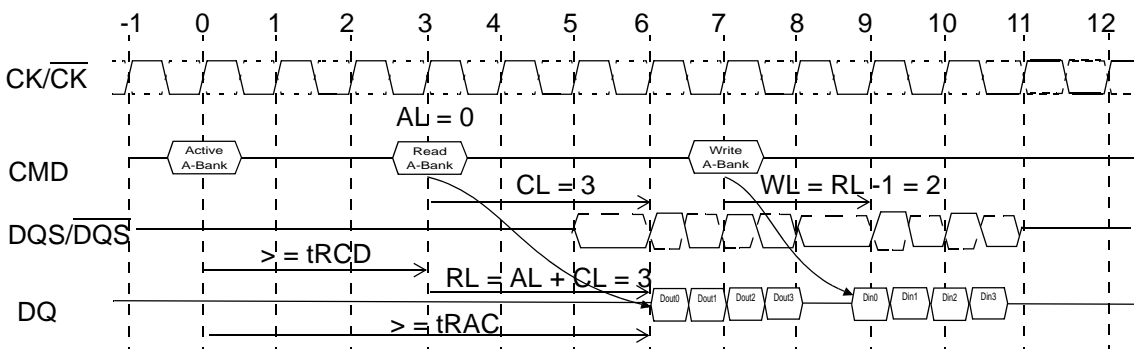

## 2.5.2 Burst Mode Operation

Burst mode operation is used to provide a constant flow of data to memory locations (write cycle), or from memory locations (read cycle). The parameters that define how the burst mode will operate are burst sequence and burst length. DDR2 SDRAM supports 4 bit burst and 8 bit burst modes only. For 8 bit burst mode, full interleave address ordering is supported, however, sequential address ordering is nibble based for ease of implementation. The burst type, either sequential or interleaved, is programmable and defined by the address bit 3 (A3) of the MRS, which is similar to the DDR SDRAM operation. Seamless burst read or write operations are supported. Unlike DDR devices, interruption of a burst read or write cycle during BL = 4 mode operation is prohibited. However in case of BL = 8 mode, interruption of a burst read or write operation is limited to two cases, reads interrupted by a read, or writes interrupted by a write. Therefore the Burst Stop command is not supported on DDR2 SDRAM devices.

### Burst Length and Sequence

Burst Length	Starting Address (A2 A1 A0)	Sequential Addressing (decimal)	Interleave Addressing (decimal)
4	0 0 0	0, 1, 2, 3	0, 1, 2, 3
	0 0 1	1, 2, 3, 0	1, 0, 3, 2
	0 1 0	2, 3, 0, 1	2, 3, 0, 1
	0 1 1	3, 0, 1, 2	3, 2, 1, 0
8	0 0 0	0, 1, 2, 3, 4, 5, 6, 7	0, 1, 2, 3, 4, 5, 6, 7
	0 0 1	1, 2, 3, 0, 5, 6, 7, 4	1, 0, 3, 2, 5, 4, 7, 6
	0 1 0	2, 3, 0, 1, 6, 7, 4, 5	2, 3, 0, 1, 6, 7, 4, 5
	0 1 1	3, 0, 1, 2, 7, 4, 5, 6	3, 2, 1, 0, 7, 6, 5, 4
	1 0 0	4, 5, 6, 7, 0, 1, 2, 3	4, 5, 6, 7, 0, 1, 2, 3
	1 0 1	5, 6, 7, 4, 1, 2, 3, 0	5, 4, 7, 6, 1, 0, 3, 2
	1 1 0	6, 7, 4, 5, 2, 3, 0, 1	6, 7, 4, 5, 2, 3, 0, 1
	1 1 1	7, 4, 5, 6, 3, 0, 1, 2	7, 6, 5, 4, 3, 2, 1, 0

Note: Page length is a function of I/O organization and column addressing

### 2.5.3 Burst Read Command

The Burst Read command is initiated by having  $\overline{CS}$  and  $\overline{CAS}$  low while holding  $\overline{RAS}$  and  $\overline{WE}$  high at the rising edge of the clock. The address inputs determine the starting column address for the burst. The delay from the start of the command to when the data from the first cell appears on the outputs is equal to the value of the read latency (RL). The data strobe output (DQS) is driven low 1 clock cycle before valid data (DQ) is driven onto the data bus. The first bit of the burst is synchronized with the rising edge of the data strobe (DQS). Each subsequent data-out appears on the  $\overline{DQ}$  pin in phase with the DQS signal in a source synchronous manner. The RL is equal to an additive latency (AL) plus CAS latency (CL). The CL is defined by the Mode Register Set (MRS), similar to the existing SDR and DDR SDRAMs. The AL is defined by the Extended Mode Register Set (1)(EMRS(1)).

DDR2 SDRAM pin timings are specified for either single ended mode or differential mode depending on the setting of the EMRS(1) "Enable DQS" mode bit; timing advantages of differential mode are realized in system design. The method by which the DDR2 SDRAM pin timings are measured is mode dependent. In single ended mode, timing relationships are measured relative to the rising or falling edges of DQS crossing at VREF. In differential mode, these timing relationships are measured relative to the crosspoint of DQS and its complement,  $\overline{DQS}$ . This distinction in timing methods is guaranteed by design and characterization. Note that when differential data strobe mode is disabled via the EMRS, the complementary pin,  $\overline{DQS}$ , must be tied externally to VSS through a 20 ohm to 10 Kohm resistor to insure proper operation.

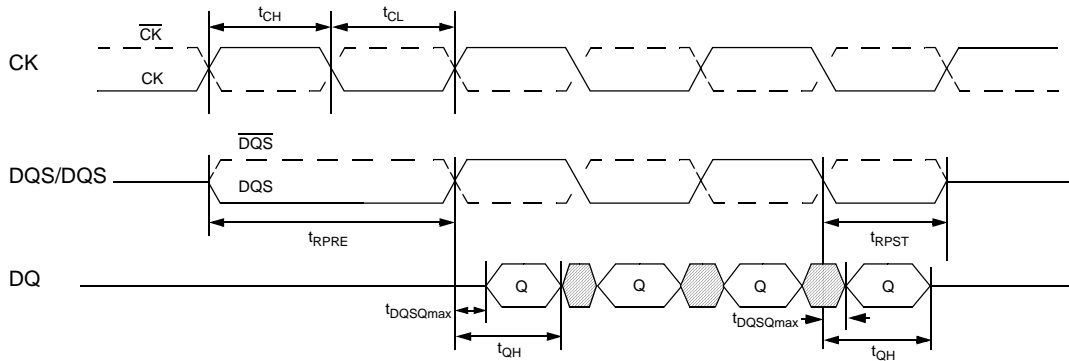
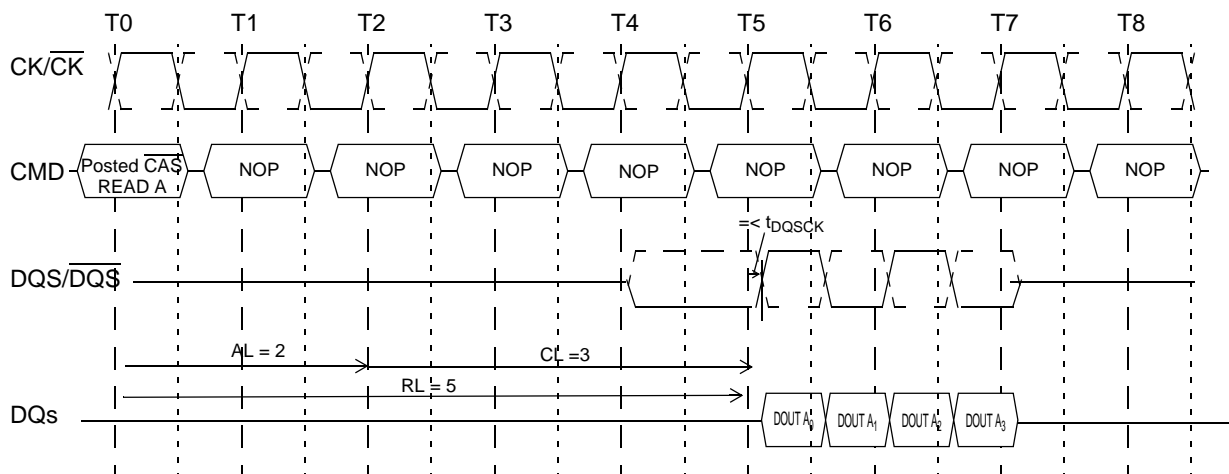
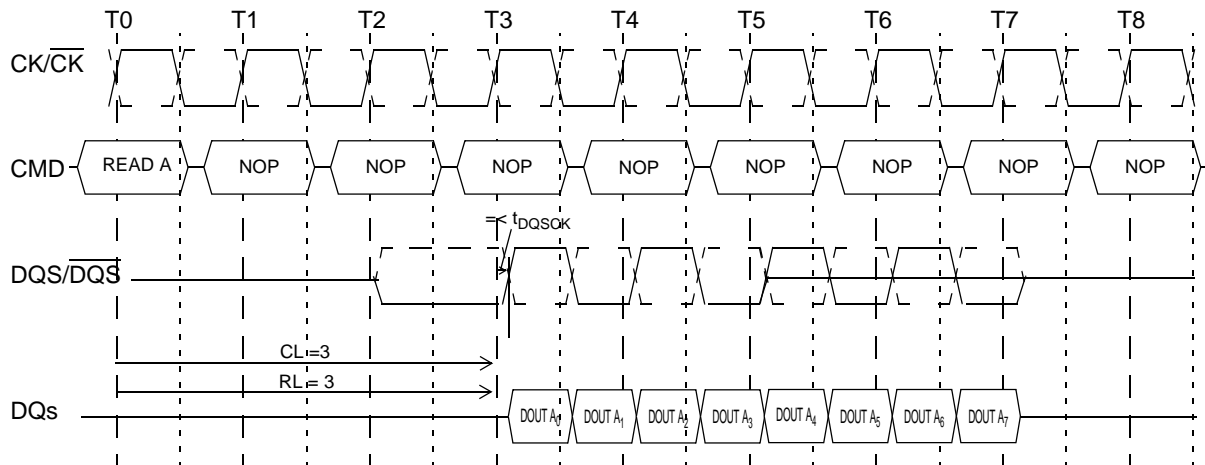
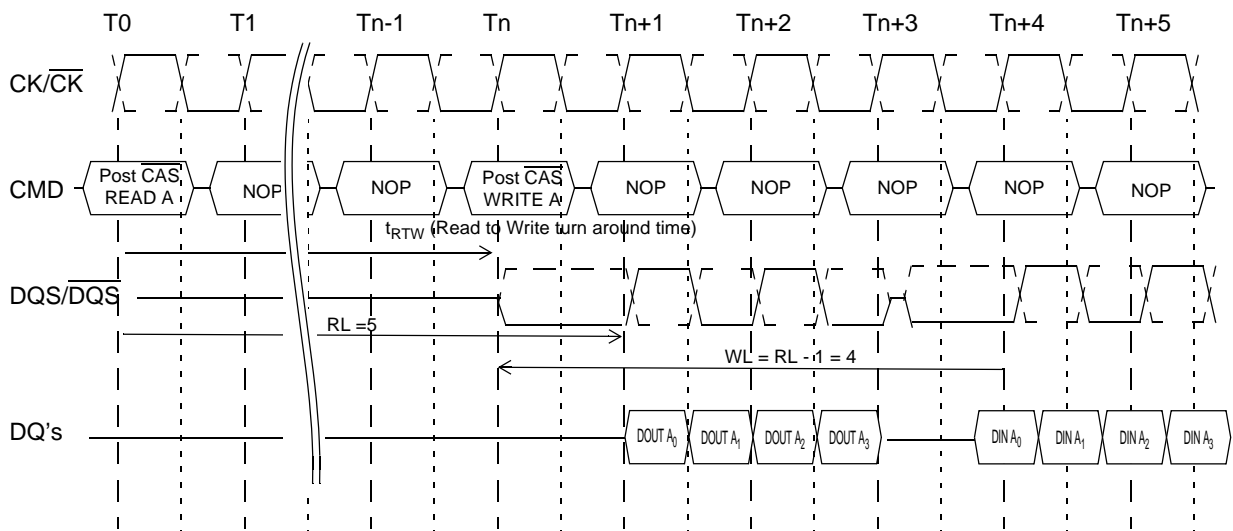

Figure YY-- Data output (read) timing

#### Burst Read Operation: RL = 5 (AL = 2, CL = 3, BL = 4)



**Burst Read Operation: RL = 3 (AL = 0 and CL = 3, BL = 8)**

**Burst Read followed by Burst Write: RL = 5, WL = (RL-1) = 4, BL = 4**

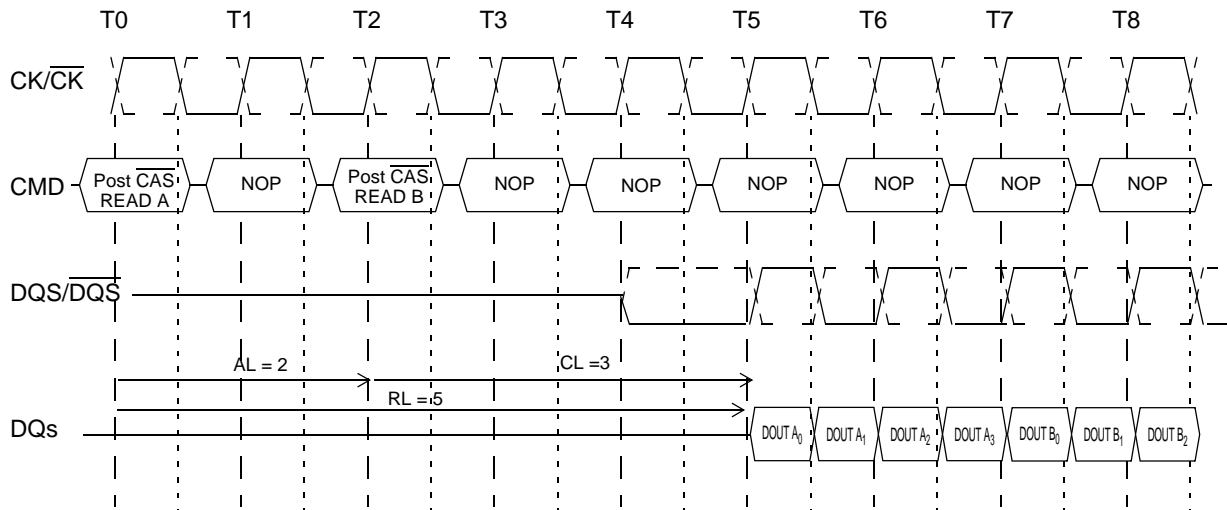
The minimum time from the burst read command to the burst write command is defined by a read-to-write-turn-around-time, which is 4 clocks in case of BL = 4 operation, 6 clocks in case of BL = 8 operation.

**Seamless Burst Read Operation: RL = 5, AL = 2, and CL = 3, BL = 4**

The seamless burst read operation is supported by enabling a read command at every other clock for BL = 4 operation, and every 4 clock for BL = 8 operation. This operation is allowed regardless of same or different banks as long as the banks are activated.

## Reads interrupted by a read

Burst read can only be interrupted by another read with 4 bit burst boundary. Any other case of read interrupt is not allowed.

Read Burst Interrupt Timing Example: (CL=3, AL=0, RL=3, BL=8)

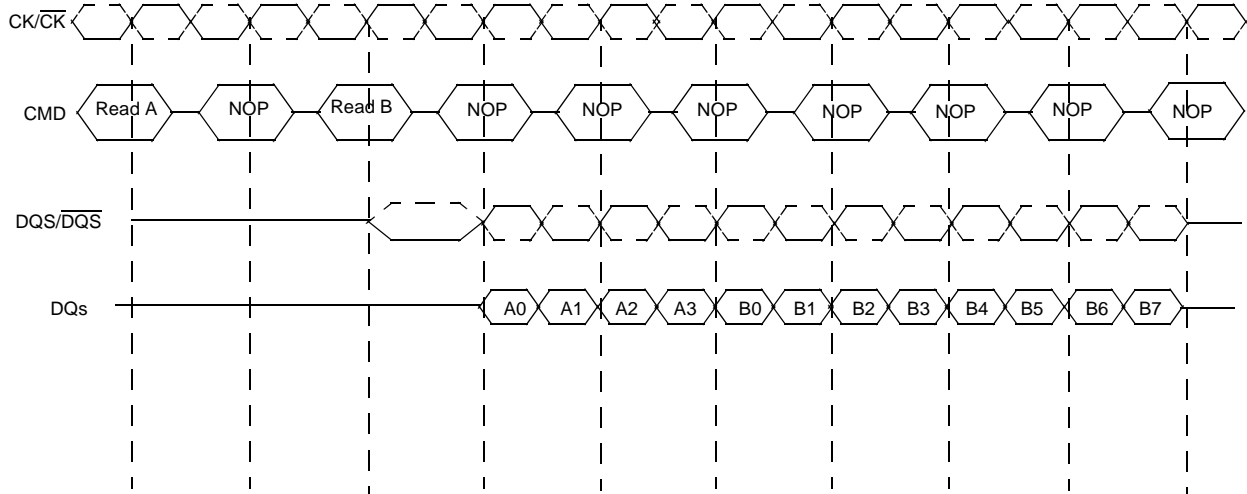

### Note

1. Read burst interrupt function is only allowed on burst of 8. Burst interrupt of 4 is prohibited.
2. Read burst of 8 can only be interrupted by another Read command. Read burst interruption by Write command or Precharge command is prohibited.
3. Read burst interrupt must occur exactly two clocks after previous Read command. Any other Read burst interrupt timings are prohibited.
4. Read burst interruption is allowed to any bank inside DRAM.
5. Read burst with Auto Precharge enabled is not allowed to interrupt.
6. Read burst interruption is allowed by another Read with Auto Precharge command.
7. All command timings are referenced to burst length set in the mode register. They are not referenced to actual burst. For example, Minimum Read to Precharge timing is  $AL + BL/2$  where BL is the burst length set in the mode register and not the actual burst (which is shorter because of interrupt).

### 2.5.4 Burst Write Operation

The Burst Write command is initiated by having  $\overline{CS}$ ,  $\overline{CAS}$  and  $\overline{WE}$  low while holding  $\overline{RAS}$  high at the rising edge of the clock. The address inputs determine the starting column address. Write latency (WL) is defined by a read latency (RL) minus one and is equal to  $(AL + CL - 1)$ . A data strobe signal (DQS) should be driven low (preamble) one clock prior to the WL. The first data bit of the burst cycle must be applied to the DQ pins at the first rising edge of the DQS following the preamble. The  $t_{DQSS}$  specification must be satisfied for write cycles. The subsequent burst bit data are issued on successive edges of the DQS until the burst length is completed, which is 4 or 8 bit burst. When the burst has finished, any additional data supplied to the DQ pins will be ignored. The DQ Signal is ignored after the burst write operation is complete. The time from the completion of the burst write to bank precharge is the write recovery time (WR). DDR2 SDRAM pin timings are specified for either single ended mode or differential mode depending on the setting of the EMRS "Enable DQS" mode bit; timing advantages of differential mode are realized in system design. The method by which the DDR2 SDRAM pin timings are measured is mode dependent. In single ended mode, timing relationships are measured relative to the rising or falling edges of DQS crossing at  $V_{REF}$ . In differential mode, these timing relationships are measured relative to the crosspoint of DQS and its complement,  $\overline{DQS}$ . This distinction in timing methods is guaranteed by design and characterization. Note that when differential data strobe mode is disabled via the EMRS, the complementary pin,  $\overline{DQS}$ , must be tied externally to VSS through a 20 ohm to 10 Kohm resistor to insure proper operation.

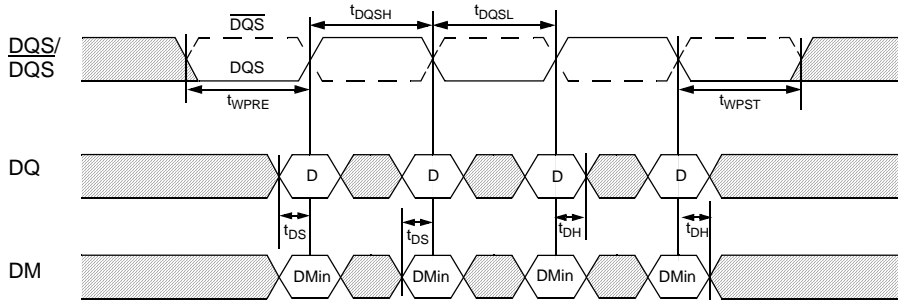

Data input (write) timing

#### Burst Write Operation: RL = 5, WL = 4, tWR = 3 (AL=2, CL=3), BL = 4

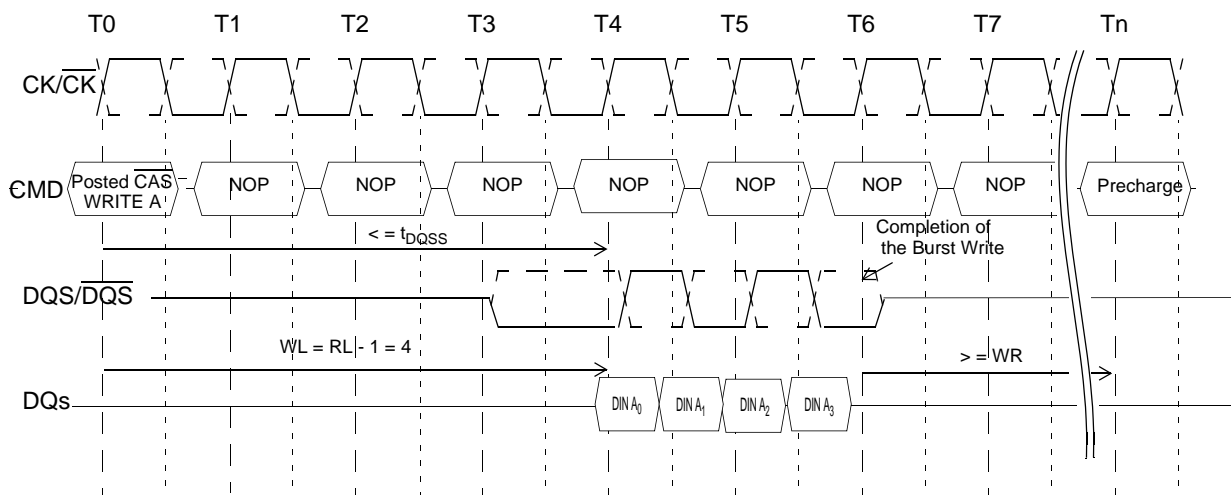

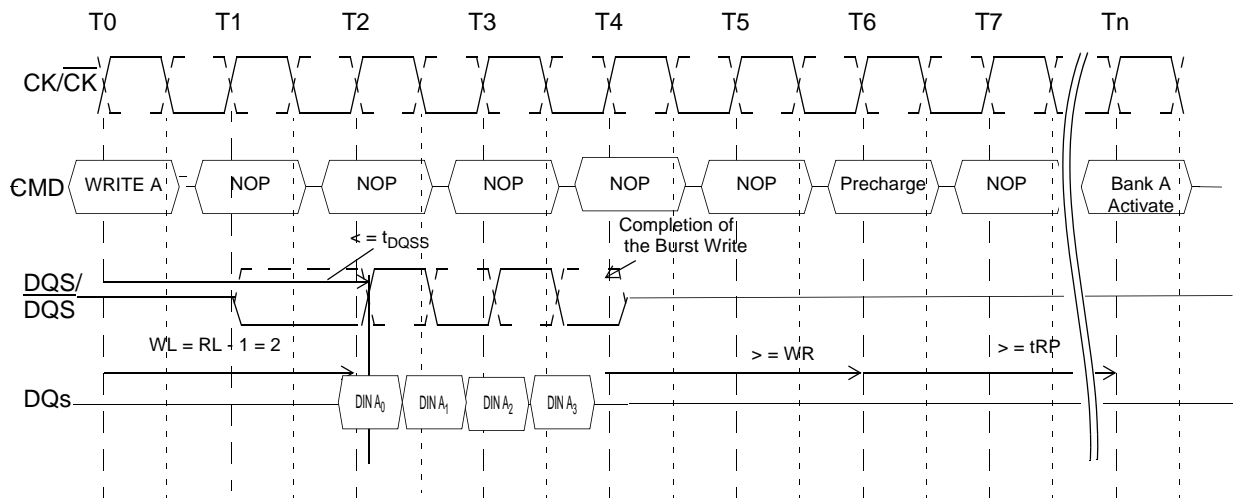
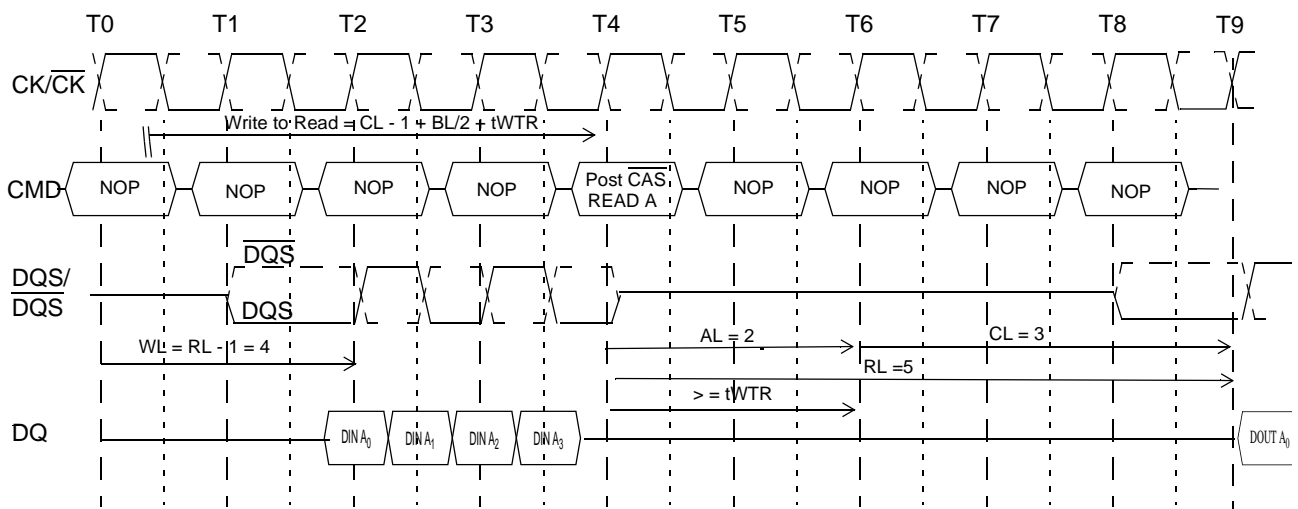
**Burst Write Operation: RL = 3, WL = 2, tWR = 2 (AL=0, CL=3), BL = 4**

**Burst Write followed by Burst Read: RL = 5 (AL=2, CL=3), WL = 4, tWTR = 2, BL = 4**

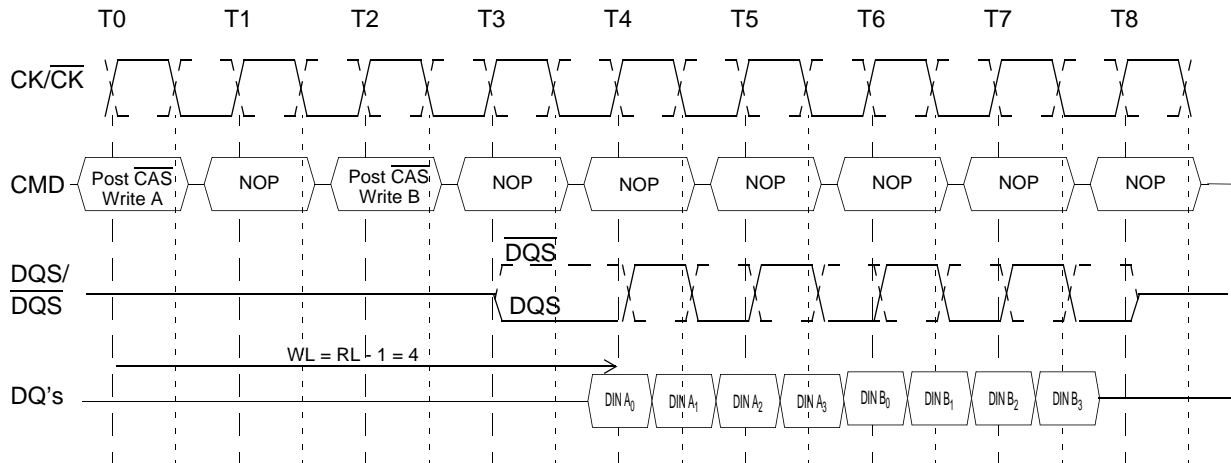
The minimum number of clock from the burst write command to the burst read command is  $[CL - 1 + BL/2 + tWTR]$ . This  $tWTR$  is not a write recovery time ( $tWR$ ) but the time required to transfer the 4bit write data from the input buffer into sense amplifiers in the array.  $tWTR$  is defined in AC spec table of this data sheet.

**Seamless Burst Write Operation: RL = 5, WL = 4, BL = 4**

The seamless burst write operation is supported by enabling a write command every other clock for BL = 4 operation, every four clocks for BL = 8 operation. This operation is allowed regardless of same or different banks as long as the banks are activated

## Writes interrupted by a write

Burst write can only be interrupted by another write with 4 bit burst boundary. Any other case of write interrupt is not allowed.

Write Burst Interrupt Timing Example: (CL=3, AL=0, RL=3, WL=2, BL=8)

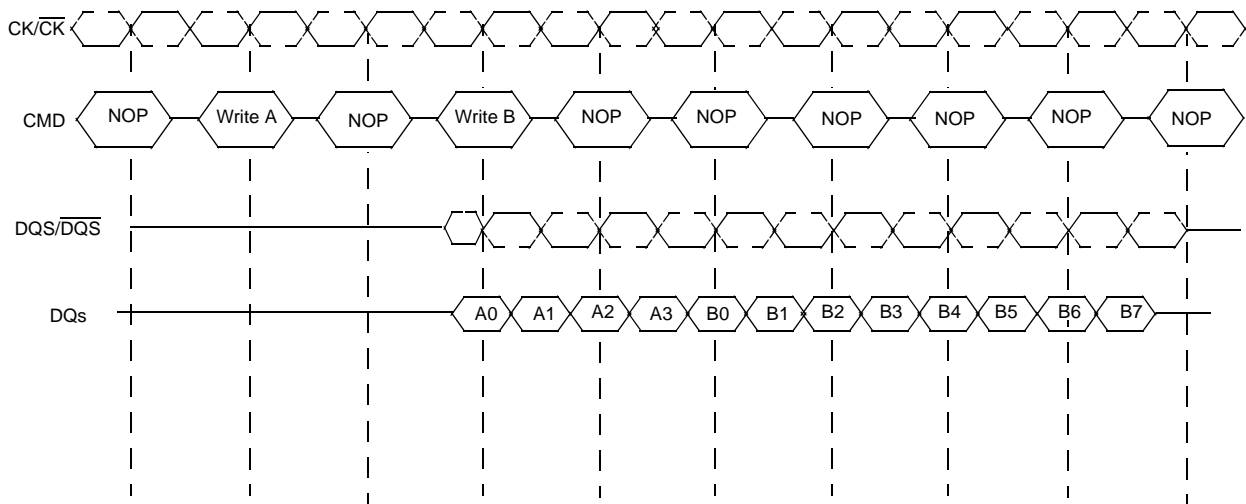

### Notes:

1. Write burst interrupt function is only allowed on burst of 8. Burst interrupt of 4 is prohibited.
2. Write burst of 8 can only be interrupted by another Write command. Write burst interruption by Read command or Precharge command is prohibited.
3. Write burst interrupt must occur exactly two clocks after previous Write command. Any other Write burst interrupt timings are prohibited.
4. Write burst interruption is allowed to any bank inside DRAM.
5. Write burst with Auto Precharge enabled is not allowed to interrupt.
6. Write burst interruption is allowed by another Write with Auto Precharge command.
7. All command timings are referenced to burst length set in the mode register. They are not referenced to actual burst. For example, minimum Write to Precharge timing is  $WL + BL/2 + tWR$  where  $tWR$  starts with the rising clock after the un-interrupted burst end and not from the end of actual burst end.

### 2.5.5 Write Data Mask

One write data mask (DM) pin for each 8 data bits (DQ) will be supported on DDR2 SDRAMs, Consistent with the implementation on DDR SDRAMs. It has identical timings on write operations as the data bits, and though used in a uni-directional manner, is internally loaded identically to data bits to insure matched system timing. DM of x4 and x16 bit organization is not used during read cycles. However DM of x8 bit organization can be used as RDQS during read cycles by EMRS(1) setting.

#### Data Mask Timing

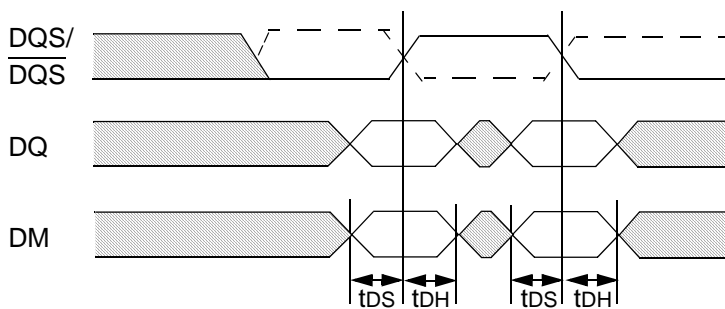

#### Data Mask Function, WL=3, AL=0, BL = 4 shown

##### Case 1 : min $t_{DQSS}$

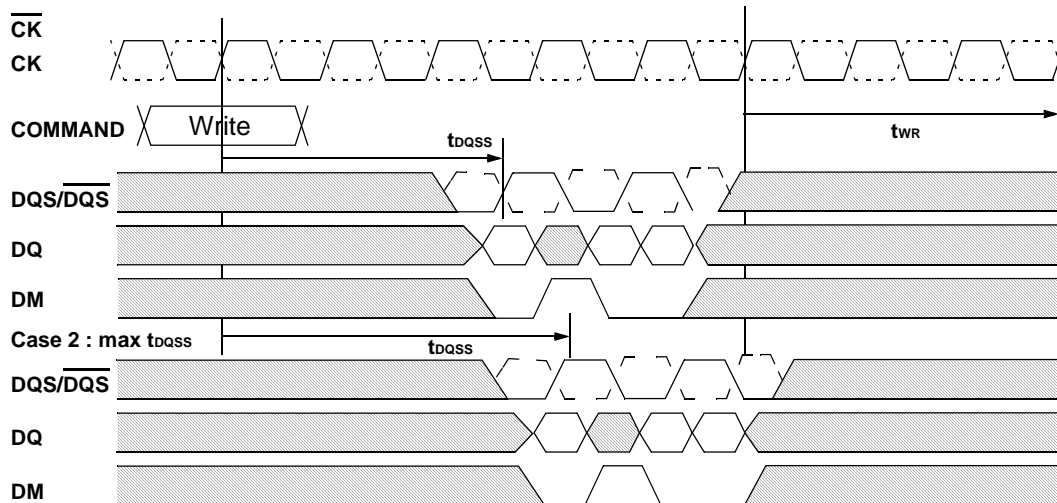

##### Case 2 : max $t_{DQSS}$

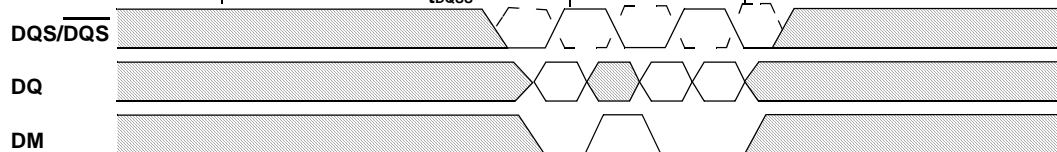

## 2.6 Precharge Operation

The Precharge Command is used to precharge or close a bank that has been activated. The Precharge Command is triggered when  $\overline{CS}$ ,  $\overline{RAS}$  and  $\overline{WE}$  are low and  $\overline{CAS}$  is high at the rising edge of the clock. The Precharge Command can be used to precharge each bank independently or all banks simultaneously. Three address bits A10, BA0 and BA1 for 256Mb are used to define which bank to precharge when the command is issued.

**Bank Selection for Precharge by Address Bits**

A10	BA1	BA0	Precharged Bank(s)	Remarks
LOW	LOW	LOW	Bank 0 only	
LOW	LOW	HIGH	Bank 1 only	
LOW	HIGH	LOW	Bank 2 only	
LOW	HIGH	HIGH	Bank 3 only	
HIGH	DON'T CARE	DON'T CARE	All Banks	

### Burst Read Operation Followed by Precharge

Minimum Read to precharge command spacing to the same bank =  $AL + BL/2$  clocks

For the earliest possible precharge, the precharge command may be issued on the rising edge which is "Additive latency(AL) + BL/2 clocks" after a Read command. A new bank active (command) may be issued to the same bank after the RAS precharge time ( $t_{RP}$ ). A precharge command cannot be issued until  $t_{RAS}$  is satisfied.

The minimum Read to Precharge spacing has also to satisfy a minimum analog time from the rising clock edge that initiates the last 4-bit prefetch of a Read to Precharge command. This time is called  $t_{RTP}$  (Read to Precharge). For BL = 4 this is the time from the actual read (AL after the Read command) to Precharge command. For BL = 8 this is the time from AL + 2 clocks after the Read to the Precharge command.

**Example 1: Burst Read Operation Followed by Precharge:**  
**RL = 4, AL = 1, CL = 3, BL = 4,  $t_{RTP} \leq 2$  clocks**

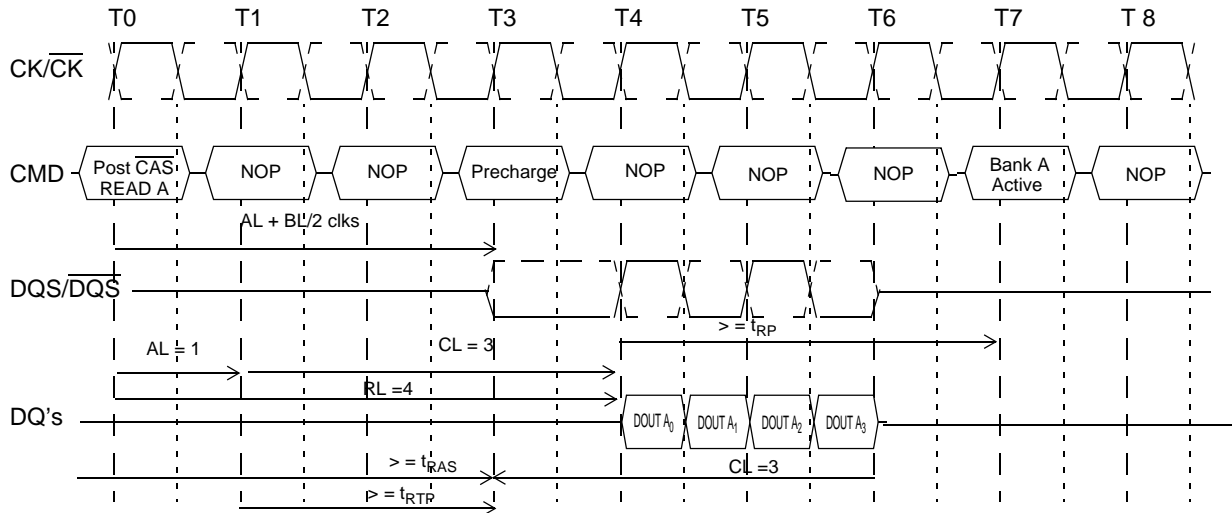

**Example 2: Burst Read Operation Followed by Precharge:**  
**RL = 4, AL = 1, CL = 3, BL = 8,  $t_{RTP} \leq 2$  clocks**

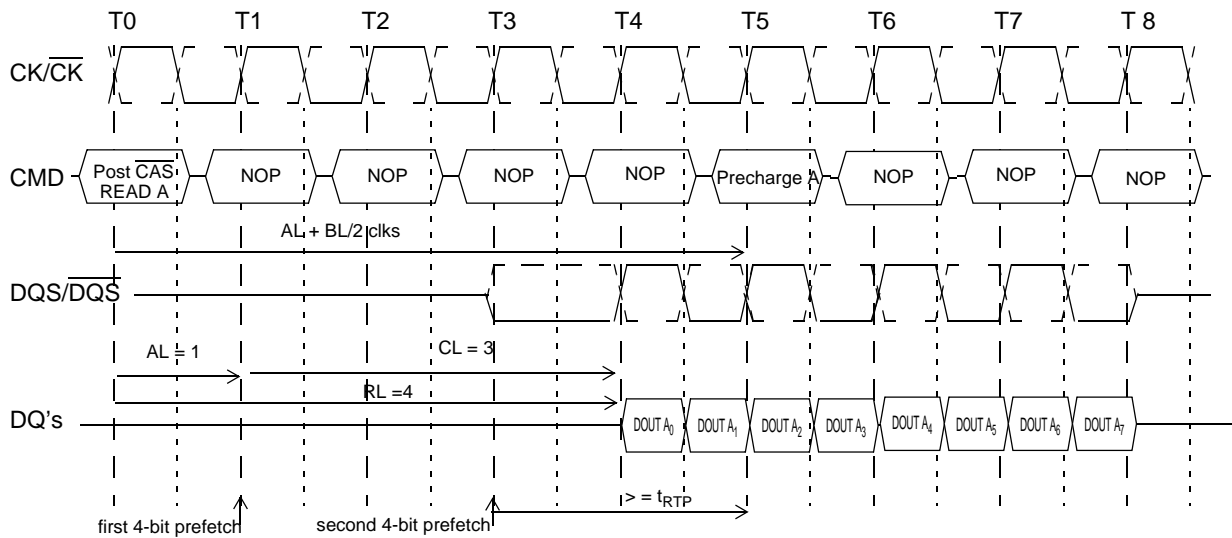

**Example 3: Burst Read Operation Followed by Precharge:**  
**RL = 5, AL = 2, CL = 3, BL = 4,  $t_{RTP} \leq 2$  clocks**

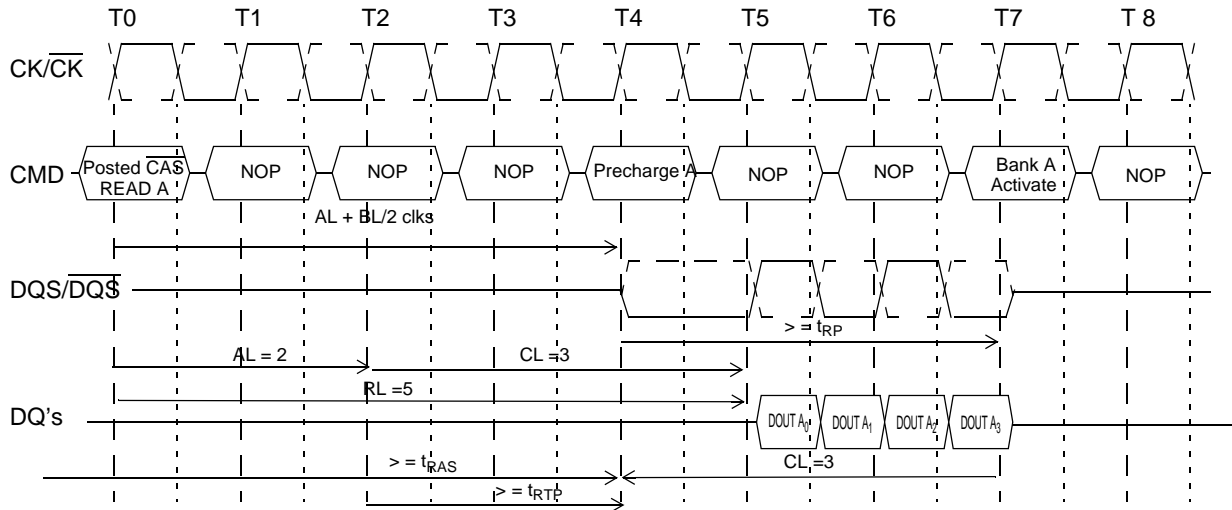

**Example 4: Burst Read Operation Followed by Precharge:**  
**RL = 6, AL = 2, CL = 4, BL = 4,  $t_{RTP} \leq 2$  clocks**

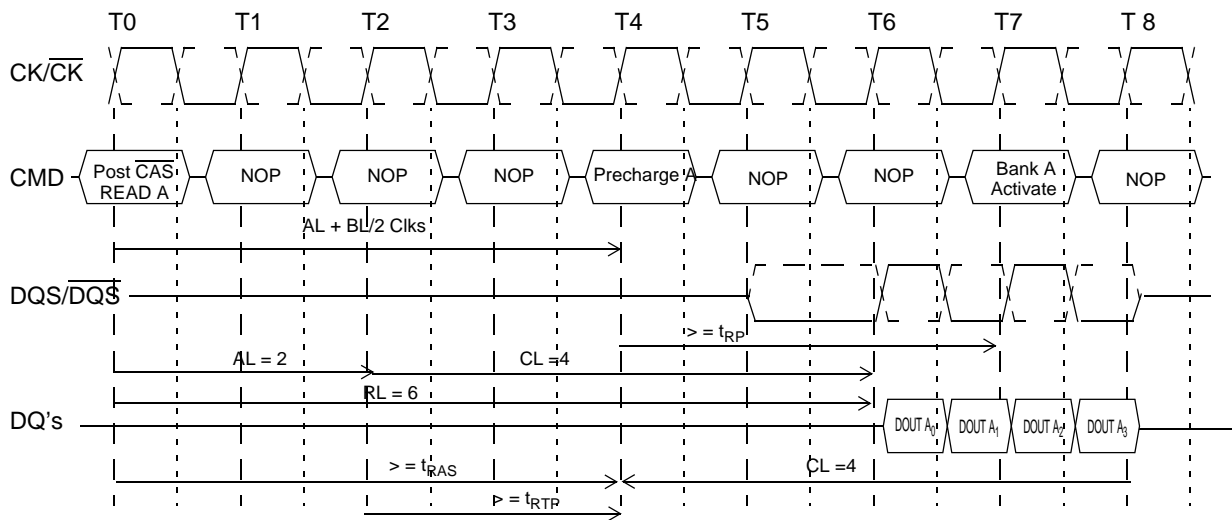

**Example 5: Burst Read Operation Followed by Precharge:**  
**RL = 4, AL = 0, CL = 4, BL = 8,  $t_{RTP} > 2$  clocks**

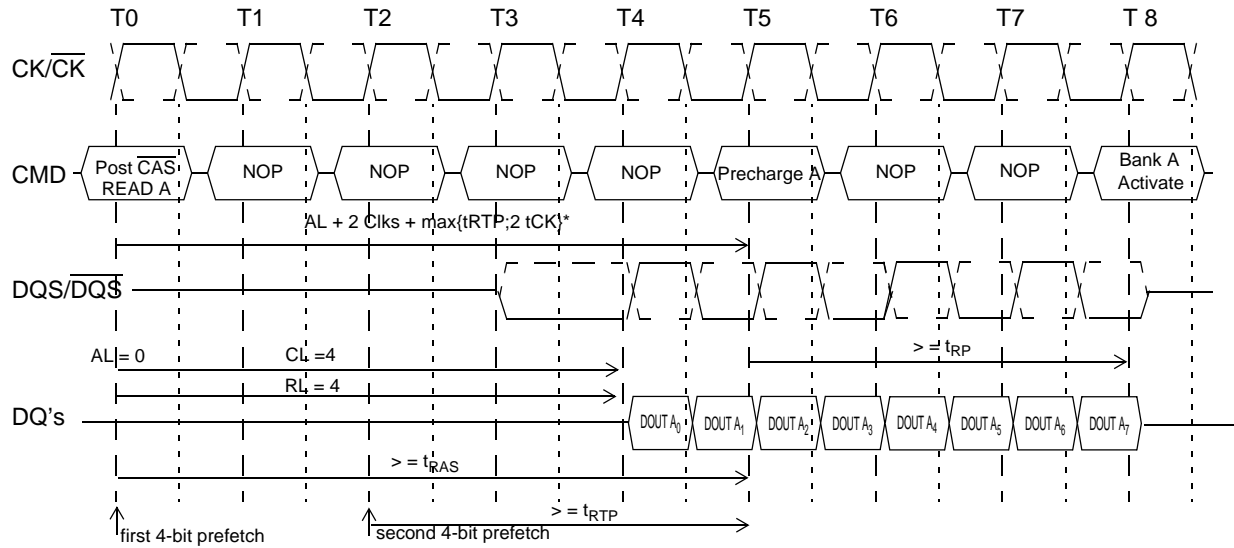

\* : rounded to next interger

## Burst Write followed by Precharge

Minimum Write to Precharge Command spacing to the same bank =  $WL + BL/2 \text{ clks} + tWR$

For write cycles, a delay must be satisfied from the completion of the last burst write cycle until the Precharge Command can be issued. This delay is known as a write recovery time ( $tWR$ ) referenced from the completion of the burst write to the precharge command. No Precharge command should be issued prior to the  $tWR$  delay.

### Example 1: Burst Write followed by Precharge: $WL = (RL-1) = 3$

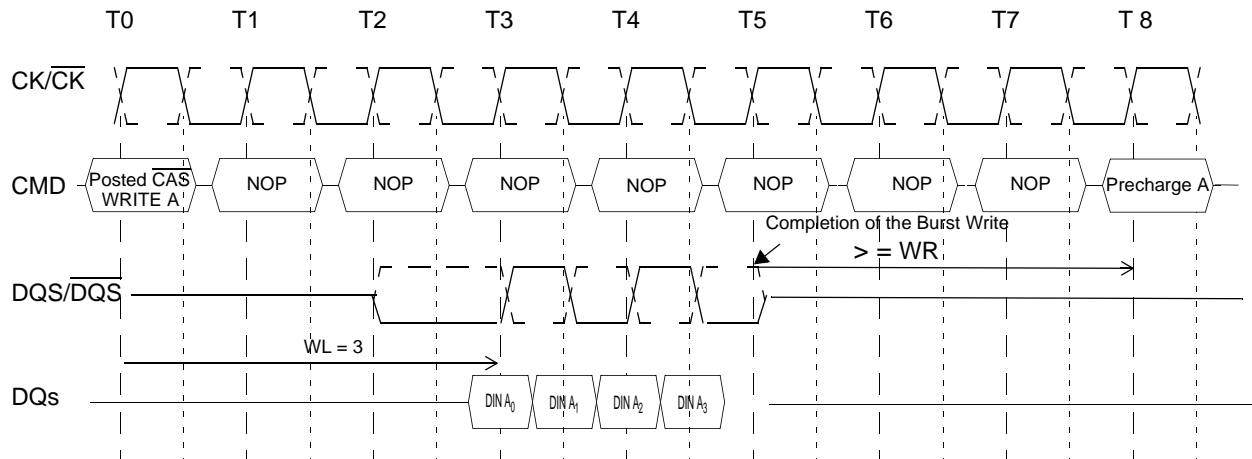

### Example 2: Burst Write followed by Precharge: $WL = (RL-1) = 4$

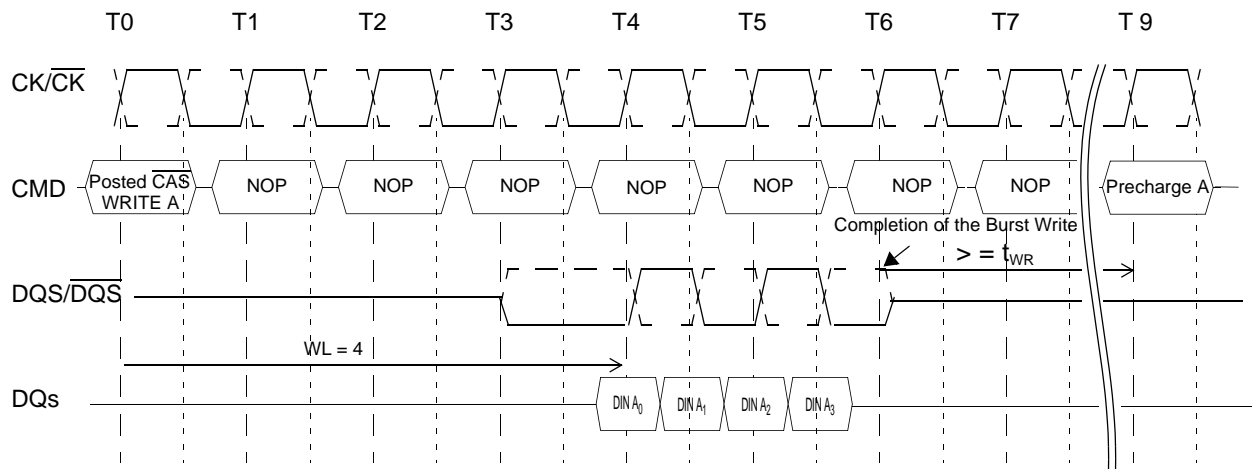

## 2.7 Auto Precharge Operation

Before a new row in an active bank can be opened, the active bank must be precharged using either the Precharge command or the auto-precharge function. When a Read or a Write command is given to the DDR2 SDRAM, the  $\overline{\text{CAS}}$  timing accepts one extra address, column address A10, to allow the active bank to automatically begin precharge at the earliest possible moment during the burst read or write cycle. If A10 is low when the READ or WRITE command is issued, then normal Read or Write burst operation is executed and the bank remains active at the completion of the burst sequence. If A10 is high when the Read or Write command is issued, then the auto-precharge function is engaged. During auto-precharge, a Read command will execute as normal with the exception that the active bank will begin to precharge on the rising edge which is  $\overline{\text{CAS}}$  latency (CL) clock cycles before the end of the read burst.

Auto-precharge is also implemented during Write commands. The precharge operation engaged by the Auto precharge command will not begin until the last data of the burst write sequence is properly stored in the memory array.

This feature allows the precharge operation to be partially or completely hidden during burst read cycles (dependent upon  $\overline{\text{CAS}}$  latency) thus improving system performance for random data access. The  $\overline{\text{RAS}}$  lockout circuit internally delays the Precharge operation until the array restore operation has been completed ( $t_{\text{RAS}}$  satisfied) so that the auto precharge command may be issued with any read or write command.

### Burst Read with Auto Precharge

If A10 is high when a Read Command is issued, the Read with Auto-Precharge function is engaged. The DDR2 SDRAM starts an Auto Precharge operation on the rising edge which is  $(AL + BL/2)$  cycles later than the read with AP command if  $t_{\text{RAS}}(\text{min})$  and  $t_{\text{RTP}}$  are satisfied.

If  $t_{\text{RAS}}(\text{min})$  is not satisfied at the edge, the start point of auto-precharge operation will be delayed until  $t_{\text{RAS}}(\text{min})$  is satisfied.

If  $t_{\text{RTP}}(\text{min})$  is not satisfied at the edge, the start point of auto-precharge operation will be delayed until  $t_{\text{RTP}}(\text{min})$  is satisfied.

In case the internal precharge is pushed out by  $t_{\text{RTP}}$ ,  $t_{\text{RP}}$  starts at the point where the internal precharge happens (not at the next rising clock edge after this event). So for  $BL = 4$  the minimum time from Read<sub>AP</sub> to the next Activate command becomes  $AL + (t_{\text{RTP}} + t_{\text{RP}})^*$  (see example 2) for  $BL = 8$  the time from Read<sub>AP</sub> to the next Activate is  $AL + 2 + (t_{\text{RTP}} + t_{\text{RP}})^*$ , where "\*" means: "rounded up to the next integer". In any event internal precharge does not start earlier than two clocks after the last 4-bit prefetch.

A new bank activate (command) may be issued to the same bank if the following two conditions are satisfied simultaneously.

- (1) The  $\overline{\text{RAS}}$  precharge time ( $t_{\text{RP}}$ ) has been satisfied from the clock at which the auto precharge begins.
- (2) The  $\overline{\text{RAS}}$  cycle time ( $t_{\text{RC}}$ ) from the previous bank activation has been satisfied.

**Example 1: Burst Read Operation with Auto Precharge:**  
**RL = 4, AL = 1, CL = 3, BL = 8,  $t_{RTP} \leq 2$  clocks**

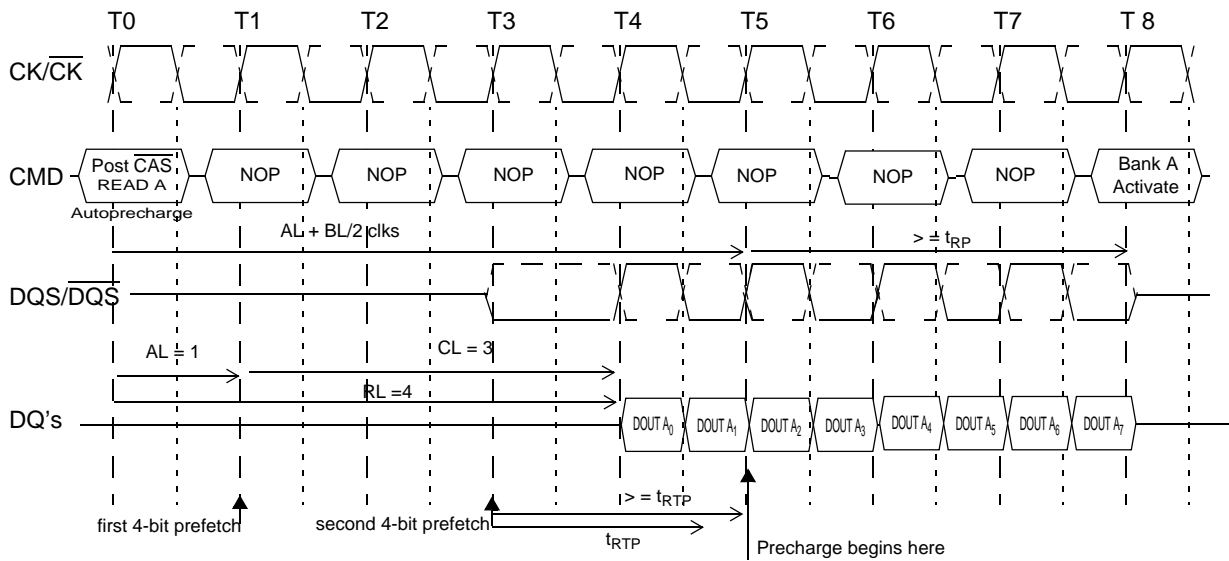

**Example 2: Burst Read Operation with Auto Precharge:**  
**RL = 4, AL = 1, CL = 3, BL = 4,  $t_{RTP} > 2$  clocks**

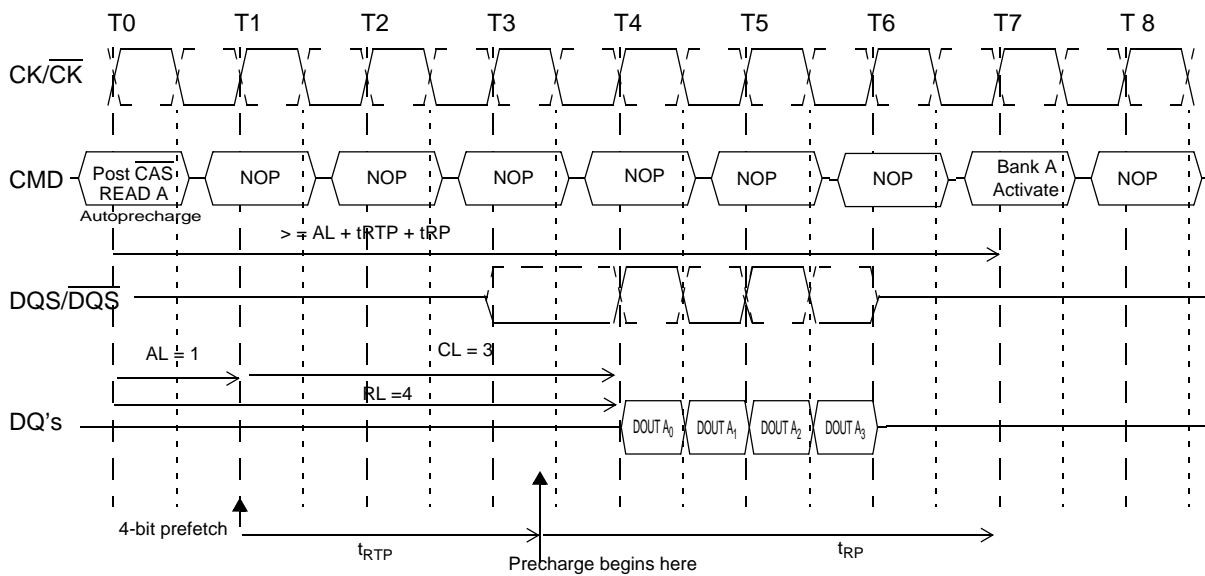

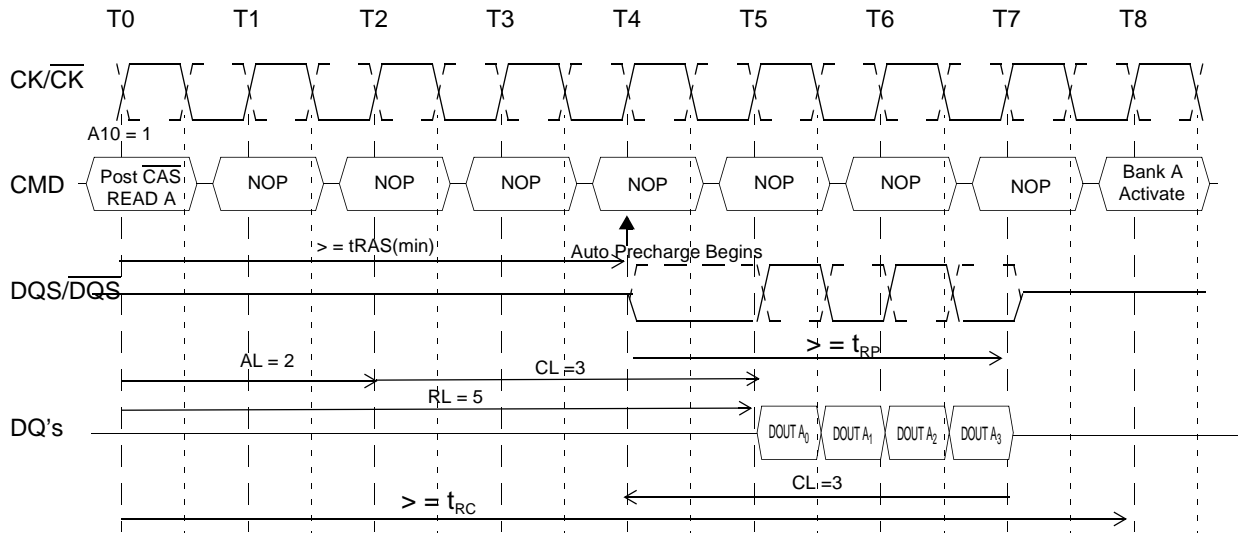
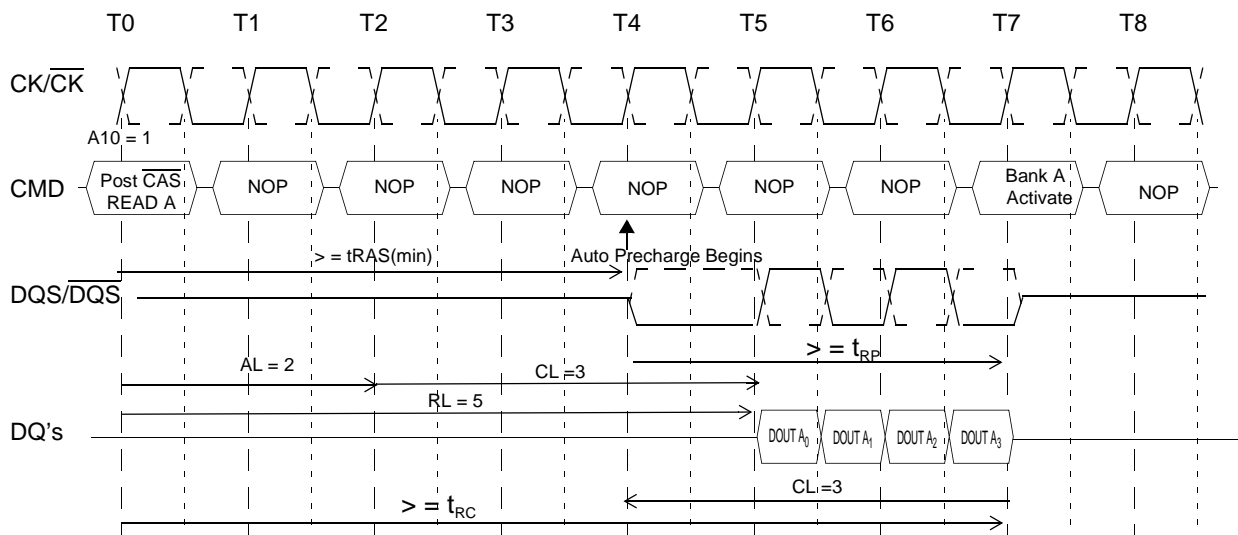
**Example 3: Burst Read with Auto Precharge Followed by an activation to the Same Bank(tRC Limit):**
**RL = 5 (AL = 2, CL = 3, internal tRCD = 3, BL = 4, t<sub>RTP</sub> <= 2 clocks)**

**Example 4: Burst Read with Auto Precharge Followed by an Activation to the Same Bank(tRP Limit):**
**RL = 5 (AL = 2, CL = 3, internal tRCD = 3, BL = 4, t<sub>RTP</sub> <= 2 clocks)**

## Burst Write with Auto-Precharge

If A10 is high when a Write Command is issued, the Write with Auto-Precharge function is engaged. The DDR2 SDRAM automatically begins precharge operation after the completion of the burst write plus write recovery time ( $t_{WR}$ ). The bank undergoing auto-precharge from the completion of the write burst may be reactivated if the following two conditions are satisfied.

- (1) The data-in to bank activate delay time ( $WR + t_{RP}$ ) has been satisfied.
- (2) The  $\overline{\text{RAS}}$  cycle time ( $t_{RC}$ ) from the previous bank activation has been satisfied.

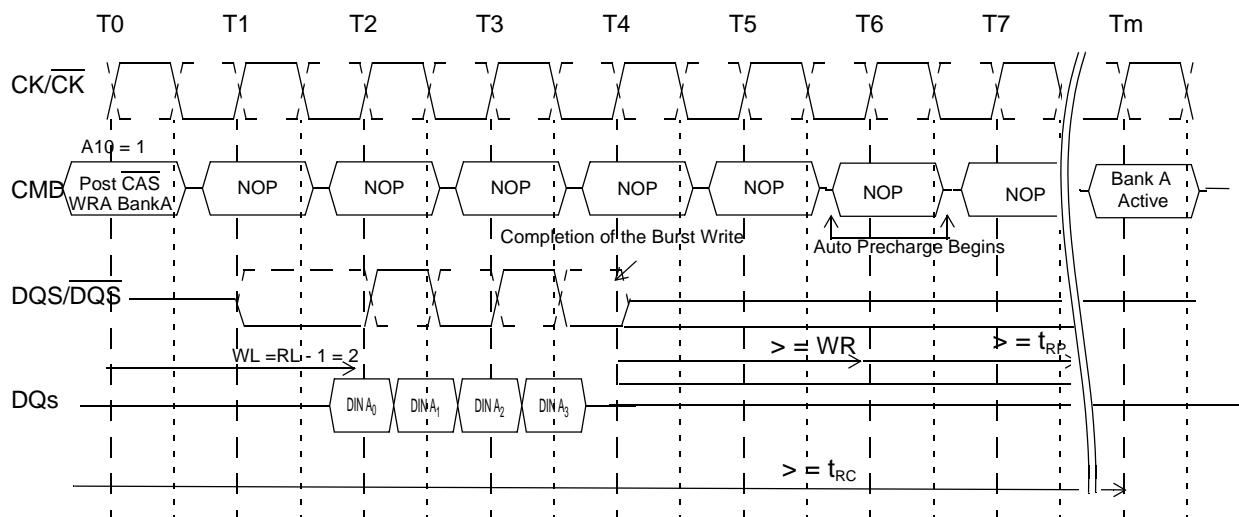
### Burst Write with Auto-Precharge ( $t_{RC}$ Limit): $WL = 2, t_{WR} = 2, BL = 4, t_{RP} = 3$



### Burst Write with Auto-Precharge ( $t_{WR} + t_{RP}$ ): $WL = 4, t_{WR} = 2, BL = 4, t_{RP} = 3$

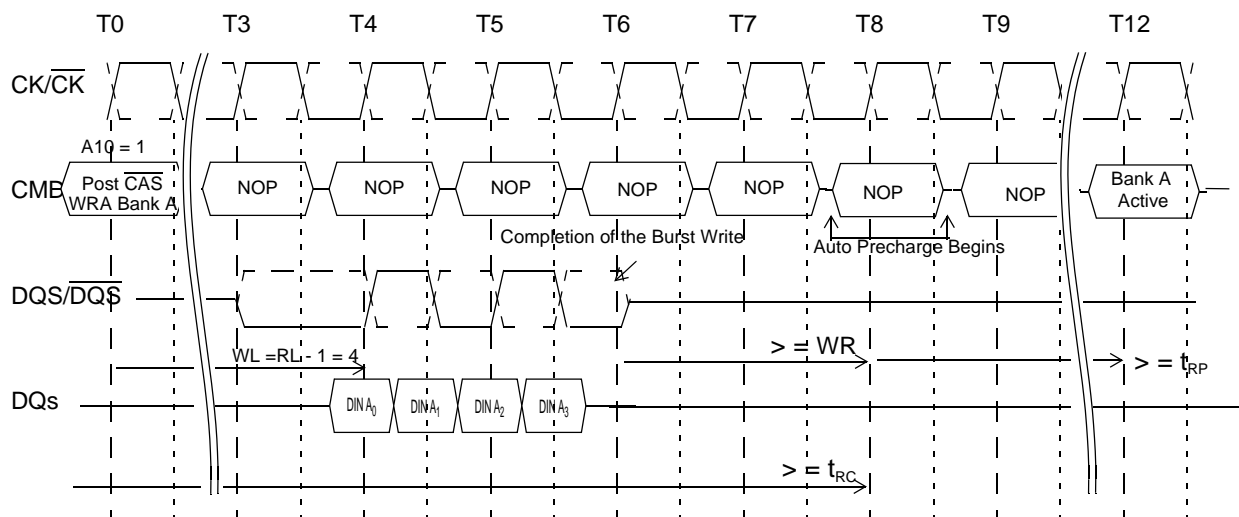

## 2.8 Refresh Commands

DDR2 SDRAMs require a refresh of all rows in any rolling 64 ms interval. Each refresh is generated in one of two ways: by an explicit Auto-Refresh command, or by an internally timed event in SELF REFRESH mode. Dividing the number of device rows into the rolling 64ms interval,  $t_{REFI}$ , which is a guideline to controllers for distributed refresh timing. For example, a 256Mb DDR2 SDRAM has 8192 rows resulting in a  $t_{REFI}$  of  $7.8\beta_j$ . To avoid excessive interruptions to the memory controller, higher density DDR2 SDRAMs maintain  $7.8\beta_j$  average refresh time and perform multiple internal refresh bursts. In these cases, the refresh recovery times,  $t_{RFC}$  and  $t_{XSNR}$  are extended to accommodate these internal operations.

### 2.8.1 Auto Refresh Command

AUTO REFRESH is used during normal operation of the DDR2 SDRAM. This command is nonpersistent, so it must be issued each time a refresh is required. The refresh addressing is generated by the internal refresh controller. This makes the address bits "Don't Care" during an AUTO REFRESH command.

When  $\overline{CS}$ ,  $\overline{RAS}$  and  $\overline{CAS}$  are held low and  $\overline{WE}$  high at the rising edge of the clock, the chip enters the Refresh mode (REF). All banks of the DDR2 SDRAM must be precharged and idle for a minimum of the Precharge time ( $t_{RP}$ ) before the Refresh command (REF) can be applied. An address counter, internal to the device, supplies the bank address during the refresh cycle. No control of the external address bus is required once this cycle has started.

When the refresh cycle has completed, all banks of the DDR2 SDRAM will be in the precharged (idle) state. A delay between the Refresh command (REF) and the next Activate command or subsequent Refresh command must be greater than or equal to the Refresh cycle time ( $t_{RFC}$ ).

To allow for improved efficiency in scheduling and switching between tasks, some flexibility in the absolute refresh interval is provided. A maximum of eight Refresh commands can be posted to any given DDR2 SDRAM, meaning that the maximum absolute interval between any Refresh command and the next Refresh command is  $9 * t_{REFI}$ .

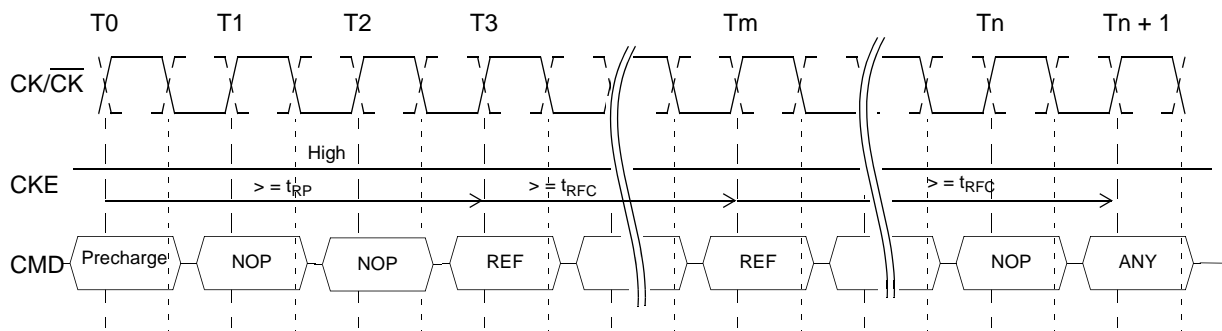

### 2.8.2 Self Refresh Operation

The Self Refresh command can be used to retain data in the DDR2 SDRAM, even if the rest of the system is powered down. When in the Self Refresh mode, the DDR2 SDRAM retains data without external clocking.

The DDR2 SDRAM device has a built-in timer to accommodate Self Refresh operation. The Self Refresh Command is defined by having  $\overline{CS}$ ,  $\overline{RAS}$ ,  $\overline{CAS}$  and CKE held low with  $\overline{WE}$  high at the rising edge of the clock. ODT must be turned off before issuing Self Refresh command, by either driving ODT pin low or using EMRS command. Once the Command is registered, CKE must be held low to keep the device in Self Refresh mode. The DLL is automatically disabled upon entering Self Refresh and is automatically enabled upon exiting Self Refresh. When the DDR2 SDRAM has entered Self Refresh mode all of the external signals except CKE, are "don't care". The DRAM initiates a minimum of one Auto Refresh command internally within  $t_{CKE}$  period once it enters Self Refresh mode. The clock is internally disabled during Self Refresh Operation to save power. The minimum time that the DDR2 SDRAM must remain in Self Refresh mode is  $t_{CKE}$ . The user may change the external clock frequency or halt the external clock one clock after Self-Refresh entry is registered, however, the clock must be restarted and stable before the device can exit Self Refresh operation.

The procedure for exiting Self Refresh requires a sequence of commands. First, the clock must be stable prior to CKE going back HIGH. Once Self Refresh Exit command is registered, a delay equal or longer than the tXSNR or tXSRD must be satisfied before a valid command can be issued to the device. CKE must remain high for the entire Self Refresh exit period tXSRD for proper operation. Upon exit from Self Refresh, the DDR2 SDRAM can be put back into Self Refresh mode after tXSRD expires. NOP or deselect commands must be registered on each positive clock edge during the Self Refresh exit interval. ODT should also be turned off during tXSRD.

The Use of Self Refresh mode introduce the possibility that an internally timed refresh event can be missed when CKE is raised for exit from Self Refresh mode. Upon exit from Self Refresh, the DDR2 SDRAM requires a minimum of one extra auto refresh command before it is put back into Self Refresh mode.

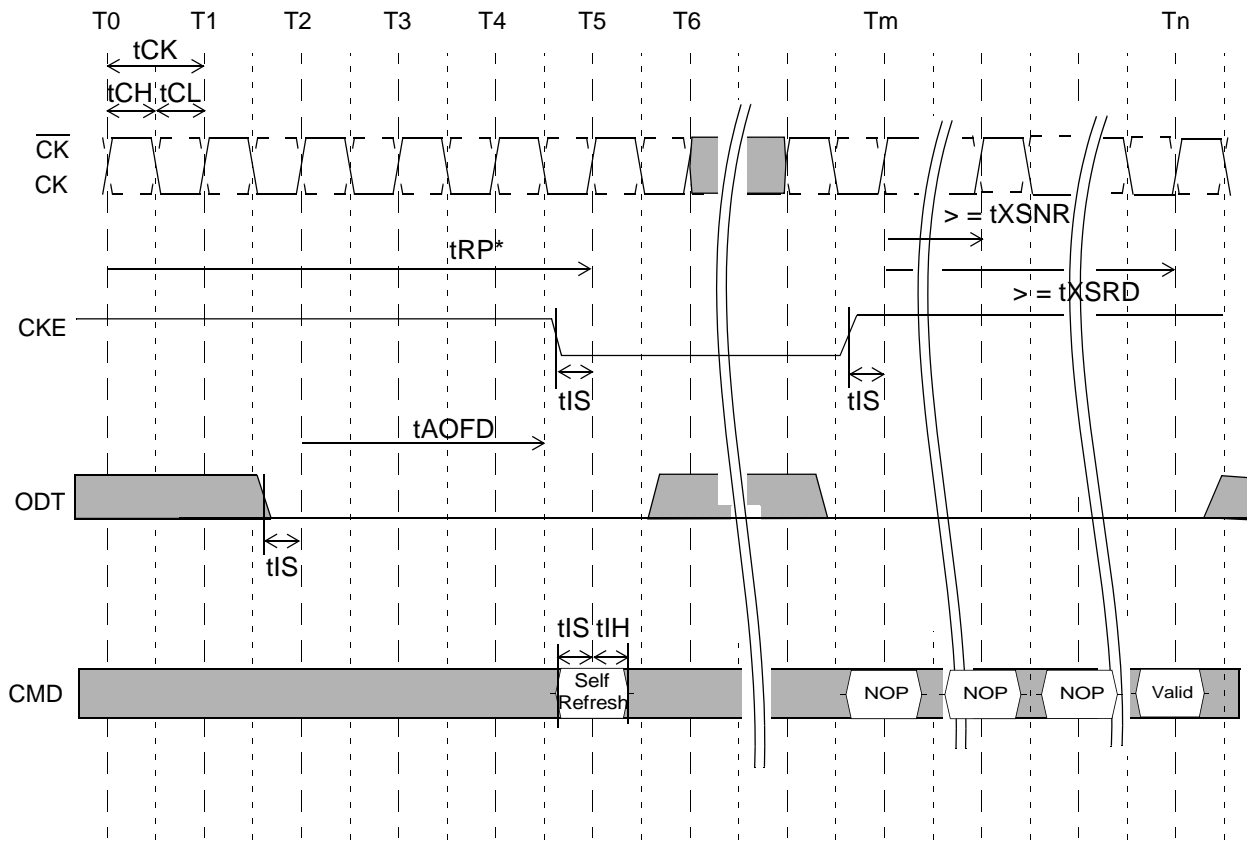

- Device must be in the "All banks idle" state prior to entering Self Refresh mode.
- ODT must be turned off tAOFD before entering Self Refresh mode, and can be turned on again when tXSRD timing is satisfied.
- tXSRD is applied for a Read or a Read with autoprecharge command
- tXSNR is applied for any command except a Read or a Read with autoprecharge command.

## 2.9 Power-Down

Power-down is synchronously entered when CKE is registered low (along with Nop or Deselect command). CKE is not allowed to go low while mode register or extended mode register command time, or read or write operation is in progress. CKE is allowed to go low while any of other operations such as row activation, precharge or autoprecharge, or auto-refresh is in progress, but power-down IDD spec will not be applied until finishing those operations. Timing diagrams are shown in the following pages with details for entry into power down.

The DLL should be in a locked state when power-down is entered. Otherwise DLL should be reset after exiting power-down mode for proper read operation.

If power-down occurs when all banks are idle, this mode is referred to as precharge power-down; if power-down occurs when there is a row active in any bank, this mode is referred to as active power-down. Entering power-down deactivates the input and output buffers, excluding CK,  $\overline{\text{CK}}$ , ODT and CKE. Also the DLL is disabled upon entering precharge power-down or slow exit active power-down, but the DLL is kept enabled during fast exit active power-down. In power-down mode, CKE low and a stable clock signal must be maintained at the inputs of the DDR2 SDRAM, and ODT should be in a valid state but all other input signals are "Don't Care". CKE low must be maintained until  $t_{\text{CKE}}$  has been satisfied. Power-down duration is limited by 9 times  $t_{\text{REFI}}$  of the device.

The power-down state is synchronously exited when CKE is registered high (along with a Nop or Deselect command). CKE high must be maintained until  $t_{\text{CKE}}$  has been satisfied. A valid, executable command can be applied with power-down exit latency,  $t_{\text{XP}}$ ,  $t_{\text{XARD}}$ , or  $t_{\text{XARDS}}$ , after CKE goes high. Power-down exit latency is defined at AC spec table of this data sheet.

### Basic Power Down Entry and Exit timing diagram

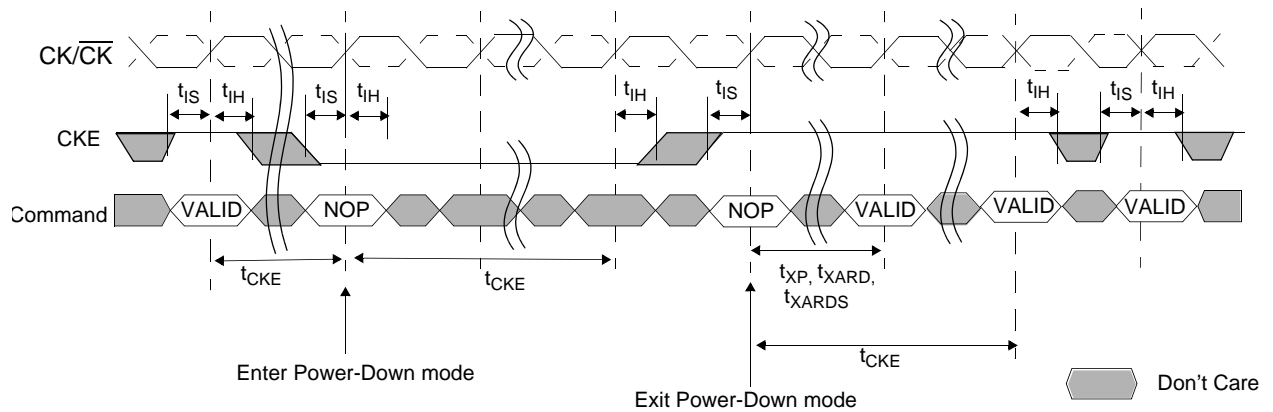

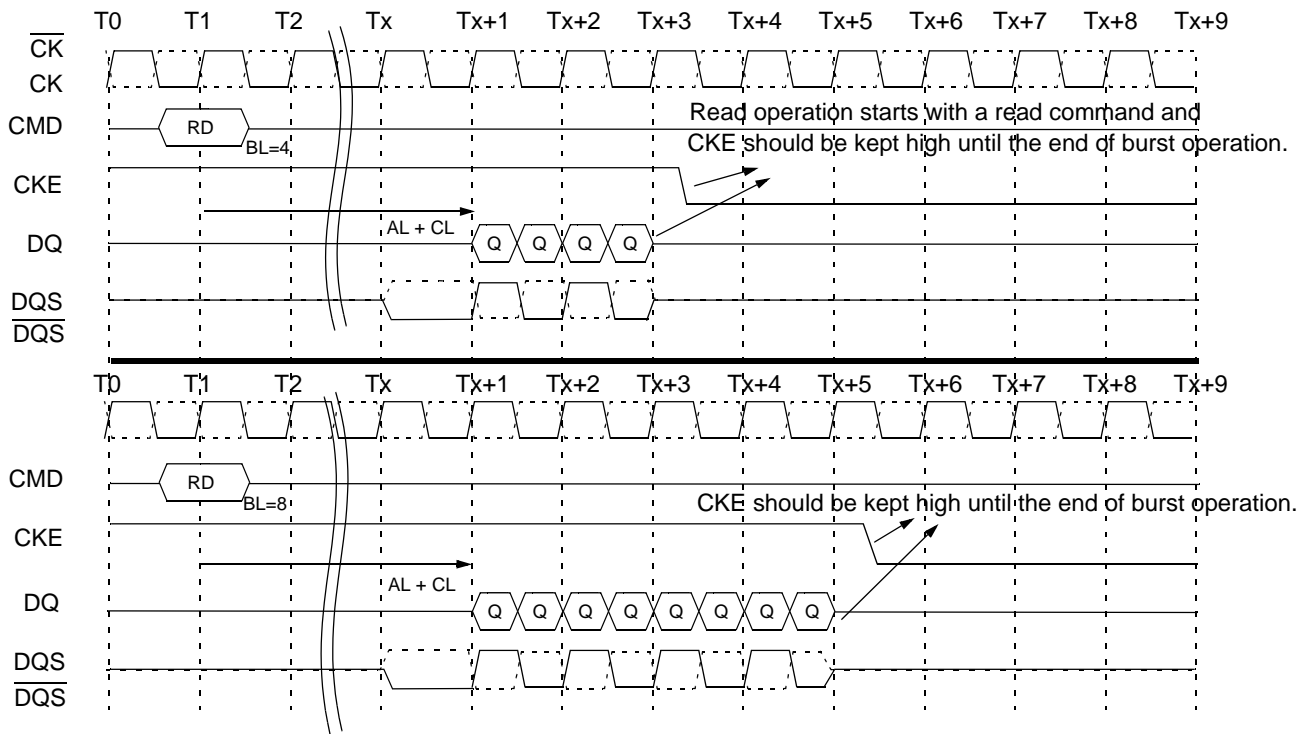
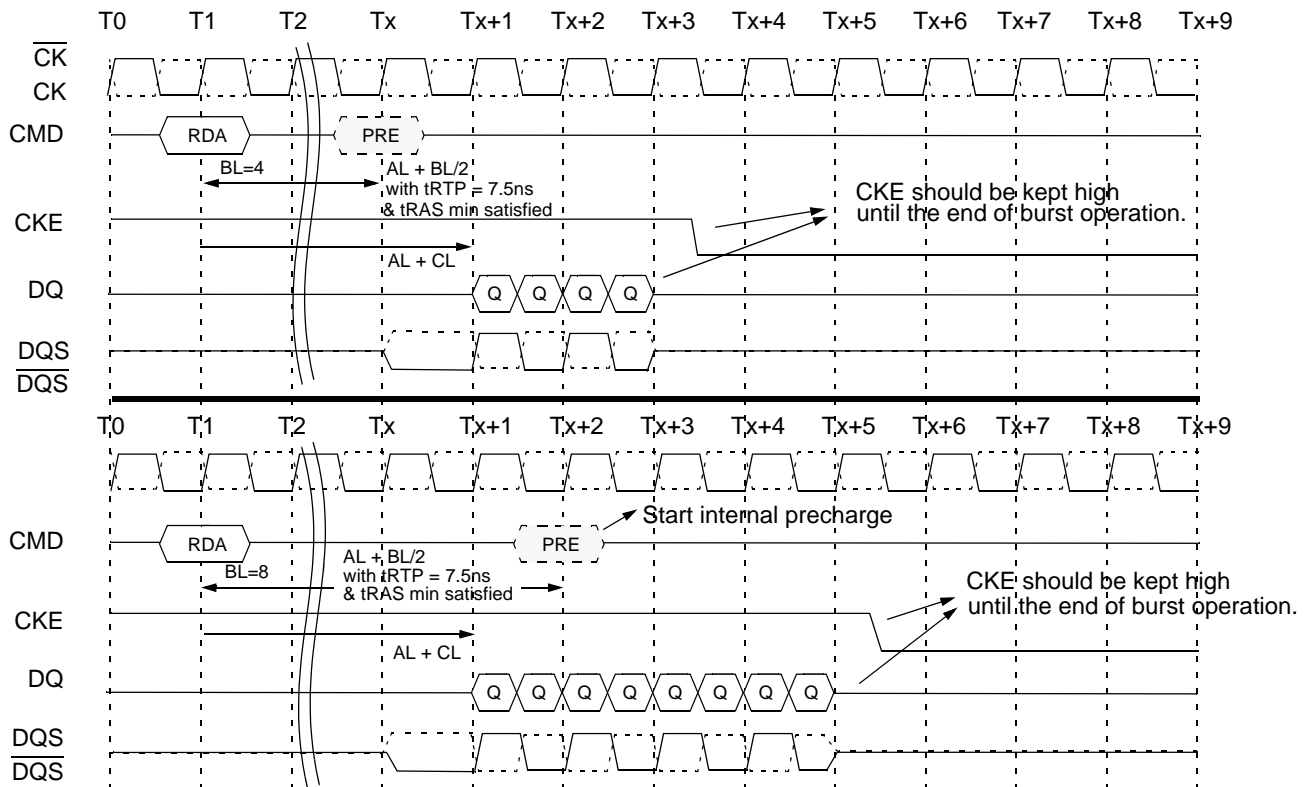
**Read to power down entry**

**Read with Autoprecharge to power down entry**

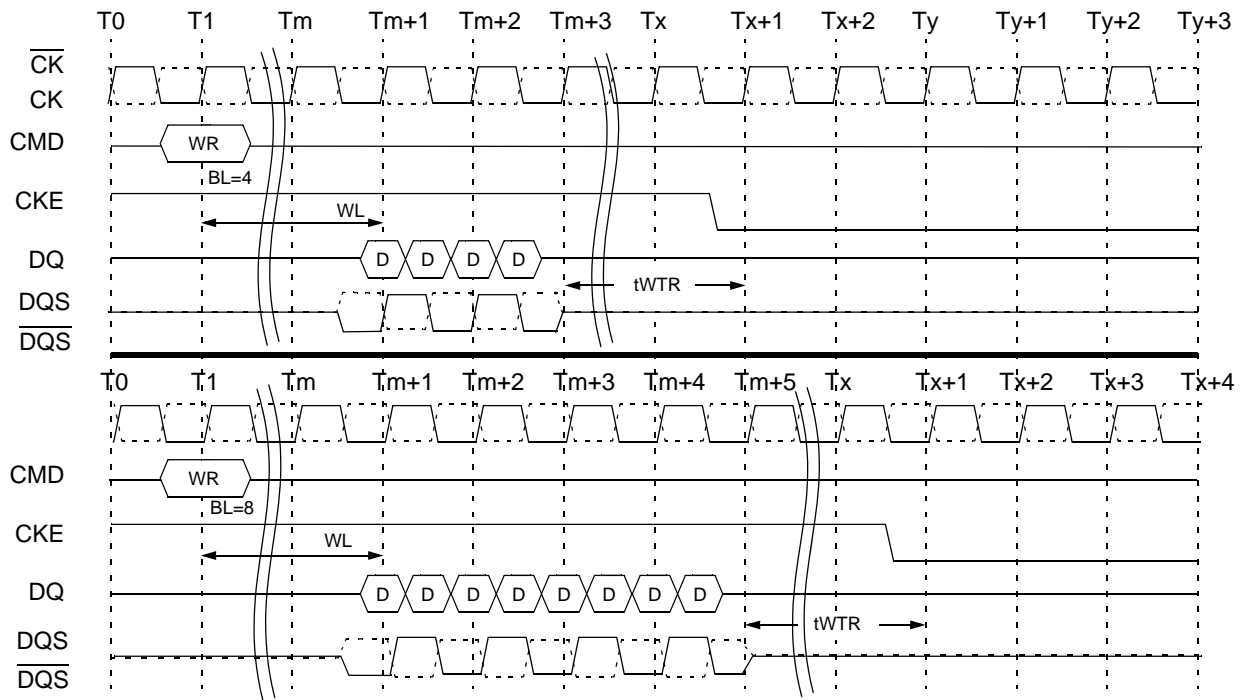
**Write to power down entry**

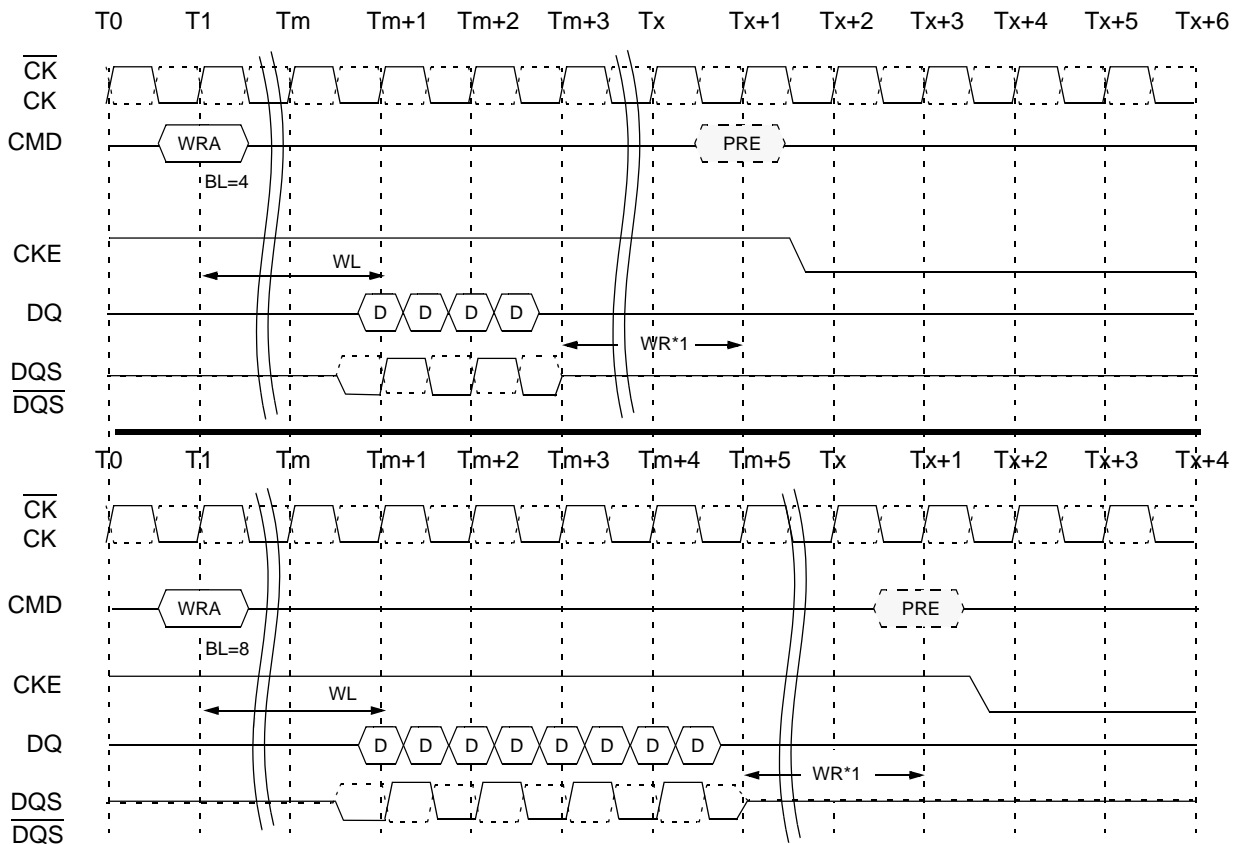

**Write with Autoprecharge to power down entry**



\* 1: WR is programmed through MRS

**Refresh command to power down entry**

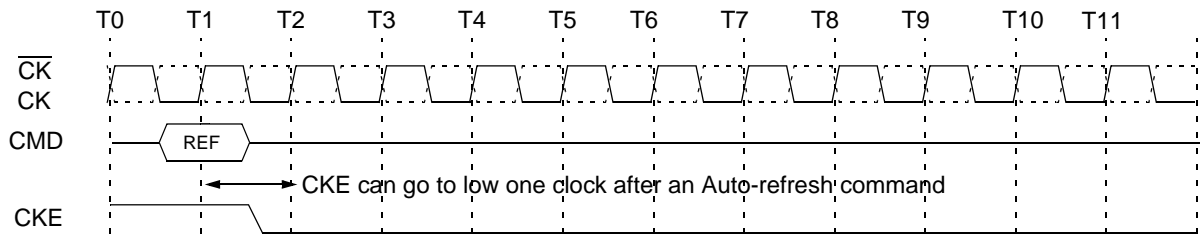

**Active command to power down entry**

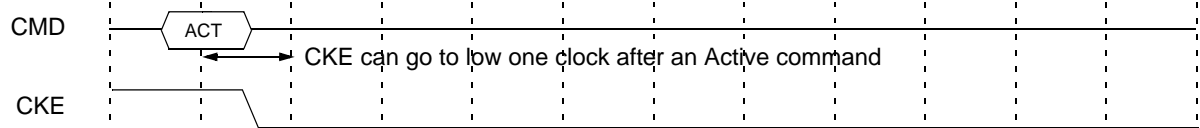

**Precharge/Precharge all command to power down entry**

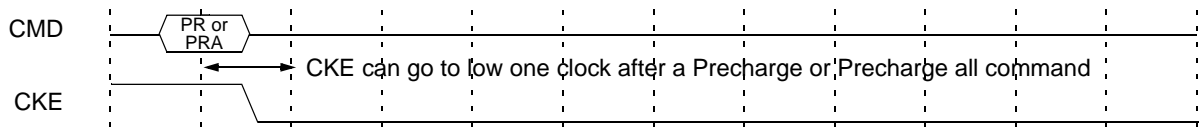

**MRS/EMRS command to power down entry**

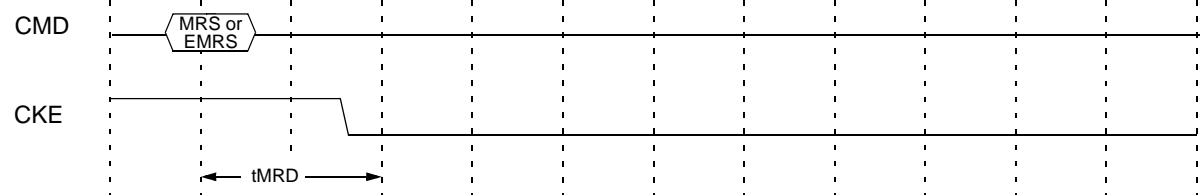

## 2. 10 Asynchronous CKE Low Event

DRAM requires CKE to be maintained "HIGH" for all valid operations as defined in this data sheet. If CKE asynchronously drops "LOW" during any valid operation DRAM is not guaranteed to preserve the contents of array. If this event occurs, memory controller must satisfy DRAM timing specification  $t_{Delay}$  before turning off the clocks. Stable clocks must exist at the input of DRAM before CKE is raised "HIGH" again. DRAM must be fully re-initialized (steps 4 thru 13) as described in initialization sequence. DRAM is ready for normal operation after the initialization sequence. See AC timing parametric table for  $t_{Delay}$  specification

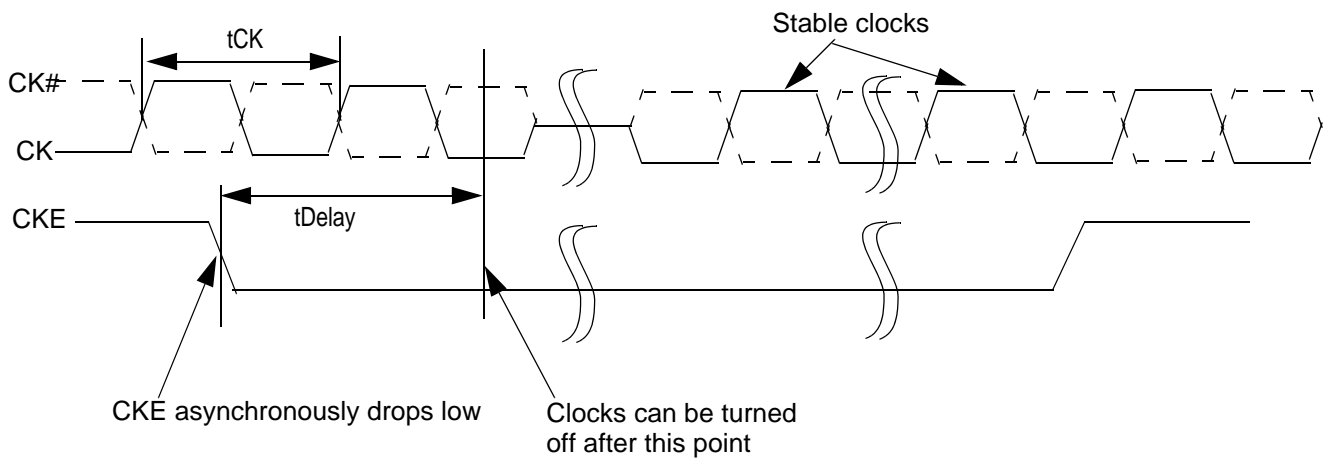

## Input Clock Frequency Change during Precharge Power Down

DDR2 SDRAM input clock frequency can be changed under following condition:

DDR2 SDRAM is in precharged power down mode. ODT must be turned off and CKE must be at logic LOW level. A minimum of 2 clocks must be waited after CKE goes LOW before clock frequency may change. SDRAM input clock frequency is allowed to change only within minimum and maximum operating frequency specified for the particular speed grade. During input clock frequency change, ODT and CKE must be held at stable LOW levels. Once input clock frequency is changed, stable new clocks must be provided to DRAM before precharge power down may be exited and DLL must be RESET via EMRS after precharge power down exit. Depending on new clock frequency an additional MRS command may need to be issued to appropriately set the WR, CL etc.. During DLL re-lock period, ODT must remain off. After the DLL lock time, the DRAM is ready to operate with new clock frequency.

### Clock Frequency Change in Precharge Power Down Mode

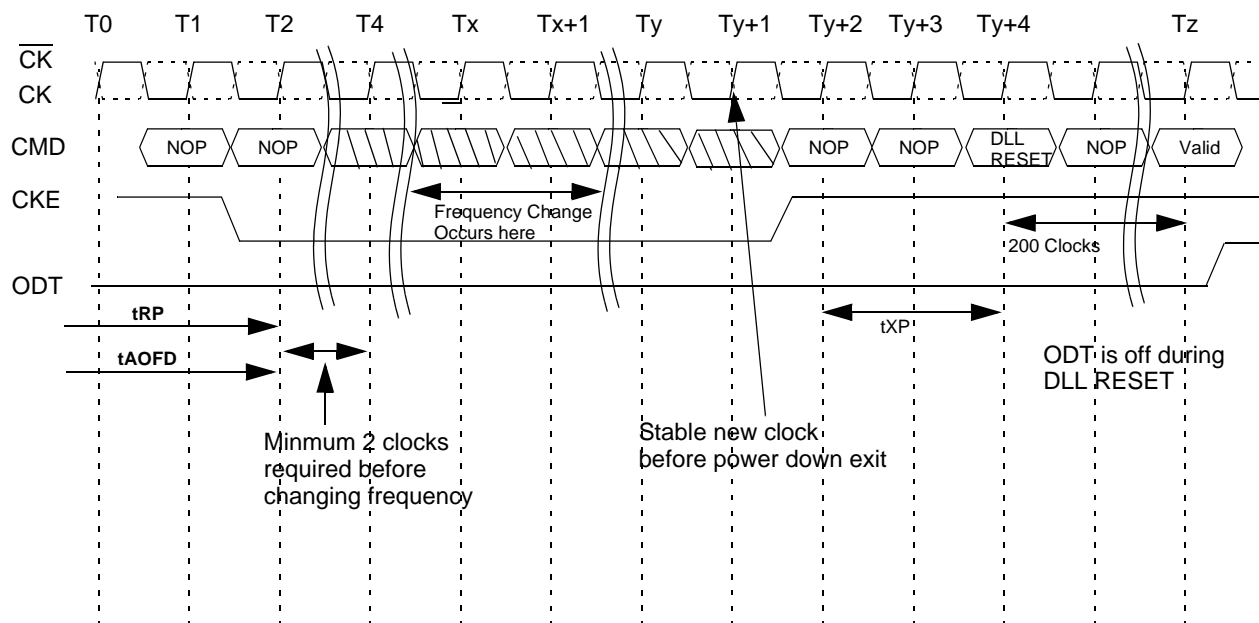

## 2.11 No Operation Command

The No Operation command should be used in cases when the DDR2 SDRAM is in an idle or a wait state. The purpose of the No Operation command (NOP) is to prevent the DDR2 SDRAM from registering any unwanted commands between operations. A No Operation command is registered when  $\overline{CS}$  is low with  $\overline{RAS}$ ,  $\overline{CAS}$ , and  $\overline{WE}$  held high at the rising edge of the clock. A No Operation command will not terminate a previous operation that is still executing, such as a burst read or write cycle.

## 2.12 Deselect Command

The Deselect command performs the same function as a No Operation command. Deselect command occurs when  $\overline{CS}$  is brought high at the rising edge of the clock, the  $\overline{RAS}$ ,  $\overline{CAS}$ , and  $\overline{WE}$  signals become don't cares.

### 3. Truth Tables

#### 3.1 Command truth table.

Function	CKE		$\overline{\text{CS}}$	$\overline{\text{RAS}}$	$\overline{\text{CAS}}$	$\overline{\text{WE}}$	BA0 BA1	A15-A11	A10	A9 - A0	Notes
	Previous Cycle	Current Cycle									
(Extended) Mode Register Set	H	H	L	L	L	L	BA	OP Code			1,2
Refresh (REF)	H	H	L	L	L	H	X	X	X	X	1
Self Refresh Entry	H	L	L	L	L	H	X	X	X	X	1
Self Refresh Exit	L	H	H	X	X	X	X	X	X	X	1,7
			L	H	H	H					
Single Bank Precharge	H	H	L	L	H	L	BA	X	L	X	1,2
Precharge all Banks	H	H	L	L	H	L	X	X	H	X	1
Bank Activate	H	H	L	L	H	H	BA	Row Address			1,2
Write	H	H	L	H	L	L	BA	Column	L	Column	1,2,3,
Write with Auto Precharge	H	H	L	H	L	L	BA	Column	H	Column	1,2,3,
Read	H	H	L	H	L	H	BA	Column	L	Column	1,2,3
Read with Auto-Precharge	H	H	L	H	L	H	BA	Column	H	Column	1,2,3
No Operation	H	X	L	H	H	H	X	X	X	X	1
Device Deselect	H	X	H	X	X	X	X	X	X	X	1
Power Down Entry	H	L	H	X	X	X	X	X	X	X	1,4
			L	H	H	H					
Power Down Exit	L	H	H	X	X	X	X	X	X	X	1,4
			L	H	H	H					

1. All DDR2 SDRAM commands are defined by states of CS, RAS, CAS, WE and CKE at the rising edge of the clock.
2. Bank addresses BA0, BA1(BA) determine which bank is to be operated upon. For (E)MRS BA selects an (Extended) Mode Register.
3. Burst reads or writes at BL=4 cannot be terminated or interrupted. See sections "Reads interrupted by a Read" and "Writes interrupted by a Write" in section 2.2.4 for details.
4. The Power Down Mode does not perform any refresh operations. The duration of Power Down is therefore limited by the refresh requirements outlined in section 2.2.7.
5. The state of ODT does not affect the states described in this table. The ODT function is not available during Self Refresh. See section 2.2.2.4.
6. "X" means "H or L (but a defined logic level)".
7. Self refresh exit is asynchronous.

### 3.2 Clock Enable (CKE) Truth Table for Synchronous Transitions

Current State <sup>2</sup>	CKE		Command (N) <sup>3</sup> $\overline{\text{RAS}}, \overline{\text{CAS}}, \overline{\text{WE}}, \overline{\text{CS}}$	Action (N) <sup>3</sup>	Notes
	Previous Cycle <sup>1</sup> (N-1)	Current Cycle <sup>1</sup> (N)			
Power Down	L	L	X	Maintain Power-Down	11, 13, 15
	L	H	DESELECT or NOP	Power Down Exit	4, 8, 11,13
Self Refresh	L	L	X	Maintain Self Refresh	11, 15
	L	H	DESELECT or NOP	Self Refresh Exit	4, 5,9
Bank(s) Active	H	L	DESELECT or NOP	Active Power Down Entry	4,8,10,11,13
All Banks Idle	H	L	DESELECT or NOP	Precharge Power Down Entry	4, 8, 10,11,13
	H	L	REFRESH	Self Refresh Entry	6, 9, 11,13
	H	H	Refer to the Command Truth Table		7

Notes:

1. CKE (N) is the logic state of CKE at clock edge N; CKE (N-1) was the state of CKE at the previous clock edge.
2. Current state is the state of the DDR SDRAM immediately prior to clock edge N.
3. COMMAND (N) is the command registered at clock edge N, and ACTION (N) is a result of COMMAND (N).
4. All states and sequences not shown are illegal or reserved unless explicitly described elsewhere in this document.
5. On Self Refresh Exit DESELECT or NOP commands must be issued on every clock edge occurring during the  $t_{\text{XSNR}}$  period. Read commands may be issued only after  $t_{\text{XSRD}}$  (200 clocks) is satisfied.
6. Self Refresh mode can only be entered from the All Banks Idle state.
7. Must be a legal command as defined in the Command Truth Table.
8. Valid commands for Power Down Entry and Exit are NOP and DESELECT only.
9. Valid commands for Self Refresh Exit are NOP and DESELECT only.
10. Power Down and Self Refresh can not be entered while Read or Write operations, (Extended) Mode Register Set operations or Precharge operations are in progress. See section 2.2.9 "Power Down" and 2.2.8 "Self Refresh Command" for a detailed list of restrictions.
11. Minimum CKE high time is three clocks.; minimum CKE low time is three clocks.
12. The state of ODT does not affect the states described in this table. The ODT function is not available during Self Refresh. See section 2.2.2.4.
13. The Power Down does not perform any refresh operations. The duration of Power Down Mode is therefore limited by the refresh requirements outlined in section 2.2.7.
14. CKE must be maintained high while the SDRAM is in OCD calibration mode .
15. "X" means "don't care (including floating around VREF)" in Self Refresh and Power Down. However ODT must be driven high or low in Power Down if the ODT function is enabled (Bit A2 or A6 set to "1" in EMRS(1) ).

### 3.3 Data Mask Truth Table

Name (Functional)	DM	DQs	Note
Write enable	L	Valid	1
Write inhibit	H	X	1
1. Used to mask write data, provided coincident with the corresponding data			

## 4. Operating Conditions

### 4.1 Absolute Maximum DC Ratings

Symbol	Parameter	Rating	Units	Notes
VDD	Voltage on VDD pin relative to Vss	- 1.0 V ~ 2.3 V	V	1
VDDQ	Voltage on VDDQ pin relative to Vss	- 0.5 V ~ 2.3 V	V	1
VDDL	Voltage on VDDL pin relative to Vss	- 0.5 V ~ 2.3 V	V	1
V <sub>IN</sub> , V <sub>OUT</sub>	Voltage on any pin relative to Vss	- 0.5 V ~ 2.3 V	V	1
T <sub>STG</sub>	Storage Temperature	-55 to +100	°C	1

- Stresses greater than those listed under "Absolute Maximum Ratings" may cause permanent damage to the device. This is a stress rating only and functional operation of the device at these or any other conditions above those indicated in the operational sections of this specification is not implied. Exposure to absolute maximum rating conditions for extended periods may affect reliability.

### 4.2 Operating Temperature Condition

Symbol	Parameter	Rating	Units	Notes
T <sub>oper</sub>	Operating Temperature	0 to 85	°C	1,2

- Operating Temperature is the case surface temperature on the center/top side of the DRAM. For the measurement conditions, please refer to JESD51-2 standard.
- The operating temperature range are the temperature where all DRAM specification will be supported. Outside of this temperature range, even it is still within the limit of stress condition, some deviation on portion of operation specification may be required. During operation, the DRAM case temperature must be maintained between 0 ~ 85°C under all other specification parameters. However, in some applications, it is desirable to operate the DRAM up to 95°C case temperature. Therefore 2 spec options may exist.
  - Supporting 0 - 85°C with full JEDEC AC & DC specifications. This is the minimum requirements for all operating temperature options.
  - Supporting 0 - 85°C and being able to extend to 95°C with doubling auto-refresh commands in frequency to a 32 ms period( $t_{RFI}=3.9\beta_j$ ).

Note; Self-refresh period within the above DRAM is hard coded at 64ms( $t_{REFI}= 7.8\beta_j$ ). Therefore, it is imperative that the system ensures the DRAM is at or below 85°C case temperature before initiating self-refresh operation.

## 5. AC & DC Operating Conditions

### 5.1 DC Operation Conditions

#### 5.1.1 Recommended DC Operating Conditions (SSTL\_1.8)

Symbol	Parameter	Rating			Units	Notes
		Min.	Typ.	Max.		
VDD	Supply Voltage	1.7	1.8	2.1	V	5
VDDL	Supply Voltage for DLL	1.7	1.8	2.1	V	4, 5
VDDQ	Supply Voltage for Output	1.7	1.8	2.1	V	4, 5
VREF	Input Reference Voltage	0.49*VDDQ	0.50*VDDQ	0.51*VDDQ	mV	1, 2
VTT	Termination Voltage	VREF-0.04	VREF	VREF+0.04	V	3

There is no specific device VDD supply voltage requirement for SSTL-1.8 compliance. However under all conditions VDDQ must be less than or equal to VDD.

1. The value of VREF may be selected by the user to provide optimum noise margin in the system. Typically the value of VREF is expected to be about 0.5 x VDDQ of the transmitting device and VREF is expected to track variations in VDDQ.
2. Peak to peak ac noise on VREF may not exceed +/-2% VREF (dc).
3. VTT of transmitting device must track VREF of receiving device.
4. VDDQ tracks with VDD, VDDL tracks with VDD. AC parameters are measured with VDD, VDDQ and VDDL tied together
5. 500/450/400/350Mhz support

#### 5.1.2 ODT DC electrical characteristics

PARAMETER/CONDITION	SYMBOL	MIN	NOM	MAX	UNITS	NOTES
Rtt effective impedance value for EMRS(A6,A2)=0,1; 75 ohm	Rtt1(eff)	60	75	90	ohm	1
Rtt effective impedance value for EMRS(A6,A2)=1,0; 150 ohm	Rtt2(eff)	120	150	180	ohm	1
Rtt effective impedance value for EMRS(A6, A12)=1,1 ; 50ohm	Rtt3(eff)	40	50	60	ohm	1
Deviation of VM with respect to VDDQ/2	delta VM	-6		6	%	1

**Note 1:** Test condition for Rtt measurements

Measurement Definition for Rtt(eff): Apply  $V_{IH}$  (ac) and  $V_{IL}$  (ac) to test pin separately, then measure current  $I(V_{IH}$  (ac)) and  $I(V_{IL}$  (ac)) respectively.  $V_{IH}$  (ac),  $V_{IL}$  (ac), and VDDQ values defined in SSTL\_18

$$R_{tt}(\text{eff}) = \frac{V_{IH}(\text{ac}) - V_{IL}(\text{ac})}{I(V_{IH}(\text{ac})) - I(V_{IL}(\text{ac}))}$$

Measurement Definition for VM : Measurement Voltage at test pin(mid point) with no load.

$$\text{delta VM} = \left( \frac{2 \times V_m}{V_{DDQ}} - 1 \right) \times 100\%$$

## 5.2 DC & AC Logic Input Levels

### 5.2.1 Input DC Logic Level

Symbol	Parameter	Min.	Max.	Units	Notes
$V_{IH(dc)}$	dc input logic high	$V_{REF} + 0.125$	+ 0.3	V	
$V_{IL(dc)}$	dc input logic low	- 0.3	$V_{REF} - 0.125$	V	

### 5.2.2 Input AC Logic Level

Symbol	Parameter	Min.	Max.	Units	Notes
$V_{IH(ac)}$	ac input logic high	$V_{REF} + 0.250$	-	V	1
$V_{IL(ac)}$	ac input logic low	-	$V_{REF} - 0.250$	V	1

**Notes :**

1. Supports 500/450/400/350MHz at 1.8V

### 5.2.3 AC Input Test Conditions

Symbol	Condition	Value	Units	Notes
$V_{REF}$	Input reference voltage	$0.5 * V_{DDQ}$	V	1
$V_{SWING(MAX)}$	Input signal maximum peak to peak swing	1.0	V	1
SLEW	Input signal minimum slew rate	1.0	V/ns	2, 3

**Notes:**

1. Input waveform timing is referenced to the input signal crossing through the  $V_{REF}$  level applied to the device under test.
2. The input signal minimum slew rate is to be maintained over the range from  $V_{IL(dc)}$  max to  $V_{IH(ac)}$  min for rising edges and the range from  $V_{IH(dc)}$  min to  $V_{IL(ac)}$  max for falling edges as shown in the below figure.
3. AC timings are referenced with input waveforms switching from  $V_{IL(ac)}$  to  $V_{IH(ac)}$  on the positive transitions and  $V_{IH(ac)}$  to  $V_{IL(ac)}$  on the negative transitions.

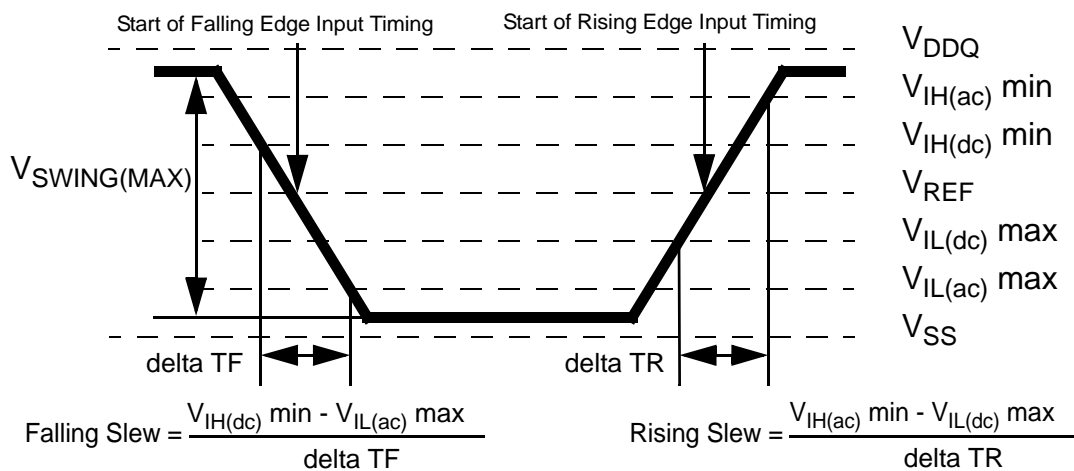

< Figure : AC Input Test Signal Waveform >

### 5.2.4 Differential Input AC logic Level

Symbol	Parameter	Min.	Max.	Units	Notes
$V_{ID}(ac)$	ac differential input voltage	0.5	$V_{DDQ} + 0.6$	V	1
$V_{IX}(ac)$	ac differential cross point voltage	$0.5 * V_{DDQ} - 0.175$	$0.5 * V_{DDQ} + 0.175$	V	2

1.  $V_{IN}(DC)$  specifies the allowable DC execution of each input of differential pair such as  $\overline{CK}$ ,  $\overline{DQS}$ ,  $\overline{LDQS}$ ,  $\overline{UDQS}$  and  $\overline{UDQS}$ .

2.  $V_{ID}(DC)$  specifies the input differential voltage  $|V_{TR} - V_{CP}|$  required for switching, where  $V_{TR}$  is the true input (such as  $\overline{CK}$ ,  $\overline{DQS}$ ,  $\overline{LDQS}$  or  $\overline{UDQS}$ ) level and  $V_{CP}$  is the complementary input (such as  $\overline{CK}$ ,  $\overline{DQS}$ ,  $\overline{LDQS}$  or  $\overline{UDQS}$ ) level. The minimum value is equal to  $V_{IH}(DC) - V_{IL}(DC)$ .

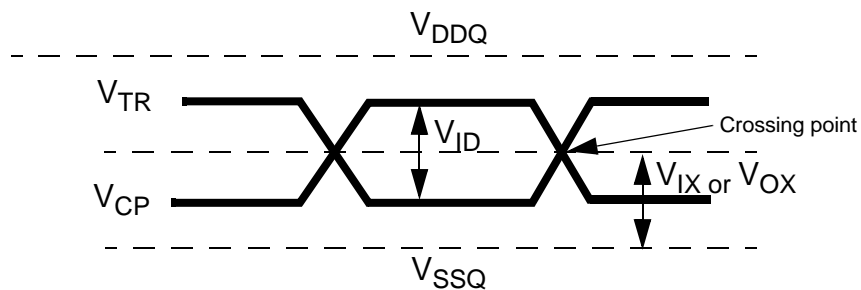

< Differential signal levels >

**Notes:**

1.  $V_{ID}(AC)$  specifies the input differential voltage  $|V_{TR} - V_{CP}|$  required for switching, where  $V_{TR}$  is the true input signal (such as  $\overline{CK}$ ,  $\overline{DQS}$ ,  $\overline{LDQS}$  or  $\overline{UDQS}$ ) and  $V_{CP}$  is the complementary input signal (such as  $\overline{CK}$ ,  $\overline{DQS}$ ,  $\overline{LDQS}$  or  $\overline{UDQS}$ ). The minimum value is equal to  $V_{IH}(AC) - V_{IL}(AC)$ .

2. The typical value of  $V_{IX}(AC)$  is expected to be about  $0.5 * V_{DDQ}$  of the transmitting device and  $V_{IX}(AC)$  is expected to track variations in  $V_{DDQ}$ .  $V_{IX}(AC)$  indicates the voltage at which differential input signals must cross.

### 5.2.5 Differential AC output parameters

Symbol	Parameter	Min.	Max.	Units	Notes
$V_{OX}(ac)$	ac differential cross point voltage	$0.5 * V_{DDQ} - 0.125$	$0.5 * V_{DDQ} + 0.125$	V	1

**Notes:**

1. The typical value of  $V_{OX}(AC)$  is expected to be about  $0.5 * V_{DDQ}$  of the transmitting device and  $V_{OX}(AC)$  is expected to track variations in  $V_{DDQ}$ .  $V_{OX}(AC)$  indicates the voltage at which differential output signals must cross.

## 5.2.6 Overshoot/Undershoot Specification

AC Overshoot/Undershoot Specification for Address and Control Pins A0-A15, BA0-BA1,  $\overline{\text{CS}}$ ,  $\overline{\text{RAS}}$ ,  $\overline{\text{CAS}}$ ,  $\overline{\text{WE}}$ , CKE, ODT

Parameter	Specification
Maximum peak amplitude allowed for overshoot area (See Figure 1):	0.9V
Maximum peak amplitude allowed for undershoot area (See Figure 1):	0.9V
Maximum overshoot area above VDD (See Figure1).	0.45 V-ns
Maximum undershoot area below VSS (See Figure 1).	0.45 V-ns

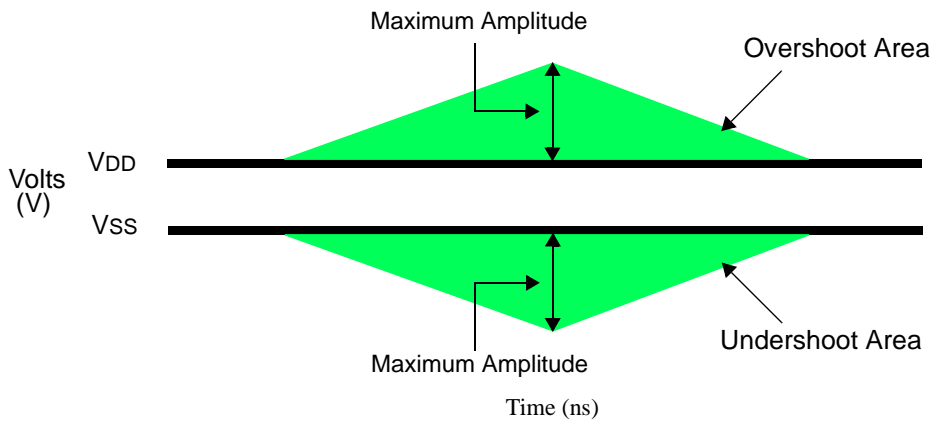

Figure 1: AC Overshoot and Undershoot Definition for Address and Control Pins

AC Overshoot/Undershoot Specification for Clock, Data, Strobe, and Mask Pins DQ, DQS, DM, CK, CK

Parameter	Specification
Maximum peak amplitude allowed for overshoot area (See Figure 2):	0.9V
Maximum peak amplitude allowed for undershoot area (See Figure 2):	0.9V
Maximum overshoot area above VDDQ (See Figure 2).	0.23 V-ns
Maximum undershoot area below VSSQ (See Figure 2).	0.23 V-ns

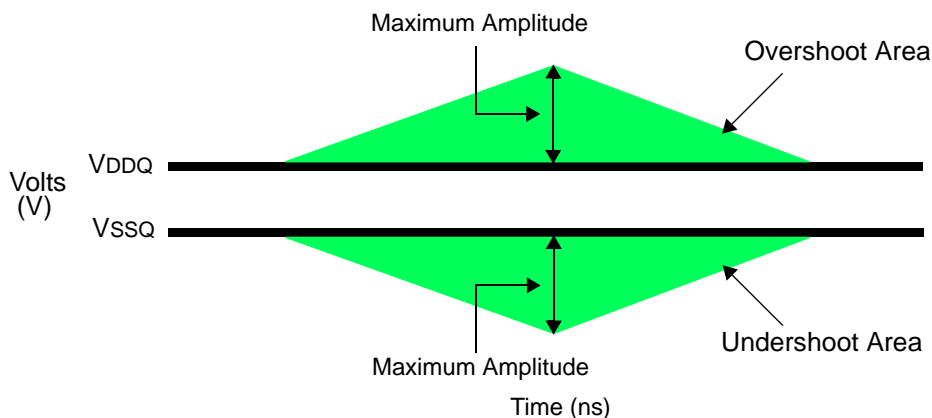

Figure 2: AC Overshoot and Undershoot Definition for Clock, Data, Strobe, and Mask Pins

Power and ground clamps are required on the following input only pins:

1. BA0-BA1
2. A0-A15
3.  $\overline{\text{RAS}}$
4.  $\overline{\text{CAS}}$
5.  $\overline{\text{WE}}$
6.  $\overline{\text{CS}}$
7. ODT
8. CKE

V-I Characteristics table for input only pins with clamps

Voltage across clamp(V)	Minimum Power Clamp Current (mA)	Minimum Ground Clamp Current (mA)
0.0	0	0
0.1	0	0
0.2	0	0
0.3	0	0
0.4	0	0
0.5	0	0
0.6	0	0
0.7	0	0
0.8	0.1	0.1
0.9	1.0	1.0
1.0	2.5	2.5
1.1	4.7	4.7
1.2	6.8	6.8
1.3	9.1	9.1
1.4	11.0	11.0
1.5	13.5	13.5
1.6	16.0	16.0
1.7	18.2	18.2
1.8	21.0	21.0

## 5.3 Output Buffer Levels

### 5.3.1 Output AC Test Conditions

Symbol	Parameter	SSTL_18 Class II	Units	Notes
$V_{OH}$	Minimum Required Output Pull-up under AC Test Load	$V_{TT} + 0.603$	V	
$V_{OL}$	Maximum Required Output Pull-down under AC Test Load	$V_{TT} - 0.603$	V	
$V_{OTR}$	Output Timing Measurement Reference Level	$0.5 * V_{DDQ}$	V	1

1. The VDDQ of the device under test is referenced.

### 5.3.2 Output DC Current Drive

Symbol	Parameter	SSTL_18 Class II	Units	Notes
$I_{OH(dc)}$	Output Minimum Source DC Current	- 13.4	mA	1, 3, 4
$I_{OL(dc)}$	Output Minimum Sink DC Current	13.4	mA	2, 3, 4

- $V_{DDQ} = 1.7\text{ V}$ ;  $V_{OUT} = 1420\text{ mV}$ .  $(V_{OUT} - V_{DDQ})/I_{OH}$  must be less than 21 ohm for values of  $V_{OUT}$  between  $V_{DDQ}$  and  $V_{DDQ} - 280\text{ mV}$ .
- $V_{DDQ} = 1.7\text{ V}$ ;  $V_{OUT} = 280\text{ mV}$ .  $V_{OUT}/I_{OL}$  must be less than 21 ohm for values of  $V_{OUT}$  between 0 V and 280 mV.
- The dc value of  $V_{REF}$  applied to the receiving device is set to  $V_{TT}$
- The values of  $I_{OH(dc)}$  and  $I_{OL(dc)}$  are based on the conditions given in Notes 1 and 2. They are used to test device drive current capability to ensure  $V_{IH}$  min plus a noise margin and  $V_{IL}$  max minus a noise margin are delivered to an SSTL\_18 receiver. The actual current values are derived by shifting the desired driver operating point (see Section 3.3) along a 21 ohm load line to define a convenient driver current for measurement.

### 5.3.3 OCD default characteristics

Description	Parameter	Min	Nom	Max	Unit	Notes
Output impedance		12.6	18	23.4	ohms	1,2
Pull-up and pull-down mismatch		0		4	ohms	1,2,3
Output slew rate	Sout	1.5	-	5	V/ns	1,4,5,6,7

#### Notes

- Absolute Specifications ( $0^{\circ}\text{C} \leq T_{CASE} \leq +95^{\circ}\text{C}$ ;  $V_{DD} = +1.8\text{V} \pm 0.1\text{V}$ ,  $V_{DDQ} = +1.8\text{V} \pm 0.1\text{V}$ )
- Impedance measurement condition for output source dc current:  $V_{DDQ} = 1.7\text{V}$ ;  $V_{OUT} = 1420\text{mV}$ ;  $(V_{OUT} - V_{DDQ})/I_{oh}$  must be less than 23.4 ohms for values of  $V_{OUT}$  between  $V_{DDQ}$  and  $V_{DDQ} - 280\text{mV}$ . Impedance measurement condition for output sink dc current:  $V_{DDQ} = 1.7\text{V}$ ;  $V_{OUT} = 280\text{mV}$ ;  $V_{OUT}/I_{ol}$  must be less than 23.4 ohms for values of  $V_{OUT}$  between 0V and 280mV.
- Mismatch is absolute value between pull-up and pull-dn, both are measured at same temperature and voltage.
- Slew rate measured from  $v_{il}(ac)$  to  $v_{ih}(ac)$ .
- The absolute value of the slew rate as measured from DC to DC is equal to or greater than the slew rate as measured from AC to AC. This is guaranteed by design and characterization.
- DRAM output slew rate specification Table.

### 5.4 Default Output V-I characteristics

DDR2 SDRAM output driver characteristics are defined for full strength default operation as selected by the EMRS1 bits A7-A9 = '111'. The above Figures show the driver characteristics graphically, and tables show the same data in tabular format suitable for input into simulation tools.

#### 5.4.1 Full Strength Default Pulldown Driver Characteristics

Voltage (V)	Pulldown Current (mA)			
	Minimum (23.4 Ohms)	Nominal Default Low (18 ohms)	Nominal Default High (18 ohms)	Maximum (12.6 Ohms)
0.2	8.5	11.3	11.8	15.9
0.3	12.1	16.5	16.8	23.8
0.4	14.7	21.2	22.1	31.8
0.5	16.4	25.0	27.6	39.7
0.6	17.8	28.3	32.4	47.7
0.7	18.6	30.9	36.9	55.0
0.8	19.0	33.0	40.9	62.3
0.9	19.3	34.5	44.6	69.4
1.0	19.7	35.5	47.7	75.3
1.1	19.9	36.1	50.4	80.5
1.2	20.0	36.6	52.6	84.6
1.3	20.1	36.9	54.2	87.7
1.4	20.2	37.1	55.9	90.8
1.5	20.3	37.4	57.1	92.9
1.6	20.4	37.6	58.4	94.9
1.7	20.6	37.7	59.6	97.0
1.8		37.9	60.9	99.1
1.9				101.1

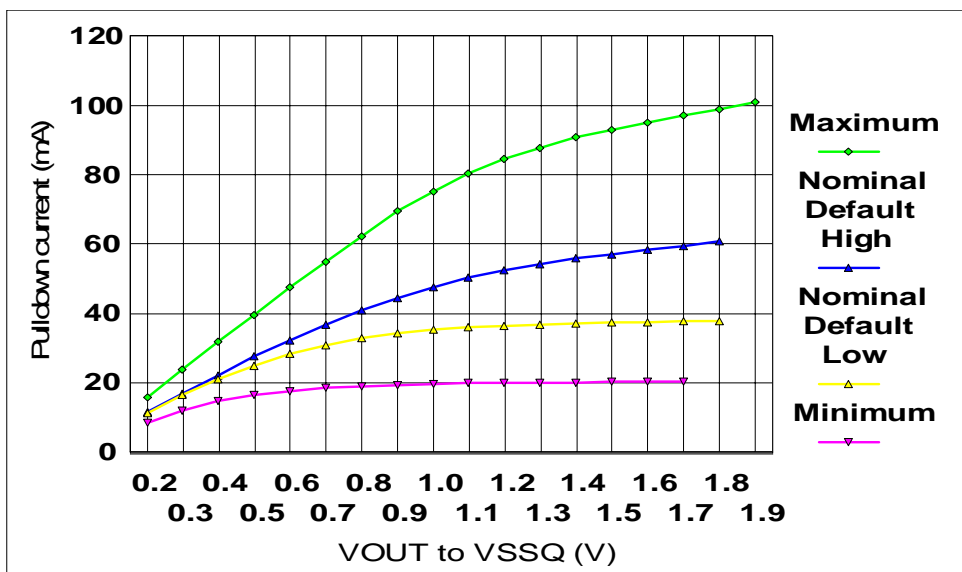

### 5.4.2 Full Strength Default Pullup Driver Characteristics

Voltage (V)	Pullup Current (mA)			
	Minimum (23.4 Ohms)	Nominal Default Low (18 ohms)	Nominal Default High (18 ohms)	Maximum (12.6 Ohms)
0.2	-8.5	-11.1	-11.8	-15.9
0.3	-12.1	-16.0	-17.0	-23.8
0.4	-14.7	-20.3	-22.2	-31.8
0.5	-16.4	-24.0	-27.5	-39.7
0.6	-17.8	-27.2	-32.4	-47.7
0.7	-18.6	-29.8	-36.9	-55.0
0.8	-19.0	-31.9	-40.8	-62.3
0.9	-19.3	-33.4	-44.5	-69.4
1.0	-19.7	-34.6	-47.7	-75.3
1.1	-19.9	-35.5	-50.4	-80.5
1.2	-20.0	-36.2	-52.5	-84.6
1.3	-20.1	-36.8	-54.2	-87.7
1.4	-20.2	-37.2	-55.9	-90.8
1.5	-20.3	-37.7	-57.1	-92.9
1.6	-20.4	-38.0	-58.4	-94.9
1.7	-20.6	-38.4	-59.6	-97.0
1.8		-38.6	-60.8	-99.1
1.9				-101.1

DDR2 Default Pullup Characteristics for Full Strength Output Driver

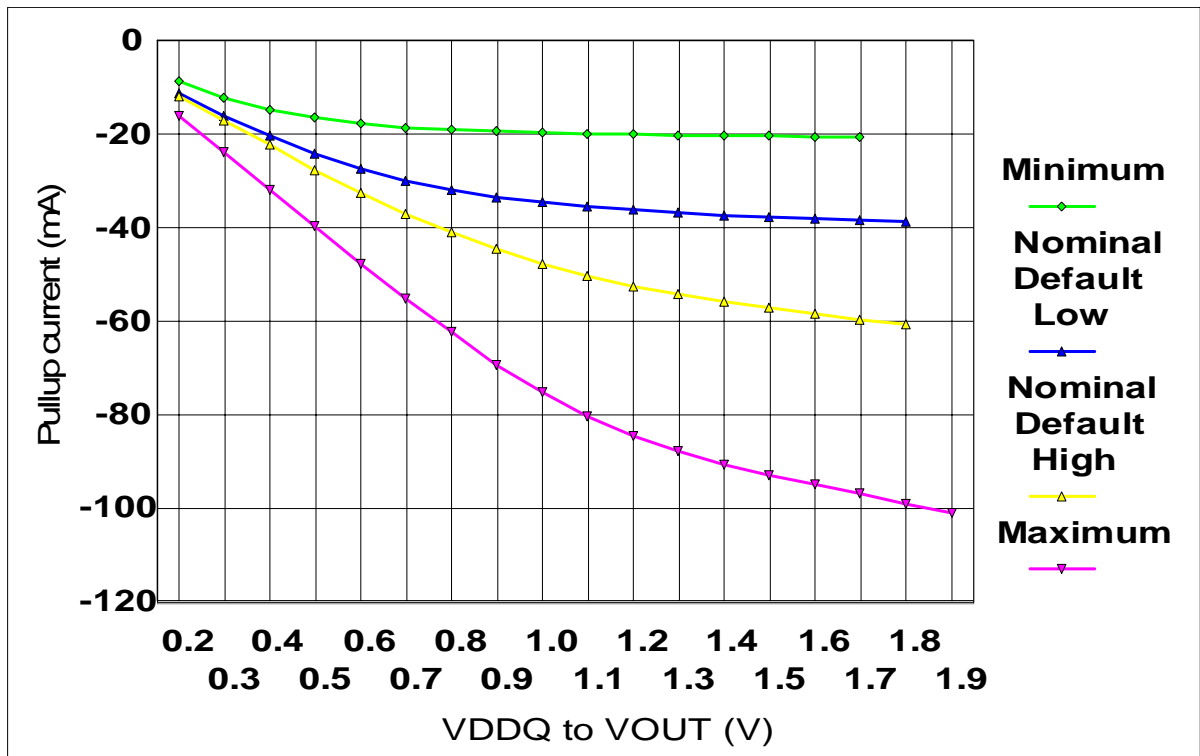

### 5.4.3 Calibrated Output Driver V-I Characteristics

DDR2 SDRAM output driver characteristics are defined for full strength calibrated operation as selected by the procedure in OCD impedance adjustment. The below Tables show the data in tabular format suitable for input into simulation tools. The nominal points represent a device at exactly 18 ohms. The nominal low and nominal high values represent the range that can be achieved with a maximum 1.5 ohm step size with no calibration error at the exact nominal conditions only (i.e. perfect calibration procedure, 1.5 ohm maximum step size guaranteed by specification). Real system calibration error needs to be added to these values. It must be understood that these V-I curves as represented here or in supplier IBIS models need to be adjusted to a wider range as a result of any system calibration error. Since this is a system specific phenomena, it cannot be quantified here. The values in the calibrated tables represent just the DRAM portion of uncertainty while looking at one DQ only. If the calibration procedure is used, it is possible to cause the device to operate outside the bounds of the default device characteristics tables and figures. In such a situation, the timing parameters in the specification cannot be guaranteed. It is solely up to the system application to ensure that the device is calibrated between the minimum and maximum default values at all times. If this can't be guaranteed by the system calibration procedure, re-calibration policy, and uncertainty with DQ to DQ variation, then it is recommended that only the default values be used. The nominal maximum and minimum values represent the change in impedance from nominal low and high as a result of voltage and temperature change from the nominal condition to the maximum and minimum conditions. If calibrated at an extreme condition, the amount of variation could be as much as from the nominal minimum to the nominal maximum or vice versa. The driver characteristics evaluation conditions are:

Nominal 25 °C (T case), VDDQ = 1.8 V, typical process

Nominal Low and Nominal High 25 °C (T case), VDDQ = 1.8 V, any process

Nominal Minimum TBD °C (T case), VDDQ = 1.7 V, any process

Nominal Maximum 0 °C (T case), VDDQ = 1.9 V, any process

### Full Strength Calibrated Pulldown Driver Characteristics

Calibrated Pulldown Current (mA)					
Voltage (V)	Nominal Minimum (21 ohms)	Nominal Low (18.75 ohms)	Nominal (18 ohms)	Nominal High (17.25 ohms)	Nominal Maximum (15 ohms)
0.2	9.5	10.7	11.5	11.8	13.3
0.3	14.3	16.0	16.6	17.4	20.0
0.4	18.7	21.0	21.6	23.0	27.0

### Full Strength Calibrated Pullup Driver Characteristics

Calibrated Pullup Current (mA)					
Voltage (V)	Nominal Minimum (21 ohms)	Nominal Low (18.75 ohms)	Nominal (18 ohms)	Nominal High (17.25 ohms)	Nominal Maximum (15 ohms)
0.2	-9.5	-10.7	-11.4	-11.8	-13.3
0.3	-14.3	-16.0	-16.5	-17.4	-20.0
0.4	-18.7	-21.0	-21.2	-23.0	-27.0

## 5.5 Input/Output Capacitance

Parameter	Symbol	300MHz / 400MHz		Units
		Min	Max	
Input capacitance, CK and $\overline{CK}$	CCK	1.0	2.0	pF
Input capacitance delta, CK and $\overline{CK}$	CDCK	x	0.25	pF
Input capacitance, all other input-only pins	CI	1.0	2.0	pF
Input capacitance delta, all other input-only pins	CDI	x	0.25	pF
Input/output capacitance, DQ, DM, DQS, $\overline{DQS}$	CIO	2.5	3.5	pF
Input/output capacitance delta, DQ, DM, DQS, $\overline{DQS}$	CDIO	x	0.5	pF

## 6. IDD Specifications & Measurement Conditions

### 6.1 IDD Specifications

Symbol		2	22	25	28	Units
IDD0		110	105	100	95	mA
IDD1		120	115	110	105	mA
IDD2P		8	8	8	8	mA
IDD2N		55	53	50	45	mA
IDD3P	F	35	33	30	25	mA
	S	25	25	25	25	mA
IDD3N		70	65	60	55	mA
IDD4W		250	225	200	175	mA
IDD4R		250	225	200	175	mA
IDD5		130	128	125	123	mA
IDD6		8	8	8	8	mA
IDD7		260	240	220	210	mA

## 6.2 IDD Measurement Conditions

Symbol	Conditions	Units	
IDD0	<b>Operating one bank active-precharge current;</b> $t_{CK} = t_{CK}(IDD)$ , $t_{RC} = t_{RC}(IDD)$ , $t_{RAS} = t_{RASmin}(IDD)$ ; CKE is HIGH, $\overline{CS}$ is HIGH between valid commands; Address bus inputs are SWITCHING; Data bus inputs are SWITCHING	mA	
IDD1	<b>Operating one bank active-read-precharge current;</b> $I_{OUT} = 0mA$ ; $BL = 4$ , $CL = CL(IDD)$ , $AL = 0$ ; $t_{CK} = t_{CK}(IDD)$ , $t_{RC} = t_{RC}(IDD)$ , $t_{RAS} = t_{RASmin}(IDD)$ , $t_{RCD} = t_{RCD}(IDD)$ ; CKE is HIGH, $\overline{CS}$ is HIGH between valid commands; Address bus inputs are SWITCHING; Data pattern is same as IDD4W	mA	
IDD2P	<b>Precharge power-down current;</b> All banks idle; $t_{CK} = t_{CK}(IDD)$ ; CKE is LOW; Other control and address bus inputs are STABLE; Data bus inputs are FLOATING	mA	
IDD2N	<b>Precharge standby current;</b> All banks idle; $t_{CK} = t_{CK}(IDD)$ ; CKE is HIGH, $\overline{CS}$ is HIGH; Other control and address bus inputs are SWITCHING; Data bus inputs are SWITCHING	mA	
IDD3P	<b>Active power-down current;</b> All banks open; $t_{CK} = t_{CK}(IDD)$ ; CKE is LOW; Other control and address bus inputs are STABLE; Data bus inputs are FLOATING	Fast PDN Exit MRS(12) = 0	mA
		Slow PDN Exit MRS(12) = 1	mA
IDD3N	<b>Active standby current;</b> All banks open; $t_{CK} = t_{CK}(IDD)$ , $t_{RAS} = t_{RASmax}(IDD)$ , $t_{RP} = t_{RP}(IDD)$ ; CKE is HIGH, $\overline{CS}$ is HIGH between valid commands; Other control and address bus inputs are SWITCHING; Data bus inputs are SWITCHING	mA	
IDD4W	<b>Operating burst write current;</b> All banks open, Continuous burst writes; $BL = 4$ , $CL = CL(IDD)$ , $AL = 0$ ; $t_{CK} = t_{CK}(IDD)$ , $t_{RAS} = t_{RASmax}(IDD)$ , $t_{RP} = t_{RP}(IDD)$ ; CKE is HIGH, $\overline{CS}$ is HIGH between valid commands; Address bus inputs are SWITCHING; Data bus inputs are SWITCHING	mA	
IDD4R	<b>Operating burst read current;</b> All banks open, Continuous burst reads, $I_{OUT} = 0mA$ ; $BL = 4$ , $CL = CL(IDD)$ , $AL = 0$ ; $t_{CK} = t_{CK}(IDD)$ , $t_{RAS} = t_{RASmax}(IDD)$ , $t_{RP} = t_{RP}(IDD)$ ; CKE is HIGH, $\overline{CS}$ is HIGH between valid commands; Address bus inputs are SWITCHING; Data pattern is same as IDD4W	mA	
IDD5B	<b>Burst refresh current;</b> $t_{CK} = t_{CK}(IDD)$ ; Refresh command at every $t_{RFC}(IDD)$ interval; CKE is HIGH, $\overline{CS}$ is HIGH between valid commands; Other control and address bus inputs are SWITCHING; Data bus inputs are SWITCHING	mA	
IDD6	<b>Self refresh current;</b> CK and $\overline{CK}$ at 0V; $CKE \leq 0.2V$ ; Other control and address bus inputs are FLOATING; Data bus inputs are FLOATING	mA	
IDD7	<b>Operating bank interleave read current;</b> All bank interleaving reads, $I_{OUT} = 0mA$ ; $BL = 4$ , $CL = CL(IDD)$ , $AL = t_{RCD}(IDD) - 1 * t_{CK}(IDD)$ ; $t_{CK} = t_{CK}(IDD)$ , $t_{RC} = t_{RC}(IDD)$ , $t_{RRD} = t_{RRD}(IDD)$ , $t_{RCD} = 1 * t_{CK}(IDD)$ ; CKE is HIGH, $\overline{CS}$ is HIGH between valid commands; Address bus inputs are STABLE during DESELECTs; Data pattern is same as IDD4R; - Refer to the following page for detailed timing conditions	mA	

### Note:

- IDD specifications are tested after the device is properly initialized
- Input slew rate is specified by AC Parametric Test Condition
- IDD parameters are specified with ODT disabled.
- Data bus consists of DQ, DM, DQS,  $\overline{DQS}$ , RDQS,  $\overline{RDQS}$ , LDQS,  $\overline{LDQS}$ , UDQS, and  $\overline{UDQS}$ . IDD values must be met with all combinations of EMRS bits 10 and 11.
- Definitions for IDD
  - LOW is defined as  $V_{in} \leq V_{ILAC}(max)$
  - HIGH is defined as  $V_{in} \geq V_{IHAC}(min)$
  - STABLE is defined as inputs stable at a HIGH or LOW level
  - FLOATING is defined as inputs at  $V_{REF} = V_{DDQ}/2$
  - SWITCHING is defined as:
    - inputs changing between HIGH and LOW every other clock cycle (once per two clocks) for address and control signals, and
    - inputs changing between HIGH and LOW every other data transfer (once per clock) for DQ signals not including masks or strobes.

**For purposes of IDD testing, the following parameters are to be utilized**

Parameter	2	22	25	28	Unit
CL(IDD)	7	6	6	5	tCK
tRCD(IDD)	16	15.4	15	16.8	ns
tRC(IDD)	60	61.6	60	61.6	ns
tRRD(IDD)-x16	8	8.8	7.5	8.4	ns
tCK(IDD)	2	2.2	2.5	2.8	ns
tRASmin(IDD)	44	46.2	45	44.8	ns
tRASmax(IDD)	70K	70K	70K	70K	ns
tRP(IDD)	16	15.4	15	16.8	ns
tRFC(IDD)-256Mb	75	75	75	75	ns

#### Detailed IDD7

The detailed timings are shown below for IDD7. Changes will be required if timing parameter changes are made to the specification.

Legend: A = Active; RA = Read with Autoprecharge; D = Deselect

#### **IDD7: Operating Current: All Bank Interleave Read operation**

All banks are being interleaved at minimum tRC(IDD) without violating tRRD(IDD) using a burst length of 4. Control and address bus inputs are STABLE during DESELECTs. IOUT = 0mA

## 7. AC Timing Specifications

### 7.1 Timing Parameters by Speed Grade

Parameter	Symbol	2		22		Unit	Note	
		min	max	min	max			
DQ output access time from CK/ $\overline{\text{CK}}$	tAC	-300	+300	-350	+350	ps		
DQS output access time from CK/ $\overline{\text{CK}}$	tDQSK	-250	+250	-300	+300	ps		
CK high-level width	tCH	0.45	0.55	0.45	0.55	tCK		
CK low-level width	tCL	0.45	0.55	0.45	0.55	tCK		
CK half period	tHP	min (tCL,tCH)	-	min (tCL,tCH)	-	ps	11,12	
Clock cycle time	CL=7	tCK	2	8	-	-	ns	15
	CL=6	tCK	-	-	2.2	8	ns	15
DQ and DM input hold time	tDH	125	-	125	-	ps	6,7,8	
DQ and DM input setup time	tDS	50	-	50	-	ps	6,7,8	
Control & Address input pulse width for each input	tIPW	0.6	-	0.6	-	tCK		
DQ and DM input pulse width for each input	tDIPW	0.35	-	0.35	-	tCK		
Data-out high-impedance time from CK/ $\overline{\text{CK}}$	tHZ	-	tAC max	-	tAC max	ps		
DQS low-impedance time from CK/ $\overline{\text{CK}}$	tLZ(DQS)	tAC min	tAC max	tAC min	tAC max	ps		
DQ low-impedance time from CK/ $\overline{\text{CK}}$	tLZ(DQ)	2*tAC min	tAC max	2*tAC min	tAC max	ps		
DQS-DQ skew for DQS and associated DQ signals	tDQSQ	-	200	-	200	ps	13	
DQ hold skew factor	tQHS	-	300	-	300	ps	12	
DQ/DQS output hold time from DQS	tQH	tHP - tQHS	-	tHP - tQHS	-	ps		
Write command to first DQS latching transition	tDQSS	WL - 0.25	WL + 0.25	WL - 0.25	WL+0.25	tCK		
DQS input high pulse width	tDQSH	0.35	-	0.35	-	tCK		
DQS input low pulse width	tDQSL	0.35	-	0.35	-	tCK		
DQS falling edge to CK setup time	tDSS	0.2	-	0.2	-	tCK		
DQS falling edge hold time from CK	tDSH	0.2	-	0.2	-	tCK		
Mode register set command cycle time	tMRD	2	-	2	-	tCK		
Write postamble	tWPST	0.4	0.6	0.4	0.6	tCK	10	
Write preamble	tWPRE	0.35	-	0.35	-	tCK		
Address and control input hold time	tIH	300	-	350	-	ps	5,7,9	
Address and control input setup time	tIS	300	-	350	-	ps	5,7,9	
Read preamble	tRPRE	0.9	1.1	0.9	1.1	tCK		
Read postamble	tRPST	0.4	0.6	0.4	0.6	tCK		
Active to precharge command	tRAS	45	70K	45	70K	ns	3	
Active to Read or Write (with and without Auto-Precharge) delay	tRCD	16	-	15.4	-	ns		

Parameter	Symbol	2		22		Unit	Note
		min	max	min	max		
Auto-Refresh to Active/Auto-Refresh command period	tRFC	75	-	75	-	ns	
Precharge Command Period	tRP	16	-	15.4	-	ns	
Active to Active/Auto-Refresh command period	tRC	60	-	61.6	-	ns	
Active to active command period	tRRD	8	-	8.8	-	ns	4
CAS to $\overline{\text{CAS}}$ command delay	tCCD	2		2		tCK	
Write recovery time	tWR	14	-	15	-	ns	
Auto precharge write recovery + precharge time	tDAL	WR+tRP	-	WR+tRP	-	tCK	14
Internal write to read command delay	tWTR	7.5	-	7.5	-	ns	
Internal read to precharge command delay	tRTP	7.5	-	7.5	-	ns	3
Exit self refresh to a non-read command	tXSNR	tRFC + 10		tRFC + 10		ns	
Exit self refresh to a read command	tXSRD	200	-	200	-	tCK	
Exit precharge power down to any non-read command	tXP	2	-	2	-	tCK	
Exit active power down to read command	tXARD	2		2		tCK	1
Exit active power down to read command (Slow exit, Lower power)	tXARDS	8 - AL		8 - AL		tCK	1, 2
CKE minimum pulse width (high and low pulse width)	t <sup>CKE</sup>	3		3		tCK	
Average periodic Refresh Interval	tREFI		7.8		7.8	us	
ODT turn-on delay	t <sup>AOND</sup>	2	2	2	2	tCK	
ODT turn-on	t <sup>AON</sup>	tAC(min)	tAC(max)+0.7	tAC(min)	tAC(max)+0.7	ns	16
ODT turn-on(Power-Down mode)	t <sup>AONPD</sup>	tAC(min)+2	2tCK+tAC(max)+1	tAC(min)+2	2tCK+tAC(max)+1	ns	
ODT turn-off delay	t <sup>AOFD</sup>	2.5	2.5	2.5	2.5	tCK	
ODT turn-off	t <sup>AOF</sup>	tAC(min)	tAC(max)+ 0.6	tAC(min)	tAC(max)+0.6	ns	17
ODT turn-off (Power-Down mode)	t <sup>AOFPD</sup>	tAC(min)+2	4.5tCK+tAC(max)+1	tAC(min)+2	4.5tCK+tAC(max)+1	ns	
ODT to power down entry latency	tANPD	3		3		tCK	
ODT power down exit latency	tAXPD	8		8		tCK	
OCD drive mode output delay	tOIT	0	12	0	12	ns	
Minimum time clocks remains ON after CKE asynchronously drops LOW	tDelay	tIS+tCK+tIH		tIS+tCK+tIH		ns	15

Parameter	Symbol	25		28		Unit	Note	
		min	max	min	max			
DQ output access time from CK/ $\overline{\text{CK}}$	tAC	-450	+450	-450	+450	ps		
DQS output access time from CK/ $\overline{\text{CK}}$	tDQSCK	-400	+400	-400	+400	ps		
CK high-level width	tCH	0.45	0.55	0.45	0.55	tCK		
CK low-level width	tCL	0.45	0.55	0.45	0.55	tCK		
CK half period	tHP	min (tCL,tCH)	-	min (tCL,tCH)	-	ps	11,12	
Clock cycle time	CL=6	tCK	2.5	8	-	ns	15	
	CL=5	tCK	-	-	2.8	8	ns	15
	CL=4	tCK	-	-	-	-	ns	15
DQ and DM input hold time	tDH	175	-	175	-	ps	6,7,8	
DQ and DM input setup time	tDS	50	-	50	-	ps	6,7,8	
Control & Address input pulse width for each input	tIPW	0.6	-	0.6	-	tCK		
DQ and DM input pulse width for each input	tDIPW	0.35	-	0.35	-	tCK		
Data-out high-impedance time from CK/ $\overline{\text{CK}}$	tHZ	-	tAC max	-	tAC max	ps		
DQS low-impedance time from CK/ $\overline{\text{CK}}$	tLZ(DQS)	tAC min	tAC max	tAC min	tAC max	ps		
DQ low-impedance time from CK/ $\overline{\text{CK}}$	tLZ(DQ)	2*tAC min	tAC max	2*tAC min	tAC max	ps		
DQS-DQ skew for DQS and associated DQ signals	tDQSQ	-	200	-	250	ps	13	
DQ hold skew factor	tQHS	-	350	-	350	ps	12	
DQ/DQS output hold time from DQS	tQH	tHP - tQHS	-	tHP - tQHS	-	ps		
Write command to first DQS latching transition	tDQSS	WL - 0.25	WL + 0.25	WL - 0.25	WL + 0.25	tCK		
DQS input high pulse width	tDQSH	0.35	-	0.35	-	tCK		
DQS input low pulse width	tDQSL	0.35	-	0.35	-	tCK		
DQS falling edge to CK setup time	tDSS	0.2	-	0.2	-	tCK		
DQS falling edge hold time from CK	tDSH	0.2	-	0.2	-	tCK		
Mode register set command cycle time	tMRD	2	-	2	-	tCK		
Write postamble	tWPST	0.4	0.6	0.4	0.6	tCK	10	
Write preamble	tWPRE	0.35	-	0.35	-	tCK		
Address and control input hold time	tIH	400	-	400	-	ps	5,7,9	
Address and control input setup time	tIS	400	-	400	-	ps	5,7,9	
Read preamble	tRPRE	0.9	1.1	0.9	1.1	tCK		
Read postamble	tRPST	0.4	0.6	0.4	0.6	tCK		
Active to precharge command	tRAS	45	70K	45	70K	ns	3	

Parameter	Symbol	25		28		Unit	Note
		min	max	min	max		
Active to Read or Write (with and without Auto-Precharge) delay	tRCD	15	-	16.8	-	ns	
Auto-Refresh to Active/Auto-Refresh command period	tRFC	75		75	-	ns	
Precharge Command Period	tRP	15		16.8	-	ns	
Active to Active/Auto-Refresh command period	tRC	60		61.6	-	ns	
Active to active command period	tRRD	8		8.4	-	ns	4
CAS to $\overline{\text{CAS}}$ command delay	tCCD	3		2		tCK	
Write recovery time	tWR	15		15	-	ns	
Auto precharge write recovery + precharge time	tDAL	WR+tRP	-	WR+tRP	-	tCK	14
Internal write to read command delay	tWTR	3	-	3	-	tCK	
Internal read to precharge command delay	tRTP	3	-	3	-	tCK	3
Exit self refresh to a non-read command	tXSNR	tRFC + 10		tRFC + 10		ns	
Exit self refresh to a read command	tXSRD	200	-	200	-	tCK	
Exit precharge power down to any non-read command	tXP	2	-	2	-	tCK	
Exit active power down to read command	tXARD	2		2		tCK	1
Exit active power down to read command (Slow exit, Lower power)	tXARDS	8 - AL		7 - AL		tCK	1, 2
CKE minimum pulse width (high and low pulse width)	t <sub>CKE</sub>	3		3		tCK	
Average periodic Refresh Interval	tREFI		7.8		7.8	us	
ODT turn-on delay	t <sub>AOND</sub>	2	2	2	2	tCK	
ODT turn-on	t <sub>AON</sub>	tAC(min)	tAC(max)+0.7	tAC(min)	tAC(max)+0.7	ns	16
ODT turn-on(Power-Down mode)	t <sub>AONPD</sub>	tAC(min)+2	2tCK+tAC(max)+1	tAC(min)+2	2tCK+tAC(max)+1	ns	
ODT turn-off delay	t <sub>AOFD</sub>	2.5	2.5	2.5	2.5	tCK	
ODT turn-off	t <sub>AOF</sub>	tAC(min)	tAC(max)+ 0.6	tAC(min)	tAC(max)+ 0.6	ns	17
ODT turn-off (Power-Down mode)	t <sub>AOFPD</sub>	tAC(min)+2	3.5tCK+tAC(max)+1	tAC(min)+2	3.5tCK+tAC(max)+1	ns	
ODT to power down entry latency	tANPD	3		3		tCK	
ODT power down exit latency	tAXPD	8		8		tCK	
OCD drive mode output delay	tOIT	0	12	0	12	ns	
Minimum time clocks remains ON after CKE asynchronously drops LOW	tDelay	tIS+tCK+tIH		tIS+tCK+tIH		ns	15

## 7.2 General notes, which may apply for all AC parameters

### 1. Slew Rate Measurement Levels

- a. Output slew rate for falling and rising edges is measured between  $V_{TT} - 250\text{ mV}$  and  $V_{TT} + 250\text{ mV}$  for single ended signals. For differential signals (e.g.  $\overline{DQS} - DQS$ ) output slew rate is measured between  $\overline{DQS} - DQS = -500\text{ mV}$  and  $\overline{DQS} - DQS = +500\text{ mV}$ . Output slew rate is guaranteed by design, but is not necessarily tested on each device.
- b. Input slew rate for single ended signals is measured from dc-level to ac-level: from  $V_{REF} - 125\text{ mV}$  to  $V_{REF} + 250\text{ mV}$  for rising edges and from  $V_{REF} + 125\text{ mV}$  and  $V_{REF} - 250\text{ mV}$  for falling edges. For differential signals (e.g.  $\overline{CK} - CK$ ) slew rate for rising edges is measured from  $\overline{CK} - CK = -250\text{ mV}$  to  $\overline{CK} - CK = +500\text{ mV}$  (250mV to -500 mV for falling edges).
- c. VID is the magnitude of the difference between the input voltage on CK and the input voltage on  $\overline{CK}$ , or between DQS and  $\overline{DQS}$  for differential strobe.

### 2. DDR2 SDRAM AC timing reference load

The following figure represents the timing reference load used in defining the relevant timing parameters of the part. It is not intended to be either a precise representation of the typical system environment nor a depiction of the actual load presented by a production tester. System designers will use IBIS or other simulation tools to correlate the timing reference load to a system environment. Manufacturers will correlate to their production test conditions (generally a coaxial transmission line terminated at the tester electronics).

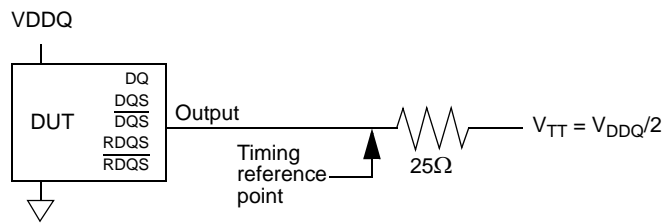

AC Timing Reference Load

The output timing reference voltage level for single ended signals is the crosspoint with  $V_{TT}$ . The output timing reference voltage level for differential signals is the crosspoint of the true (e.g. DQS) and the complement (e.g.  $\overline{DQS}$ ) signal.

### 3. DDR2 SDRAM output slew rate test load

Output slew rate is characterized under the test conditions as shown below.

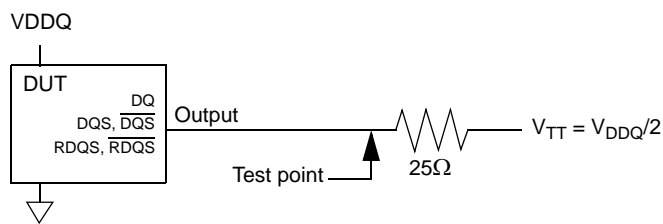

Slew Rate Test Load

### 4. Differential data strobe

DDR2 SDRAM pin timings are specified for either single ended mode or differential mode depending on the setting of the EMRS "Enable DQS" mode bit; timing advantages of differential mode are realized in system design. The method by which the DDR2 SDRAM pin timings are measured is mode dependent. In single ended mode, timing relationships are measured relative to the rising or falling edges of DQS crossing at

VREF. In differential mode, these timing relationships are measured relative to the crosspoint of DQS and its complement,  $\overline{DQS}$ . This distinction in timing methods is guaranteed by design and characterization. Note that when differential data strobe mode is disabled via the EMRS, the complementary pin,  $\overline{DQS}$ , must be tied externally to VSS through a 20 ohm to 10 K ohm resistor to insure proper operation.

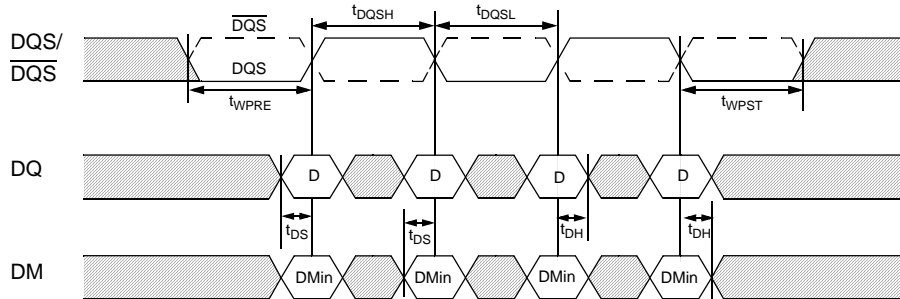

Figure -- Data input (write) timing

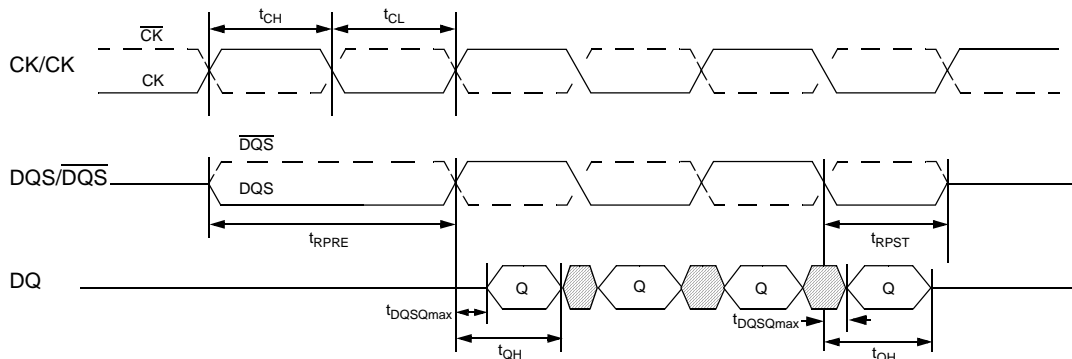

Figure -- Data output (read) timing

5. AC timings are for linear signal transitions. See System Derating for other signal transitions.
6. These parameters guarantee device behavior, but they are not necessarily tested on each device. They may be guaranteed by device design or tester correlation.
7. All voltages referenced to VSS.
8. Tests for AC timing,  $I_{DD}$ , and electrical (AC and DC) characteristics, may be conducted at nominal reference/supply voltage levels, but the related specifications and device operation are guaranteed for the full voltage range specified.

### 7.3 Specific Notes for dedicated AC parameters

1. User can choose which active power down exit timing to use via MRS(bit 12). tXARD is expected to be used for fast active power down exit timing. tXARDS is expected to be used for slow active power down exit timing where a lower power value is defined by each vendor data sheet.

2. AL = Additive Latency

3. This is a minimum requirement. Minimum read to precharge timing is  $AL + BL/2$  providing the tRTP and tRAS(min) have been satisfied.

4. A minimum of two clocks ( $2 * tCK$ ) is required irrespective of operating frequency

5. Timings are guaranteed with command/address input slew rate of 1.0 V/ns. See System Derating for other slew rate values.

6. Timings are guaranteed with data, mask, and (DQS/RDQS in singled ended mode) input slew rate of 1.0 V/ns. See System Derating for other slew rate values.

7. Timings are guaranteed with  $CK/\overline{CK}$  differential slew rate of 2.0 V/ns. Timings are guaranteed for DQS signals with a differential slew rate of 2.0 V/ns in differential strobe mode and a slew rate of 1V/ns in single ended mode. See System Derating for other slew rate values.

8. tDS and tDH (data setup and hold) derating

tbd

9. tIS and tIH (input setup and hold) derating

tbd

10. The maximum limit for this parameter is not a device limit. The device will operate with a greater value for this parameter, but system performance (bus turnaround) will degrade accordingly.

11. MIN ( t CL, t CH) refers to the smaller of the actual clock low time and the actual clock high time as provided to the device (i.e. this value can be greater than the minimum specification limits for t CL and t CH). For example, t CL and t CH are = 50% of the period, less the half period jitter ( t JIT(HP)) of the clock source, and less the half period jitter due to crosstalk ( t JIT(crosstalk)) into the clock traces.

12. t QH = t HP – t QHS, where:

tHP = minimum half clock period for any given cycle and is defined by clock high or clock low ( tCH, tCL).

tQHS accounts for:

- 1) The pulse duration distortion of on-chip clock circuits; and
- 2) The worst case push-out of DQS on one transition followed by the worst case pull-in of DQ on the next transition, both of which are, separately, due to data pin skew and output pattern effects, and p-channel to n-channel variation of the output drivers.

13. tDQSQ: Consists of data pin skew and output pattern effects, and p-channel to n-channel variation of the output drivers for any given cycle.

14. t DAL = (nWR) + ( tRP/tCK):

For each of the terms above, if not already an integer, round to the next highest integer. tCK refers to the application clock period. nWR refers to the t WR parameter stored in the MRS.

15. The clock frequency is allowed to change during self-refresh mode or precharge power-down mode. In case of clock frequency change during precharge power-down, a specific procedure is required as described in section 2.9.

16. ODT turn on time min is when the device leaves high impedance and ODT resistance begins to turn on.  
ODT turn on time max is when the ODT resistance is fully on. Both are measured from tAOND.

17. ODT turn off time min is when the device starts to turn off ODT resistance.

ODT turn off time max is when the bus is in high impedance. Both are measured from tAOFD.

### 8 Package Dimension(x16)

#### 84Ball Fine Pitch Ball Grid Array Outline

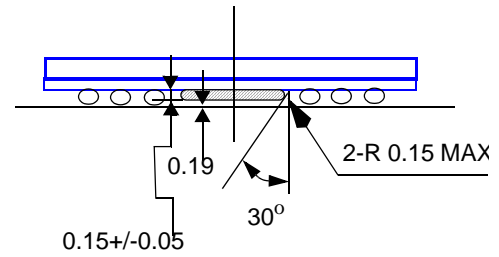
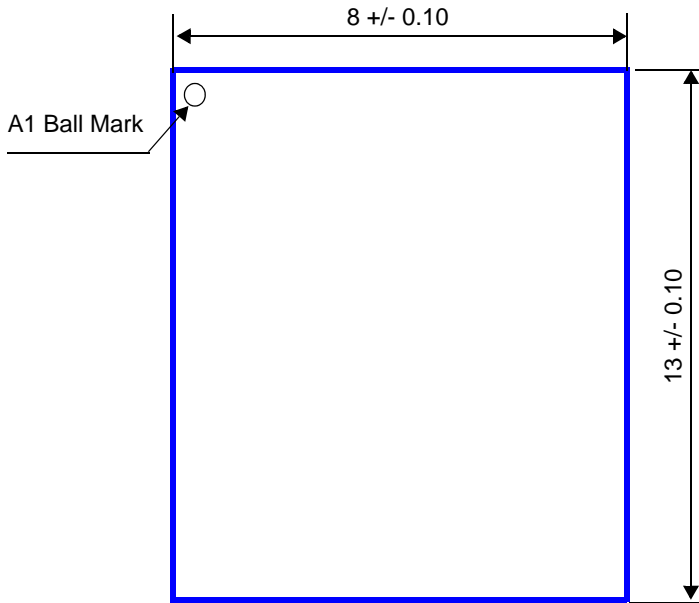

<Top View>

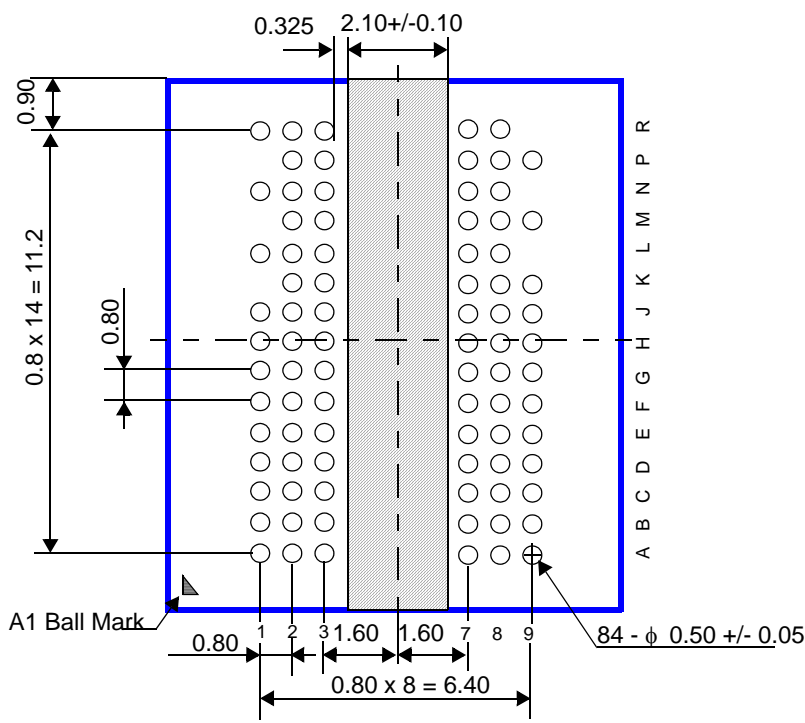

<Bottom View>

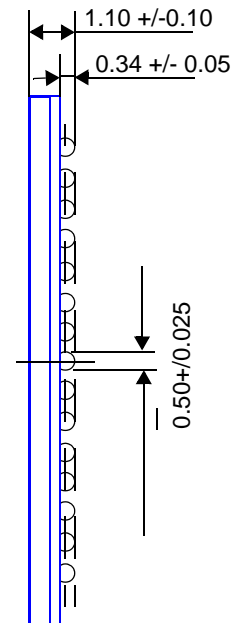

Note: All dimension units are Millimeters.